

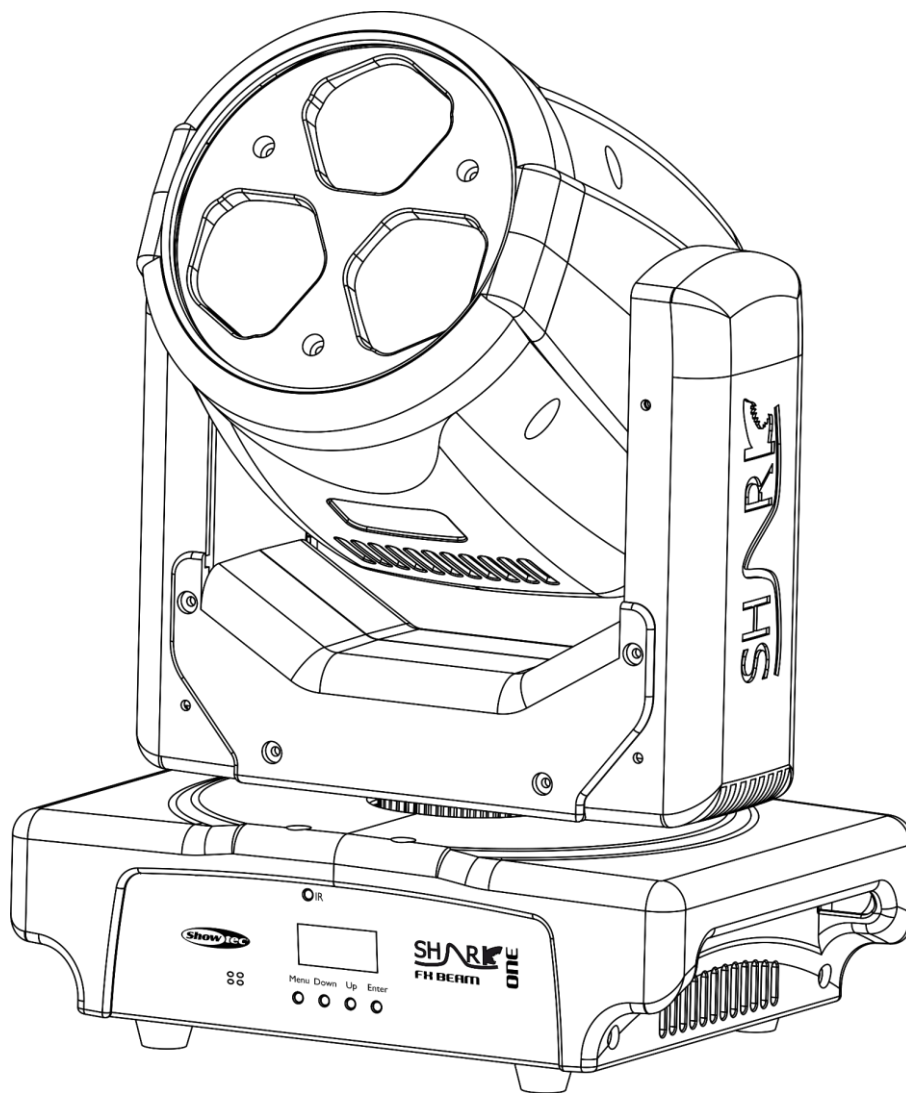

MANUAL



ENGLISH

Shark Beam FX One

V1

Ordercode: 45024

Table of contents

Warning	2
Safety Instructions	2
Operating Determinations	4
Rigging	4
Connection with the mains.....	5
Return Procedure	6
Claims.....	6
Description of the device	7
Frontside.....	7
Backside	8
Installation	8
Set Up and Operation	8
Control Modes.....	9
One Shark (Auto show, Built-in programs and Sound-controlled)	9
Multiple Sharks (Master/Slave control)	9
Multiple Sharks (DMX Control)	10
Fixture Linking.....	11
Data Cabling.....	11
Control Panel.....	12
Control Mode	12
DMX Addressing.....	12
Menu Overview.....	13
Main Menu Options.....	14
1. DMX Address	14
2. DMX Channel.....	14
3. Running Mode.....	14
4. Programs	15
5. Settings.....	15
5.1. Calibration	16
6. System Info	17
Remote Control.....	18
DMX Channels.....	19
8 channels.....	19
16 channels.....	20
Maintenance	22
Replacing a Fuse	22
Troubleshooting	22
No Light	22
No Response to DMX.....	22
Product Specifications	24
Dimensions	25

Warning



**For your own safety, please read this user manual carefully
before your initial start-up!**



Unpacking Instructions

Immediately upon receiving this product, carefully unpack the carton and check the contents to ensure that all parts are present, and have been received in good condition. Notify the dealer immediately and retain packing material for inspection if any parts appear damaged from shipping or the carton itself shows signs of mishandling. Save the carton and all packing materials. In the event that a fixture must be returned to the factory, it is important that the fixture be returned in the original factory box and packing.

Your shipment includes:

- Showtec Shark Beam FX One
- IEC power cable (1,5 m)
- 1 x remote control
- 1 x mounting bracket
- 1 x safety eye
- User manual

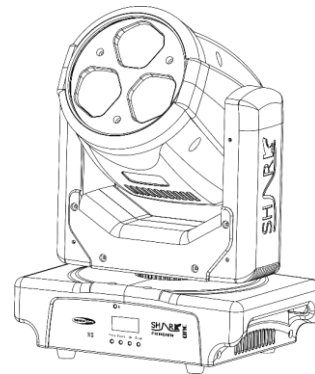

LED Expected Lifespan

LEDs gradually decline in brightness over time. HEAT is the dominant factor that leads to the acceleration of this decline. Packaged in clusters, LEDs exhibit higher operating temperatures than in ideal or singular optimum conditions. For this reason, when all color LEDs are used at their fullest intensity, life of the LEDs is significantly reduced. If improving the lifespan is of higher priority, place care in providing for lower operational temperatures. This may include climatic-environmental and the reduction of overall projection intensity.



CAUTION!

**Keep this device away from rain and moisture!
Unplug mains lead before opening the housing!**



Safety Instructions

Every person involved with the installation, operation and maintenance of this device has to:

- be qualified
- follow the instructions of this manual



**CAUTION! Be careful with your operations.
With a dangerous voltage you can suffer
a dangerous electric shock when touching the wires!**



Before the initial start-up, please make sure that there is no damage caused by transportation. Should there be any, consult your dealer and do not use the device.

To maintain perfect condition and to ensure a safe operation, it is absolutely necessary for the user to follow the safety instructions and warning notes contained in this manual.

Please consider that damages caused by manual modifications to the device are not subject to warranty.

This device contains no user-serviceable parts. Refer servicing to qualified technicians only.

IMPORTANT:

The manufacturer will not accept liability for any resulting damages caused by the non-observance of this manual or any unauthorized modification to the device.

- Never let the power cord come into contact with other cables! Handle the power cord and all connections with the mains with particular caution!
- Never remove warning or informative labels from the unit.
- Never use anything to cover the ground contact.
- Never lift the fixture holding it by the projector-head, as the mechanics may be damaged. Always hold the fixture by the transport handles.
- Never place any material over the lens.
- Never look directly into the light source.
- Never leave any cables lying around.
- Do not insert objects into air vents.
- Do not connect this device to a dimmer pack.
- Do not switch the device on and off in short intervals, as this will reduce the device's life.
- Do not touch the device's housing bare-handed during its operation (housing becomes very hot). Allow the fixture to cool for at least 5 minutes before handling.
- Do not shake the device. Avoid brute force when installing or operating the device.
- Only use the device indoors, avoid contact with water or other liquids.
- Only operate the fixture after having checked if the housing is firmly closed and all screws are tightly fastened.
- Only operate the device after having familiarized with its functions.
- Avoid flames and do not put close to flammable liquids or gases.
- Always keep the case closed while operating.
- Always allow a free air space of at least 50 cm around the unit for ventilation.
- Always disconnect power from the mains, when device is not used or before cleaning! Only handle the power cord holding it by the plug. Never pull out the plug by tugging the power cord.
- Make sure that the device is not exposed to extreme heat, moisture or dust.
- Make sure that the available voltage is not higher than stated on the rear panel.
- Make sure that the power cord is never crimped or damaged. Check the device and the power cord from time to time.
- If the lens is obviously damaged, it has to be replaced.
- If device was dropped or struck, disconnect mains power supply immediately. Have a qualified engineer inspect for safety before operating.
- If the device has been exposed to drastic temperature fluctuation (e.g. after transportation), do not switch it on immediately. The arising condensation water might damage your device. Leave the device switched off until it has reached room temperature.
- If your Showtec device fails to work properly, discontinue the use immediately. Pack the unit securely (preferably in the original packing material), and return it to your Showtec dealer for service.
- For adult use only. The fixture must be installed beyond the reach of children. Never leave the unit running unattended.
- Never attempt to bypass the thermostatic switch or fuses.
- For replacement use fuses of same type and rating only.
- The user is responsible for correct positioning and operating of the Shark. The manufacturer will not accept liability for damages caused by the misuse or incorrect installation of this device.
- This device falls under protection class I. Therefore it is essential to connect the yellow/green conductor to earth.
- Repairs, servicing and electric connection must be carried out by a qualified technician.
- WARRANTY: Till one year after date of purchase.



CAUTION! Eyedamages!!!
Avoid looking directly into the lightsource!!!
(meant especially for epileptics)!!!



Operating Determinations

- This device is not designed for permanent operation. Consistent operation breaks will ensure that the device will serve you for a long time without defects.
- The minimum distance between light output and the illuminated surface must be bigger than 1 meter.
- To eliminate wear and improve lifespan, during periods of non-use, completely disconnect from power via breaker or by unplugging.
- The maximum ambient temperature $t_a = 40^\circ\text{C}$ must never be exceeded.
- The relative humidity must not exceed 50 % with an ambient temperature of 40°C .
- If this device is operated in any other way than the one described in this manual, the product may suffer damages and the warranty becomes void.
- Any other operation may lead to dangers like short-circuit, burns, electric shock, crash, etc.

You endanger your own safety and the safety of others!

Rigging

Please follow the European and national guidelines concerning rigging, trussing and all other safety issues.

Do not attempt the installation yourself !

Always let the installation be carried out by an authorized dealer !

Procedure:

- If the Shark is lowered from the ceiling or high joists, professional trussing systems have to be used.
- Use a clamp to mount the Shark, with the mounting bracket, to the trussing system.
- The Shark must never be fixed swinging freely in the room.
- The installation must always be secured with a safety attachment, e.g. an appropriate safety net or safety cable.
- When rigging, derigging or servicing the Shark, always make sure, that the area below the installation site is secured and that there are not any unauthorized people around.

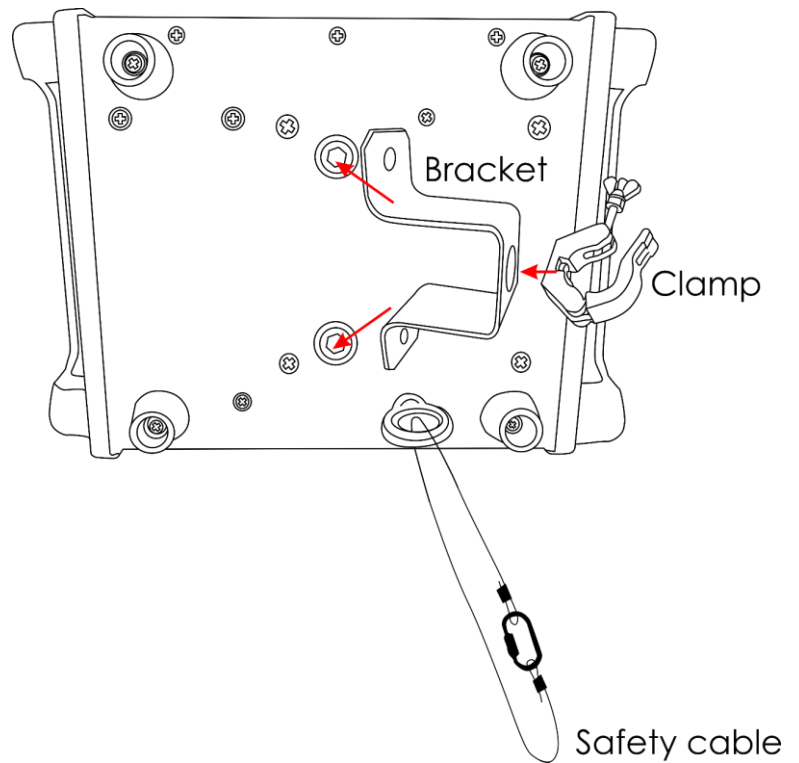
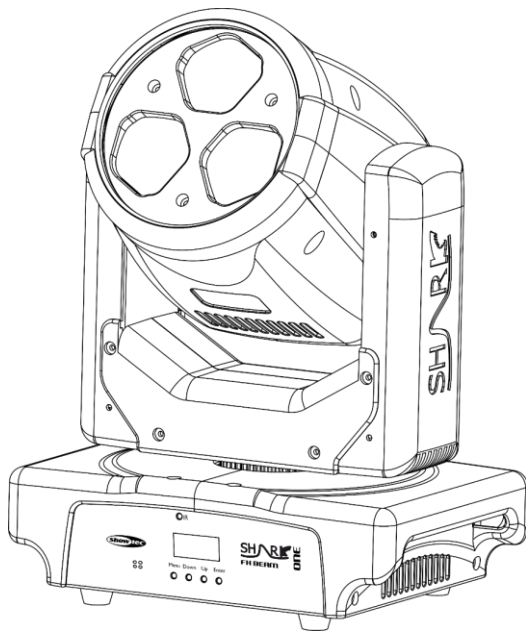

The Shark can be placed on a flat stage floor or mounted to any kind of truss with a clamp.

Improper installation can cause serious injuries and/or damage of property!

Connection with the mains

Connect the device to the mains with the power-plug.

Always check if the right color cable is connected to the right place.

International	EU Cable	UK Cable	US Cable	Pin
L	BROWN	RED	YELLOW/COPPER	PHASE
N	BLUE	BLACK	SILVER	NEUTRAL
⊕	YELLOW/GREEN	GREEN	GREEN	PROTECTIVE GROUND

Make sure that the device is always properly connected to the earth!

Improper installation can cause serious injuries and/or damage of property!



Return Procedure

Returned merchandise must be sent prepaid and in the original packing, call tags will not be issued. Package must be clearly labeled with a Return Authorization Number (RMA number). Products returned without an RMA number will be refused. Highlite will not accept the returned goods or any responsibility. Call Highlite 0031-455667723 or mail offersales@highlite.nl and request an RMA prior to shipping the fixture. Be prepared to provide the model number, serial number and a brief description of the cause for the return. Be sure to properly pack fixture, any shipping damage resulting from inadequate packaging is the customer's responsibility. Highlite reserves the right to use its own discretion to repair or replace product(s). As a suggestion, proper UPS packing or double-boxing is always a safe method to use.

Note: If you are given an RMA number, please include the following information on a piece of paper inside the box:

- 01) Your name
- 02) Your address
- 03) Your phone number
- 04) A brief description of the symptoms

Claims

The client has the obligation to check the delivered goods immediately upon delivery for any shortcomings and/or visible defects, or perform this check after our announcement that the goods are at their disposal. Damage incurred in shipping is the responsibility of the shipper; therefore the damage must be reported to the carrier upon receipt of merchandise.

It is the customer's responsibility to report and submit claims with the shipper in the event that a fixture is damaged due to shipping. Transportation damage has to be reported to us within one day after receipt of the delivery.

Any return shipment has to be made post-paid at all times. Return shipments must be accompanied with a letter defining the reason for return shipment. Non-prepaid return shipments will be refused, unless agreed otherwise in writing.

Complaints against us must be prepared in writing or sent by fax within 10 working days after receipt of the invoice. After this period complaints will not be handled anymore.

Complaints will only then be considered if the client has so far complied with all parts of the agreement, regardless of the agreement from which the obligation is resulting.

Description of the device

Features

The Showtec Shark Beam FX One is a lighting fixture with high output and great effects.

- Input voltage: 100-240V AC, 50/60Hz
- Power consumption: 135W
- Light source: 3 x 40W RGBW 4-in-1 LED
- Lux @2m: 48300 (4°)
- Control protocol: DMX-512
- DMX channels: 8, 16 channels
- Control modes: Auto, Built-in programs, Sound-controlled, Master/Slave, DMX-512
- Dimmer: 0-100%
- Strobe: 0-20Hz
- Pan range: 540°
- Tilt range: 270°
- Pan/Tilt resolution: 16bit
- Zoom: Motorized
- Lens rotation: Continuous
- Beam angle: 4-60°
- Onboard: OLED display for easy setup
- Housing: Metal & flame retardant plastic
- Connections: 3-pin XLR connectors IN/OUT & IEC power IN/OUT
- Cooling: Cooling fan
- Color: Black
- Fuse: F2AL/250V
- Dimensions: 255 x 175 x 355 mm (LxWxH)
- Weight: 5,8 kg

Frontside

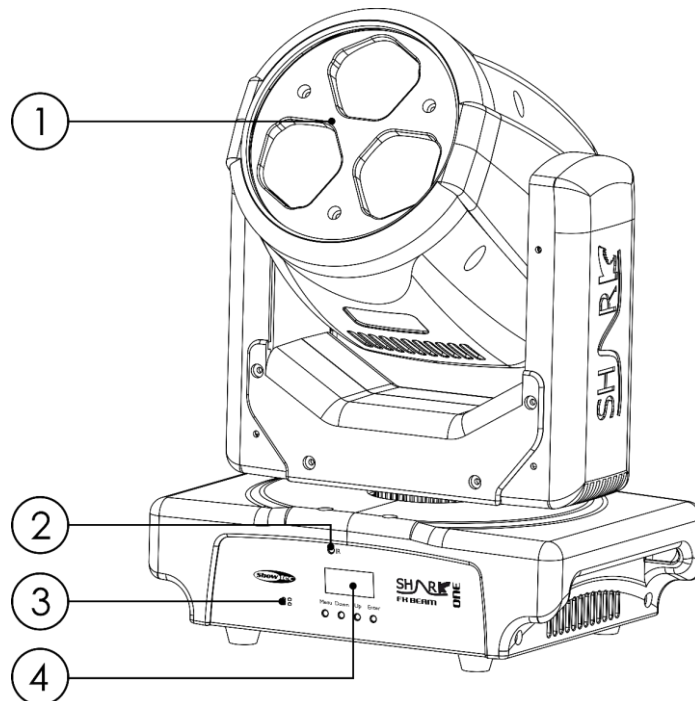

Fig. 01

- 01) 3 x 40W RGBW 4-in-1 LED
- 02) IR receiver
- 03) Built-in microphone
- 04) OLED display + control buttons

Backside

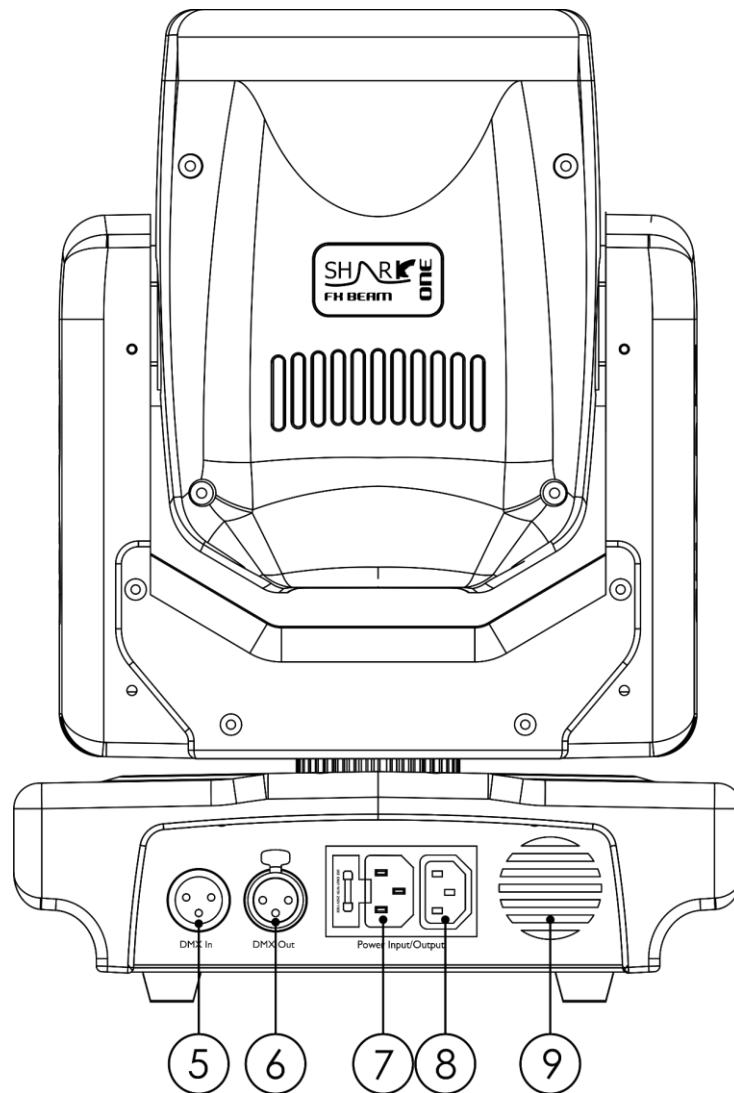

Fig. 02

- 05) 3-pin DMX signal connector IN
- 06) 3-pin DMX signal connector OUT
- 07) 100-240V IEC power connector IN + Fuse F2AL/250V
- 08) 100-240V IEC power connector OUT
- 09) Cooling fan

Installation

Remove all packing materials from the Shark Beam FX One. Check if all foam and plastic padding is removed. Connect all cables.

Do not supply power before the whole system is set up and connected properly.
Always disconnect from electric mains power supply before cleaning or servicing.
Damages caused by non-observance are not subject to warranty.

Set Up and Operation

Follow the directions below, as they pertain to your preferred operation mode.

Before plugging the unit in, always make sure that the power supply matches the product specification voltage. Do not attempt to operate a 120V specification product on 230V power, or vice versa. Connect the device to the main power supply.

Control Modes

There are 5 modes:

- Auto show
- Built-in programs
- Sound-controlled
- Master/Slave
- DMX-512 (8CH, 16CH)

One Shark (Auto show, Built-in programs and Sound-controlled)

- 01) Fasten the effect light to a firm trussing. Leave at least 0,5 meter on all sides for air circulation.
- 02) Plug the end of the electric mains power cord into a proper electric power supply socket.
- 03) When the Shark is not connected with a DMX cable, it functions as a stand-alone device.
- 04) Turn on the music. If the device is set to sound-control, then the Shark will react to the beat of the music.
- 05) Please see pages 14-15 for more information about the Auto show, Built-in programs and Sound-controlled mode.

Multiple Sharks (Master/Slave control)

- 01) Fasten the effect light onto firm trussing. Leave at least 0,5 meter on all sides for air circulation.
- 02) Use a 3-pin XLR cable to connect the Shark.

The pins:



- 01) Earth
- 02) Signal -
- 03) Signal +

- 03) Link the units as shown in fig. 03. Connect the first unit's DMX "out" socket with the second unit's "in" socket, using a DMX signal cable. Repeat this process to link the second, third, and fourth units. You can use the same functions on the master device as described on pages 14-15 (Auto show, Built-in programs or Sound-controlled mode). This means that you can set your desired operation mode on the master device and all slave devices will react the same as the master device.

Multiple Sharks (Master/Slave control)

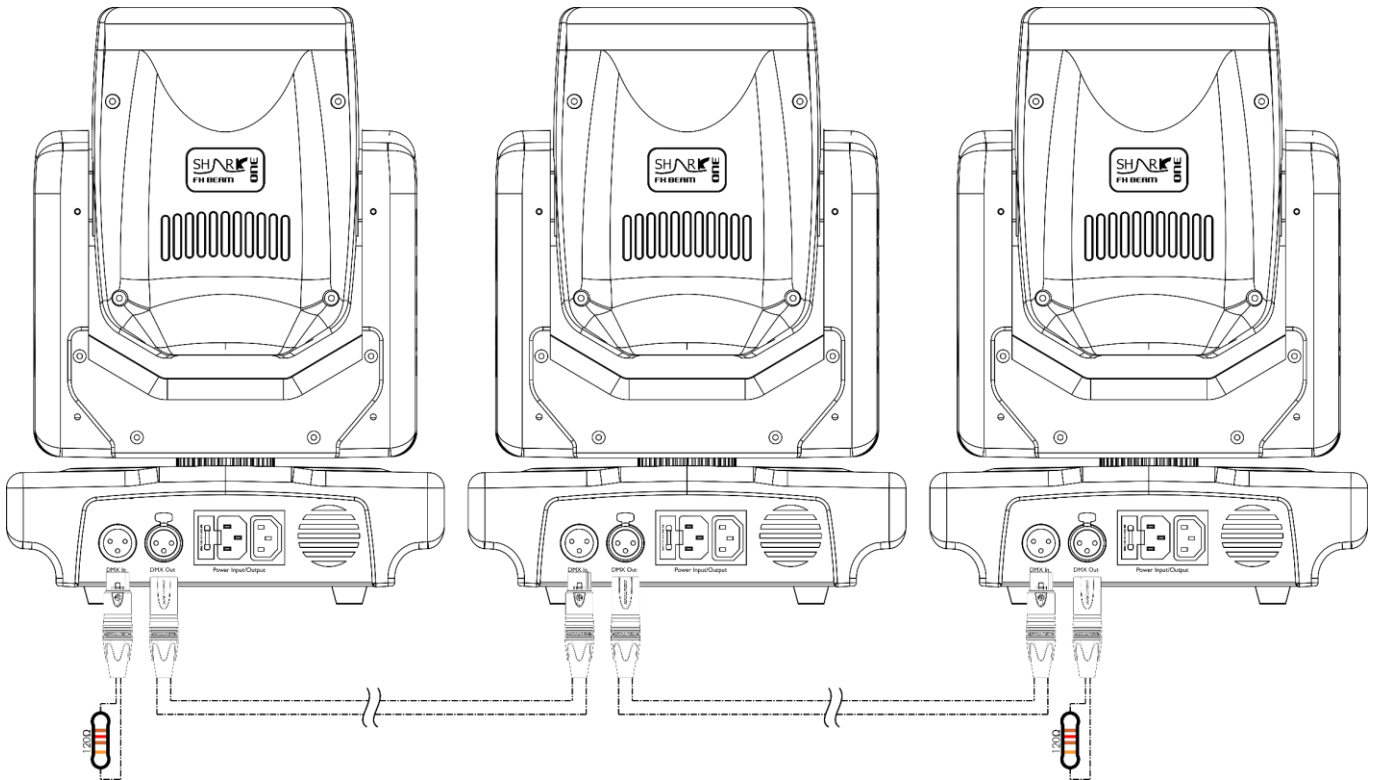
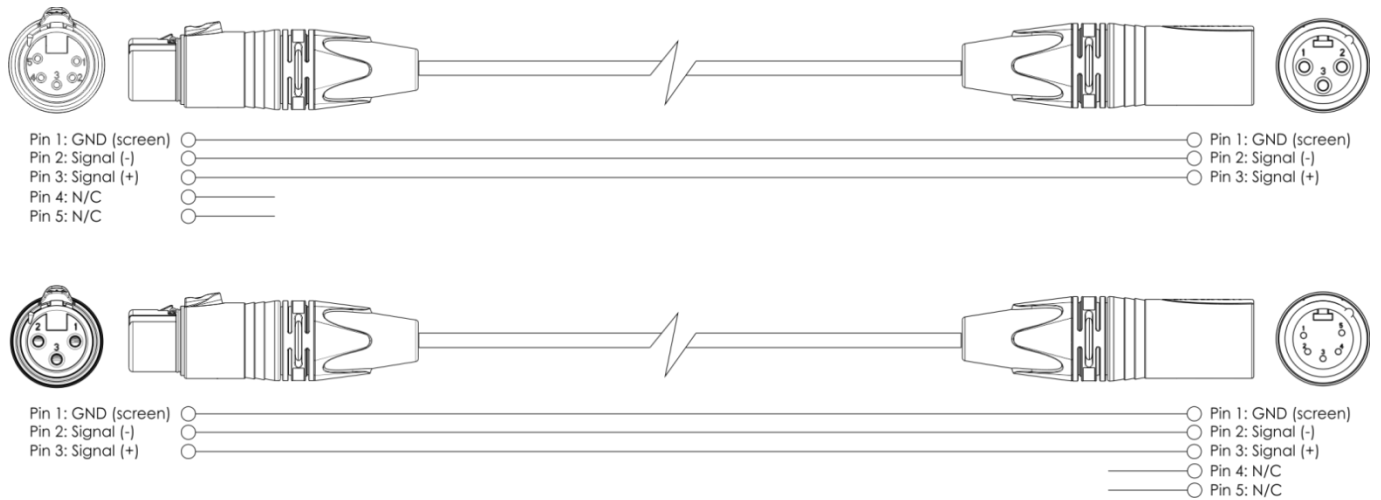

Fig. 03

Multiple Sharks (DMX Control)

- 01) Fasten the effect light to a firm trussing. Leave at least 0,5 meter on all sides for air circulation.
- 02) Always use a safety cable (ordercode 70140 / 70141).
- 03) Use a 3-pin XLR cable to connect the Sharks and other devices.



- 04) Link the units as shown in fig. 04. Connect the first unit's DMX "out" socket with the second unit's "in" socket, using a DMX-signal cable. Repeat this process to link the second, third, and fourth units.
- 05) Supply electric power: Plug electric mains power cords into each unit's IEC socket, then plug the other end of the mains power cord into proper electric power supply sockets, starting with the first unit. Do not supply power before the whole system is set up and connected properly.

Multiple Sharks DMX Set Up

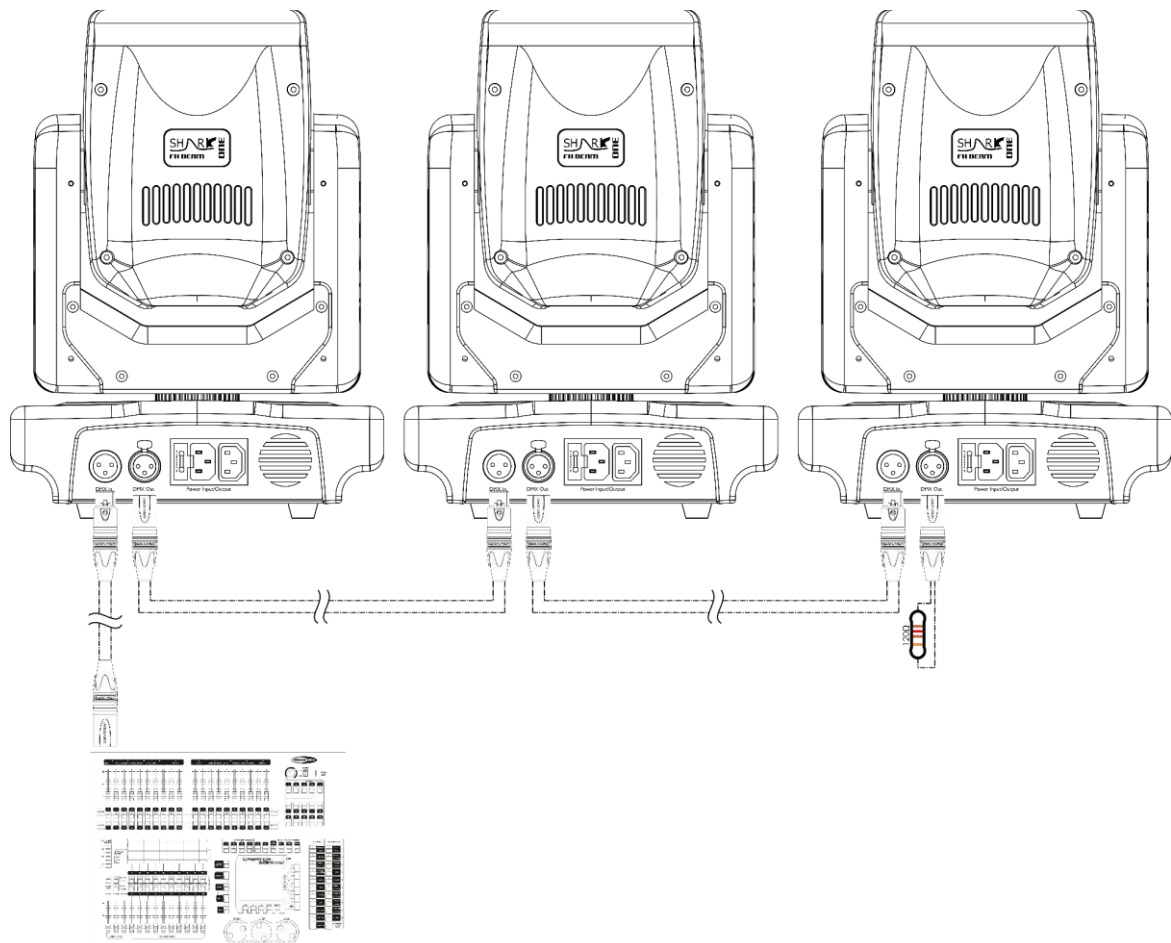

Note : Link all cables before connecting electric power

Fig. 04

Fixture Linking

You will need a serial data link to run light shows of one or more fixtures using a DMX-512 controller or to run synchronized shows of two or more fixtures set to a master/slave operating mode. The combined number of channels required by all the fixtures on a serial data link determines the number of fixtures the data link can support.

- Important:** Fixtures on a serial data link must be daisy-chained in a single line. To comply with the EIA-485 standard, no more than 30 devices should be connected on one data link. Connecting more than 30 fixtures on one serial data link without the use of a DMX optically isolated splitter may result in deterioration of the digital DMX signal.
- 
- Maximum recommended DMX data link distance: 100 meters
 - Maximum recommended number of fixtures on a DMX data link: 30 fixtures
 - Maximum recommended number of devices on a power link @120V: 6 fixtures
 - Maximum recommended number of devices on a power link @230V: 13 fixtures

Data Cabling

To link fixtures together, you must obtain data cables. You can purchase DAP Audio certified DMX cables directly from a dealer/distributor or construct your own cable. If you choose to create your own cable, please use data-grade cables that can carry a high quality signal and are less prone to electromagnetic interference.

DAP Audio DMX Data Cables

- DAP Audio Basic microphone cable for allround use. bal. XLR/M 3-pin > XLR/F 3-pin. **Ordercode** FL01150 (1,5 m), FL013 (3 m), FL016 (6 m), FL0110 (10 m), FL0115 (15 m), FL0120 (20 m).
- DAP Audio X-type data cable XLR/M 3-pin > XLR/F 3-pin. **Ordercode** FLX0175 (0,75 m), FLX01150 (1,5 m), FLX013 (3 m), FLX016 (6 m), FLX0110 (10 m).
- DAP Audio cable for the demanding user with exceptional audio-qualities and connector made by Neutrik®. **Ordercode** FL71150 (1,5 m), FL713 (3 m), FL716 (6 m), FL7110 (10 m).
- DAP Audio cable for the demanding user with exceptional audio-qualities and connector made by Neutrik®. **Ordercode** FL7275 (0,75 m), FL72150 (1,5 m), FL723 (3 m), FL726 (6 m), FL7210 (10 m).
- DAP Audio 110 Ohm cable with digital signal transmission. **Ordercode** FL0975 (0,75 m), FL09150 (1,5 m), FL093 (3 m), FL096 (6 m), FL0910 (10 m), FL0915 (15 m), FL0920 (20 m).

The Shark Beam FX One can be operated with a DMX controller in **control mode** or without a DMX controller in **stand-alone mode**.

Control Panel

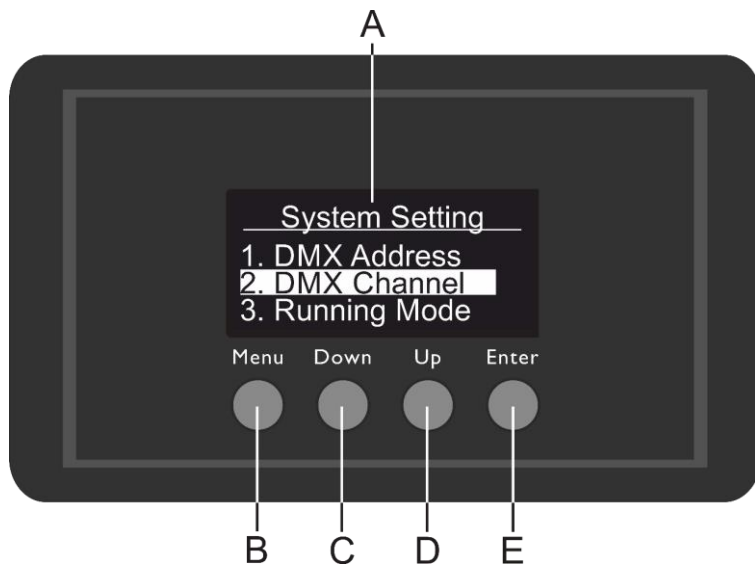

- A) OLED display
- B) MENU button
- C) DOWN button
- D) UP button
- E) ENTER button

Fig. 05

Control Mode

The fixtures are individually addressed on a data-link and connected to the controller. The fixtures respond to the DMX signal from the controller. (When you select the DMX address and save it, the controller will display the saved DMX address, next time.)

DMX Addressing

The control panel on the front side of the base allows you to assign DMX fixture addresses, which is the first channel with which the Shark will respond to the controller.

Please note, when you use the controller, the unit has **16** channels.

When using multiple Sharks, make sure you set the DMX addresses right.

Therefore, the DMX address of the first Shark should be **1(001)**; the DMX address of the second Shark should be **1+16=17 (017)**; the DMX address of the third Shark should be **17+16=33 (033)**, etc. Please, be sure that you do not have any overlapping channels in order to control each Shark correctly. If two or more Sharks are addressed similarly, they will work similarly.

Controlling:

After having addressed all Shark fixtures, you may now start operating these via your lighting controller.

Note: After switching on, the Shark will automatically detect whether DMX 512 data is received or not.

If there is no data received at the DMX-input, the "LED " on the control panel will not flash.

If not, the problem may be:

- The XLR cable from the controller is not connected with the input of the Shark Beam FX One.
- The controller is switched off or defective, the cable or connector is defective, or the signal wires are swapped in the input connector.

Note: It is necessary to insert an XLR termination plug (with 120 Ohm) in the last fixture in order to ensure proper transmission on the DMX data link.

Display Off after 30 seconds

When no button is pressed for 30 seconds, the display will turn off.

To light up the display, you have to press the MENU, ENTER, UP or DOWN button.

Once you have pressed the button, the display will light up.

Menu Overview

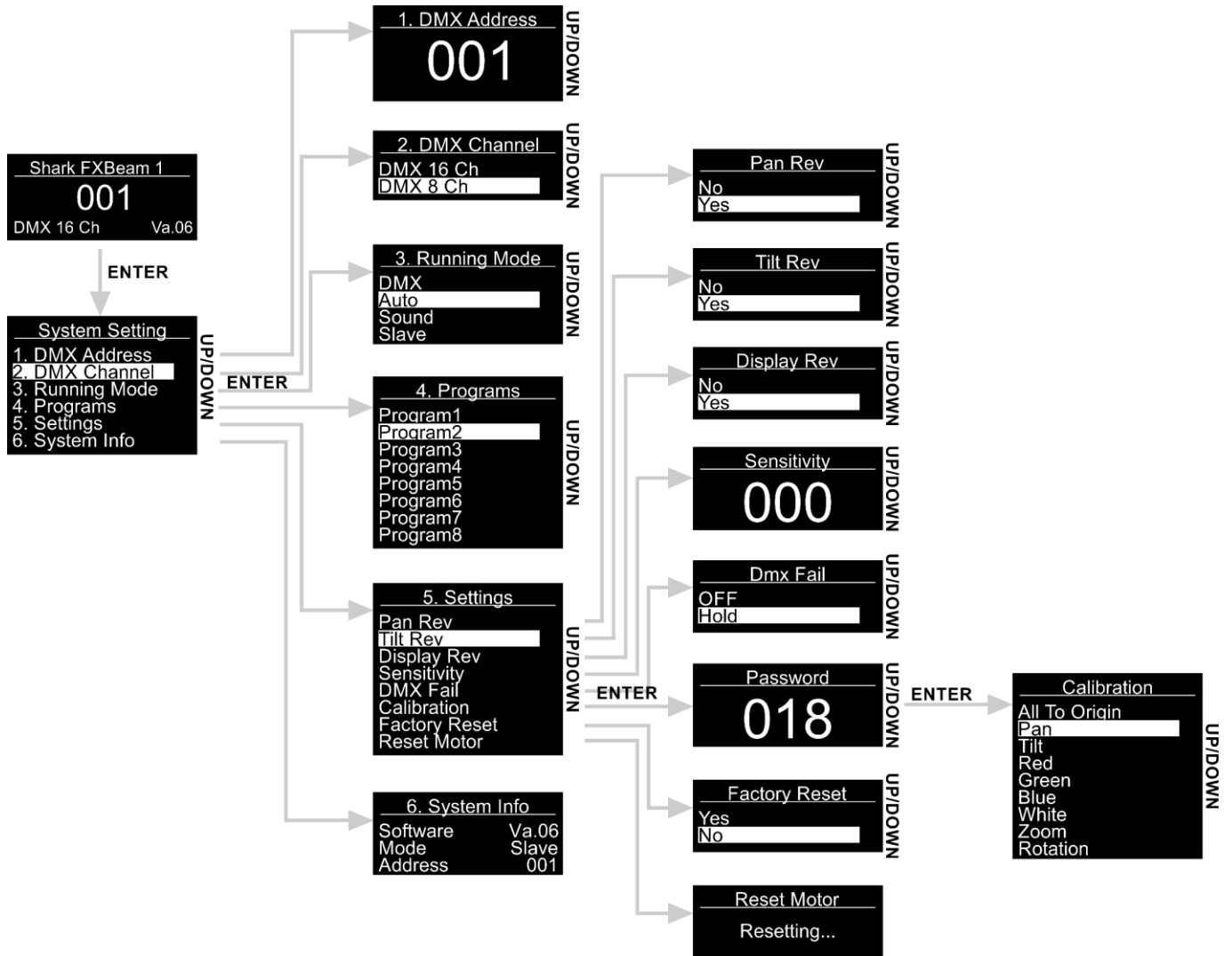

Main Menu Options

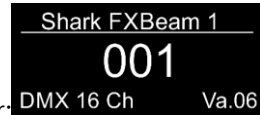

- 01) Upon start-up, the Shark will show its current version number.
- 02) Press the **ENTER** button to open main menu.
- 03) Press the **UP/DOWN** buttons to scroll through the menu. The display will show:



- 04) Press the **ENTER** button to open the desired menu.
- 05) Press the **MENU** button to return to the previous menu.

1. DMX Address

With this menu you can set the DMX address.

- 01) In main menu, press the **UP/DOWN** buttons until the display shows DMX ADDRESS.
- 02) Press the **ENTER** button to open the menu.
- 03) Press the **UP/DOWN** buttons to select the required address from 001-512.
- 04) Press the **ENTER** button to confirm the address.

2. DMX Channel

With this menu you can set the desired DMX channel mode.

- 01) In main menu, press the **UP/DOWN** buttons until the display shows DMX CHANNEL.
- 02) Press the **ENTER** button to open the menu.
- 03) Press the **UP/DOWN** buttons to select one of the 2 DMX channel modes:
 - 16-channel mode
 - 8-channel mode

- 04) Press the **ENTER** button to confirm your choice.

3. Running Mode

With this menu you can set the desired operation mode.

- 01) In main menu, press the **UP/DOWN** buttons until the display shows RUNNING MODE.
- 02) Press the **ENTER** button to open the menu.
- 03) Press the **UP/DOWN** buttons to select one of the 4 operation modes. The display will show:

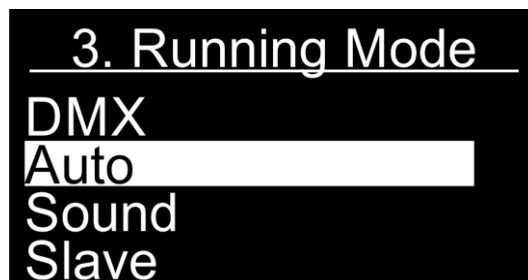

- 04) The operation modes are:
- DMX: The Shark can be controlled via DMX controller.
 - Auto: The Shark will run the built-in programs.
 - Sound: The Shark will react to the beat of the background music.
 - Slave: If set to Slave, the Shark will react the same as the master device.
- 05) Press the **ENTER** button to confirm your choice.

4. Programs

With this menu you can run individual built-in programs.

- 01) In main menu, press the **UP/DOWN** buttons until the display shows PROGRAMS.
02) Press the **ENTER** button to open the menu.
03) Press the **UP/DOWN** buttons to select one of the 8 built-in programs.

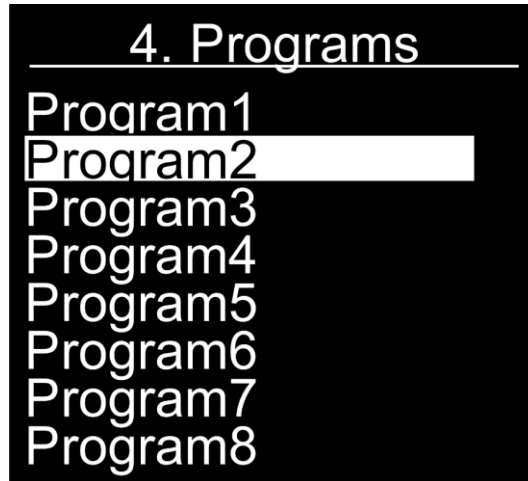

- 04) Press the **ENTER** button to confirm your choice.
05) The device will now run the chosen built-in program.

5. Settings

With this menu you can set the Shark's settings.

- 01) In main menu, press the **UP/DOWN** buttons until the display shows SETTINGS.
02) Press the **ENTER** button to open the menu.
03) Press the **UP/DOWN** buttons to select the desired submenu. The display will show:

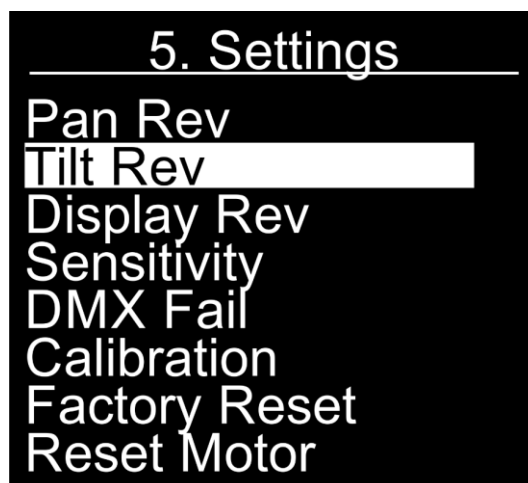

- 04) Press the **ENTER** button to enter the desired submenu.
05) The submenus are:
- Pan Rev: Pan reverse. Press the **UP/DOWN** buttons to choose between NO/YES.
 - Tilt Rev: Tilt reverse. Press the **UP/DOWN** buttons to choose between NO/YES.
 - Display Rev: Display reverse. Press the **UP/DOWN** buttons to choose between NO/YES.

- Sensitivity: Sound sensitivity. Press the **UP/DOWN** buttons to set between 0-100, from OFF to high sound sensitivity.
- DMX Fail: The Shark's behavior in case of a DMX failure. Press the **UP/DOWN** buttons to choose between OFF (light output will be cut off) and HOLD (the Shark will use the last working DMX signal, ensuring uninterrupted performance).
- Calibration: See [5.1. Calibration](#) for more information.
- Factory Reset: Restore default settings. Press the **UP/DOWN** buttons to choose between NO/YES.
- Reset Motor: Reset the motor responsible for the movement of the moving head.

06) Once you have adjusted the settings, press the **ENTER** button to save changes.

5.1. Calibration

With this menu you can set the initial parameters of the Shark.

01) Once you have chosen CALIBRATION (see above) press the **ENTER** button to open the menu.

02) You will now need to insert the password, in order to access the menu. Press the **UP/DOWN** buttons until the display shows **018** and press the **ENTER** button to confirm. The display will show:



03) The submenus are:

- All To Origin: Restore default calibration settings.
- Pan: Set the initial pan position.
- Tilt: Set the initial tilt position.
- Red: Set the initial Red dimmer brightness.
- Green: Set the initial Green dimmer brightness.
- Blue: Set the initial Blue dimmer brightness.
- White: Set the initial White dimmer brightness.
- Zoom: Set the initial zoom.
- Rotation: Set the initial rotation.

04) Once you have chosen the option which you would like to adjust, press the **ENTER** button to open the menu. The adjustment ranges are from 0-120 (for pan, tilt) and from 0-255 (for red, green, blue, white, zoom, rotation).

05) Press the **UP/DOWN** buttons to adjust settings and press the **ENTER** button to save changes.

6. System Info

With this menu you can monitor the status of the Shark.

- 01) In main menu, press the **UP/DOWN** buttons until the display shows SYSTEM INFO.
- 02) Press the **ENTER** button to open the menu. The display will show:

```
6. System Info
-----
Software      Va.06
Mode          Slave
Address       001
```

- 03) It is now possible to view the current software version, currently active operation mode and the DMX starting address.

Remote Control



Button	Function	Description
	ON/OFF	Double-press the button (within 5 seconds) to switch IR mode ON or OFF.
	Reset	Press the button to reset settings.
	LEDs ON/OFF	Press the button to switch the LEDs ON/OFF.
	RGBW brightness	Press the buttons to set the LED brightness for each color (RGBW). There are 8 steps (0-100%).
	Color macro	Press the button to switch color macros.
	Color temperature	Press the button to adjust the color temperature.
	Zoom +/-	Press the buttons to set the zoom. There are 8 steps (0-100%).
	Beam rotation	Press the button to set beam rotation, from slow to fast.
	Strobe frequency	Press the button to set the strobe frequency. There are 8 steps (from low to high frequency).
	Dimmer	Press the button to set dimmer brightness. There are 8 steps (0-100%).
	Clear settings	Press the button to clear RGBW, macro, color temperature, zoom, rotation, strobe and dimmer.
	Function buttons	Press the buttons while in Auto, Sound-controlled or Pan/tilt manual mode.
	Auto mode	Press the button to activate Auto mode. Press the 1-8 buttons to select the desired built-in program.
	Sound-controlled mode	Press the button to activate Sound-controlled mode. Press the 1-9 buttons to set sound sensitivity (from low to high sensitivity).
	Pan/tilt manual	Press the button to activate manual positioning. Pan/tilt will be reset to their center position. Press the 5, 6, 8, 9 buttons to manually set pan/tilt.

DMX Channels

8 channels

Channel 1 – Horizontal movement (Pan)

Move the slider up, in order to move head horizontally (PAN).
Gradual head adjustment from one end of the slider to the other (0-255, 128-center).
The head can be turned by 540° and stopped at any position you wish.

Channel 2 – Vertical movement (Tilt)

Move the slider up, in order to move head vertically (TILT).
Gradual head adjustment from one end of the slider to the other (0-255, 128-center).
The head can be turned by 270° and stopped at any position you wish.

Channel 3 – Dimmer

0-255 Dimmer intensity, from dark to brightest

Channel 4 – Strobe/Shutter ⚠ CH3 must be open ⚠

0-9 Shutter open
10-250 Strobe ON, from low to high frequency
251-255 Shutter open

Channel 5 – Color Macros ⚠ CH3 must be open and CH4 must be set between 251-255 ⚠

0-10 Not functional
11-20 Red (R255, G000, B000, W000)
21-30 Green (R000, G255, B000, W000)
31-40 Blue (R000, G000, B255, W000)
41-50 White (R000, G000, B000, W255)
51-60 Red+White (R255, G000, B000, W255)
61-70 Green+White (R000, G255, B000, W255)
71-80 Blue+White (R000, G000, B255, W255)
81-90 Red+Green (R255, G255, B000, W000)
91-100 Green+Blue (R000, G255, B255, W000)
101-110 Red+Blue (R255, G000, B255, W000)
111-120 Red+Green+Blue (R255, G255, B255, W000)
121-130 Green+Blue+White (R000, G255, B255, W255)
131-140 Red+Blue+White (R255, G000, B255, W255)
141-150 Red+Green+Blue+White (R255, G255, B255, W255)
151-200 Color switch, from slow to fast
201-255 Color flow, from slow to fast

Channel 6 – Zoom

0-255 Gradual zoom adjustment, from small to big

Channel 7 – Beam

0-100 Beam effect, from closed to open (0-90°)
101-133 Beam bouncing, from slow to fast
134-194 Beam counterclockwise rotation, from fast to slow
195-255 Beam clockwise rotation, from slow to fast

Channel 8 – Functions

0-10	Not functional
11-20	Built-in program 1
21-30	Built-in program 2
31-40	Built-in program 3
41-50	Built-in program 4
51-60	Built-in program 5
61-70	Built-in program 6
71-80	Built-in program 7
81-90	Built-in program 8
91-230	Sound-controlled mode, from OFF to high sound sensitivity
231-240	Reset (after 3 seconds)
241-255	Not functional

16 channels

Channel 1 – Horizontal movement (Pan)

Move the slider up, in order to move head horizontally (PAN).
Gradual head adjustment from one end of the slider to the other (0-255, 128-center).
The head can be turned by 540° and stopped at any position you wish.

Channel 2 – Pan fine 16 bit

Channel 3 – Vertical movement (Tilt)

Move the slider up, in order to move head vertically (TILT).
Gradual head adjustment from one end of the slider to the other (0-255, 128-center).
The head can be turned by 270° and stopped at any position you wish.

Channel 4 – Tilt fine 16 bit

Channel 5 – PAN/TILT Speed

0-255 From Max Speed (0) to Min. Speed (255)

Channel 6 – Dimmer

0-255 Dimmer intensity, from dark to brightest

Channel 7 – Strobe/Shutter CH6 must be open

0-9 Shutter open
10-250 Strobe ON, from low to high frequency
251-255 Shutter open

Channel 8 – Red Dimmer intensity

0-255 Gradual adjustment Red from 0-100%

Channel 9 – Green Dimmer intensity

0-255 Gradual adjustment Green from 0-100%

Channel 10 – Blue Dimmer intensity

0-255 Gradual adjustment Blue from 0-100%

Channel 11 – White Dimmer intensity

0-255 Gradual adjustment White from 0-100%

Channel 12 – Color Temperature

0-255 Gradual adjustment, from 0-100%

Channel 13 – Color Macros CH6 must be open and CH7 must be set between 251-255

0-10	Not functional
11-20	Red (R255, G000, B000, W000)
21-30	Green (R000, G255, B000, W000)
31-40	Blue (R000, G000, B255, W000)
41-50	White (R000, G000, B000, W255)
51-60	Red+White (R255, G000, B000, W255)
61-70	Green+White (R000, G255, B000, W255)
71-80	Blue+White (R000, G000, B255, W255)
81-90	Red+Green (R255, G255, B000, W000)
91-100	Green+Blue (R000, G255, B255, W000)
101-110	Red+Blue (R255, G000, B255, W000)
111-120	Red+Green+Blue (R255, G255, B255, W000)
121-130	Green+Blue+White (R000, G255, B255, W255)
131-140	Red+Blue+White (R255, G000, B255, W255)
141-150	Red+Green+Blue+White (R255, G255, B255, W255)
151-200	Color switch, from slow to fast
201-255	Color flow, from slow to fast

Channel 14 – Zoom

0-255	Gradual zoom adjustment, from small to big
-------	--

Channel 15 – Beam

0-100	Beam effect, from closed to open (0-90°)
101-133	Beam bouncing, from slow to fast
134-194	Beam counterclockwise rotation, from fast to slow
195-255	Beam clockwise rotation, from slow to fast

Channel 16 – Functions

0-10	Not functional
11-20	Built-in program 1
21-30	Built-in program 2
31-40	Built-in program 3
41-50	Built-in program 4
51-60	Built-in program 5
61-70	Built-in program 6
71-80	Built-in program 7
81-90	Built-in program 8
91-230	Sound-controlled mode, from OFF to high sound sensitivity
231-240	Reset (after 3 seconds)
241-255	Not functional

Maintenance

The operator has to make sure that safety-related and machine-technical installations are to be inspected by an expert after every year in the course of an acceptance test.

The operator has to make sure that safety-related and machine-technical installations are to be inspected by a skilled person once a year.

The following points have to be considered during the inspection:

- 01) All screws used for installing the device or parts of the device have to be tightly connected and must not be corroded.
- 02) There may not be any deformations on housings, fixations and installation spots.
- 03) Mechanically moving parts like axles, eyes and others may not show any traces of wearing.
- 04) The electric power supply cables must not show any damages or material fatigue.

The Shark Beam FX One requires almost no maintenance. However, you should keep the unit clean. Otherwise, the fixture's light output will be significantly reduced. Disconnect the mains power supply, and then wipe the cover with a damp cloth. Do not immerse in liquid. Wipe lens clean with glass cleaner and a soft cloth. Do not use alcohol or solvents.

The front lens will require weekly cleaning, as smoke-fluid tends to build up residues, reducing the light output very quickly.

Keep connections clean. Disconnect electric power, and then wipe the DMX and audio connections with a damp cloth. Make sure connections are thoroughly dry before linking equipment or supplying electric power.

Replacing a Fuse

Power surges, short-circuit or inappropriate electrical power supply may cause a fuse to burn out. If the fuse burns out, the product will not function whatsoever. If this happens, follow the directions below.

- 01) Unplug the unit from electric power source.
- 02) Insert a screwdriver into the slot in the fuse cover. Gently pry up the fuse cover. The fuse will come out.
- 03) Remove the used fuse. If brown or unclear, it is burned out.
- 04) Insert the replacement fuse into the holder where the old fuse was. Reinsert the fuse cover. Be sure to use a fuse of the same type and specification. See the product specification label for details.

Troubleshooting

This troubleshooting guide is meant to help solve simple problems.

If a problem occurs, carry out the steps below in sequence until a solution is found. Once the unit operates properly, do not carry out following steps.

No Light

If the light effect does not operate properly, refer servicing to a technician.

Suspect three potential problem areas as: the power supply, the LEDs, the fuse.

- 01) Power supply. Check if the unit is plugged into an appropriate power supply.
- 02) The LEDs. Return the Shark to your Showtec dealer.
- 03) The fuse. Replace the fuse. See page 22 for replacing the fuse.
- 04) If all of the above appears to be O.K., plug the unit in again.
- 05) If you are unable to determine the cause of the problem, do not open the Shark, as this may damage the unit and the warranty will become void.
- 06) Return the device to your Showtec dealer.

No Response to DMX

Suspect the DMX cable or connectors, a controller malfunction, a light effect DMX card malfunction.

- 01) Check the DMX setting. Make sure that DMX addresses are correct.
- 02) Check the DMX cable: Unplug the unit; change the DMX cable; then reconnect to electrical power. Try your DMX control again.
- 03) Determine whether the controller or light effect is at fault. Does the controller operate properly with other DMX products? If not, take the controller in for repair. If so, take the DMX cable and the light effect to a qualified technician.

Problem	Probable cause(s)	Solution
One or more fixtures do not function at all	No power to the fixture	<ul style="list-style-type: none"> Check if power is switched on and cables are plugged in
	Primary fuse blown	<ul style="list-style-type: none"> Replace the fuse.
Fixtures reset correctly, but all respond erratically or not at all to the controller	The controller is not connected.	<ul style="list-style-type: none"> Connect controller.
	3-pin XLR Out of the controller does not match XLR Out of the first fixture on the link (i.e. signal is reversed)	<ul style="list-style-type: none"> Install a phase reversing cable between the controller and the first fixture on the link
Fixtures reset correctly, but some respond erratically or not at all to the controller	Poor data quality	<ul style="list-style-type: none"> Check data quality. If much lower than 100 percent, the problem may be a bad data link connection, poor quality or broken cables, missing termination plug, or a defective fixture disturbing the link
	Bad data link connection	<ul style="list-style-type: none"> Inspect connections and cables. Correct poor connections. Repair or replace damaged cables
	Data link not terminated with 120 Ohm termination plug	<ul style="list-style-type: none"> Insert termination plug in output jack of the last fixture on the link
	Incorrect addressing of the fixtures	<ul style="list-style-type: none"> Check address setting
	One of the fixtures is defective and disturbs data transmission on the link	<ul style="list-style-type: none"> Bypass one fixture at a time until normal operation is restored: unplug both connectors and connect them directly together. Have the defective fixture serviced by a qualified technician
	3-pin XLR Out on the fixtures does not match (pins 2 and 3 reversed)	<ul style="list-style-type: none"> Install a phase-reversing cable between the fixtures or swap pin 2 and 3 in the fixture that behaves erratically
No light or LEDs cut out intermittently	Fixture is too hot	<ul style="list-style-type: none"> Allow the fixture to cool down Clean the fan Make sure air vents are not blocked Turn up the air conditioning
	LEDs damaged	<ul style="list-style-type: none"> Disconnect the fixture and return it to your dealer
	The power supply settings do not match local AC voltage and frequency	<ul style="list-style-type: none"> Disconnect fixture. Check settings and correct if necessary

Product Specifications

Model:	Showtec Shark Beam FX One
Input voltage:	100-240V, 50/60Hz
Power consumption:	135W
DMX linking:	30pcs
Fuse:	F2AL/250V
Dimensions:	255 x 175 x 355 mm (LxWxH)
Weight:	5,8 kg
Operating and Programming:	
Signal pin OUT:	Pin 1 (earth), pin 2 (-), pin 3 (+)
DMX Mode:	8, 16 channels
Signal input:	3-pin XLR IN
Signal output:	3-pin XLR OUT
Electro-mechanical effects:	
Light source:	3 x 40W RGBW 4-in-1 LED
Lux @2m:	48300 (4°)
Beam angle:	4-60°
Dimmer:	0-100%
Strobe:	0-20Hz
Housing:	Metal & flame retardant plastic
DMX-control:	via standard DMX controller
Onboard:	OLED display for easy setup
Control:	Auto, Built-in programs, Sound-controlled, Master/Slave, DMX-512,
Pan range:	540°
Tilt range:	270°
Pan/Tilt resolution:	16bit
Zoom:	Motorized
Lens rotation:	Continuous
Connections:	3-pin XLR connectors IN/OUT & IEC power IN/OUT
Cooling:	Cooling fan
Color:	Black
Max. ambient temperature t_a :	40°C
Max. housing temperature t_B :	80°C
Minimum distance:	
Minimum distance from flammable surfaces:	0,5 m
Minimum distance to lighted object:	1 m

Design and product specifications are subject to change without prior notice.



Website: www.Showtec.info

Email: service@highlite.nl

Dimensions

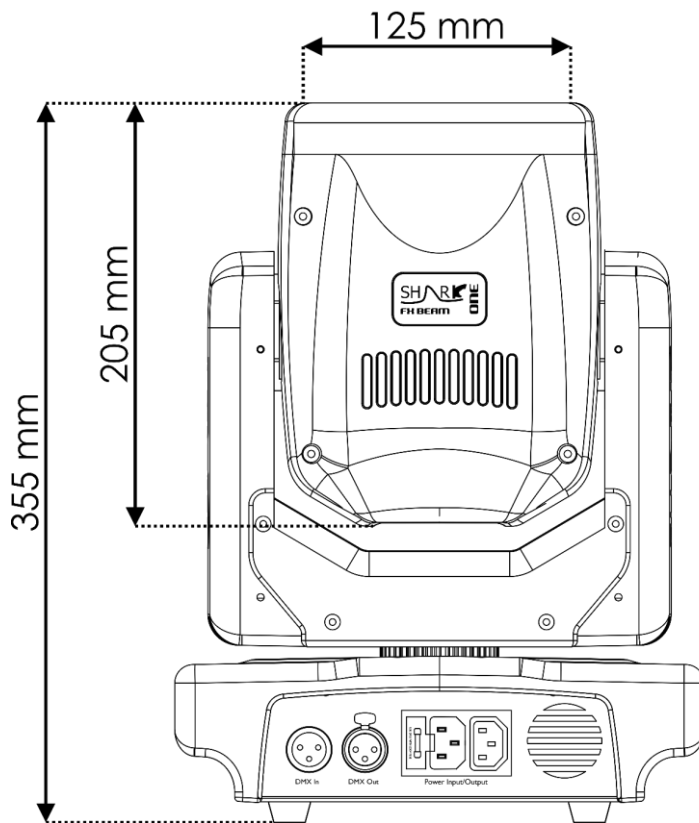
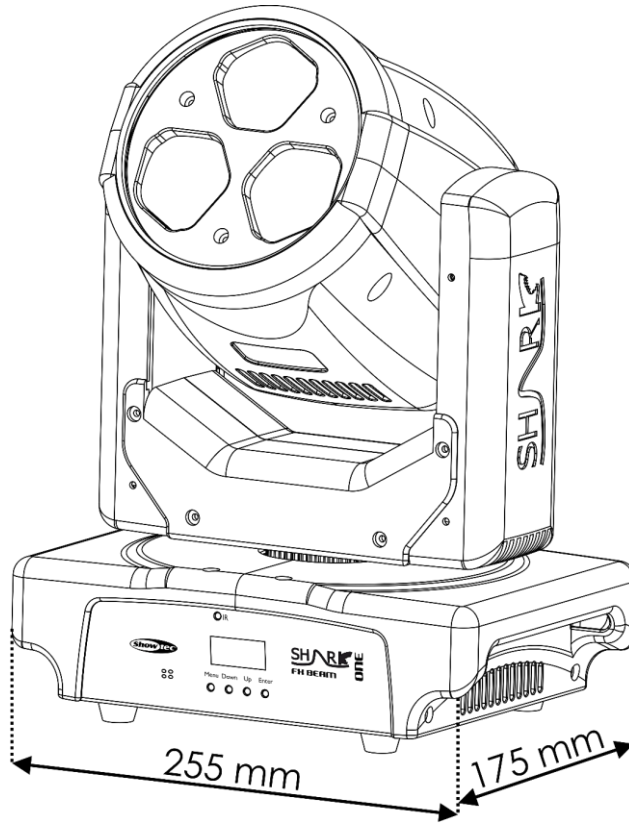



©2017 Showtec