

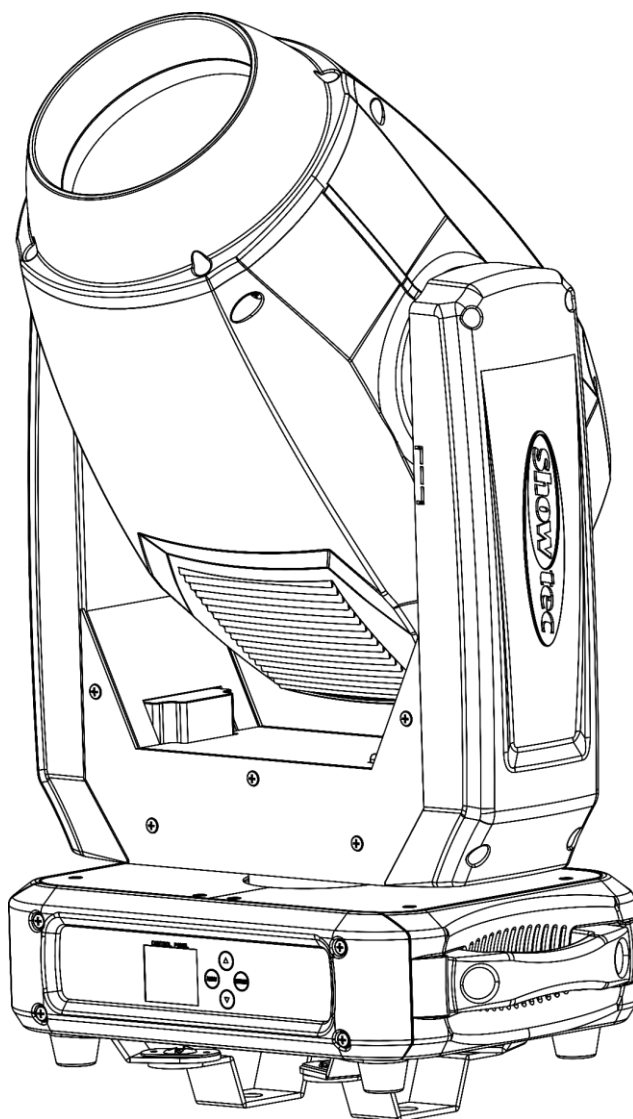

USER MANUAL



ENGLISH

Phantom 12R Hybrid

V1

Product code: 40080

Preface

Thank you for purchasing this Showtec product.

The purpose of this user manual is to provide instructions for the correct and safe use of this product.

Keep the user manual for future reference as it is an integral part of the product. The user manual shall be stored at an easily accessible location.

This user manual contains information concerning:

- Safety instructions
- Intended and non-intended use of the device
- Installation and operation of the device
- Maintenance procedures
- Troubleshooting
- Transport, storage and disposal of the device

Non-observance of the instructions in this user manual may result in serious injuries and damage of property.

©2021 Showtec. All rights reserved.

No part of this document may be copied, published or otherwise reproduced without the prior written consent of Highlite International.

Design and product specifications are subject to change without prior notice.

For the latest version of this document or for other language versions, please visit our website www.highlite.com or contact us at service@highlite.com.

Highlite International and its authorized service providers are not liable for any injury, damage, direct or indirect loss, consequential or economic loss or any other loss arising from the use of, or inability to use or reliance on the information contained in this document.

Table of contents

1. Introduction	4
1.1. Before Using the Product	4
1.2. Intended Use	4
1.3. Product Lifespan.....	4
1.4. Text Conventions	4
1.5. Symbols and Signal Words.....	5
1.6. Symbols on the Information Label	5
2. Safety	6
2.1. Warnings and Safety Instructions	6
2.2. Requirements for the User.....	9
3. Description of the Device	10
3.1. Front View	10
3.2. Back View	10
3.3. Base Plate	11
3.4. Product Specifications	12
3.5. Optional Accessories.....	13
3.6. Dimensions.....	13
4. Installation	13
4.1. Safety Instructions for Installation	13
4.2. Personal Protective Equipment	13
4.3. Installation Site Requirements	14
4.4. Rigging	14
4.5. Connecting to Power Supply	15
4.6. Power Linking of Multiple Devices.....	15
5. Setup	16
5.1. Warnings and Precautions	16
5.2. Stand-alone Setup	16
5.3. DMX Connection.....	16
5.3.1. DMX-512 Protocol	16
5.3.2. DMX Cables.....	17
5.3.3. Master/Slave Setup	17
5.3.4. DMX Linking.....	18
5.3.5. DMX Addressing.....	18
6. Operation	19
6.1. Safety Instructions for Operation	19
6.2. Control Modes	19
6.3. Control Panel	20
6.4. Start-up.....	20
6.5. Menu Overview	21
6.6. Main Menu Options	22
6.6.1. DMX Address	22
6.6.2. Built-in Programs Mode.....	23
6.6.2.1. DMX.....	23
6.6.2.2. Slave	23
6.6.2.3. Auto	23
6.6.2.4. Sound.....	23
6.6.2.5. Manual	24
6.6.3. Advanced Settings.....	25
6.6.3.1. Lamp Settings.....	26
6.6.3.2. Maintenance	26
6.6.4. System Information.....	27
6.7. DMX Channels	28
6.7.1. 14 Channels, 18 Channels	28

- 6.8. Gobo Wheels and Color Wheel32
 - 6.8.1. Replacing a Gobo From the Rotating Gobo Wheel33
 - 6.8.2. Gobo Size34
 - 6.8.3. Glass Gobo Orientation35
- 6.9. Lamp35
- 7. Troubleshooting36**
- 8. Maintenance37**
 - 8.1. Safety Instructions for Maintenance37
 - 8.2. Preventive Maintenance37
 - 8.2.1. Basic Cleaning Instructions37
 - 8.3. Corrective Maintenance38
 - 8.3.1. Replacing the Fuse38
 - 8.3.2. Replacing the Lamp39
 - 8.3.3. Adjusting the Lamp41
- 9. Deinstallation, Transportation and Storage42**
 - 9.1. Instructions for Deinstallation42
 - 9.2. Instructions for Transportation42
 - 9.3. Storage42
- 10. Disposal42**
- 11. Approval42**

1. Introduction

1.1. Before Using the Product



Important
Read and follow the instructions in this user manual before installing, operating or servicing this product.

The manufacturer will not accept liability for any resulting damages caused by the non-observance of this manual.

After unpacking, check the contents of the box. If any parts are missing or damaged, contact your Highlite International dealer.

Your shipment includes:

- Showtec Phantom 12R Hybrid
- 2 x quick-lock brackets
- Schuko to pro power cable (1,5 m)
- User manual

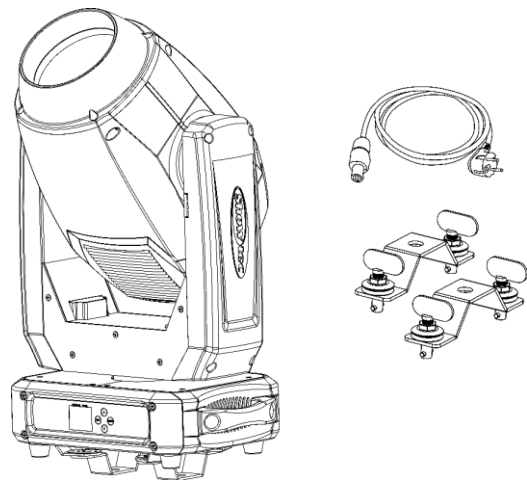

Fig. 01

1.2. Intended Use

This device is intended for professional use as a spot light moving head. It is suitable only for indoor installation. This device is not suitable for households and for general lighting.

Any other use, not mentioned under intended use, is regarded as non-intended and incorrect use.

1.3. Product Lifespan

This device is not designed for permanent operation. Disconnect the device from the electrical power supply when the device is not in operation. This will reduce the wear and will improve the device's lifespan.

1.4. Text Conventions









Throughout the user manual the following text conventions are used:

- Buttons: All buttons are in bold lettering, for example "Press the **UP/DOWN** buttons"
- References: References to chapters and parts of the device are in bold lettering, for example: "Refer to **2. Safety**", "turn the **adjustment screw (02)**"
- 0–255: Defines a range of values
- Notes: **Note:** (in bold lettering) is followed by useful information or tips

1.5. Symbols and Signal Words

Safety notes and warnings are indicated throughout the user manual by safety signs.





Always follow the instructions provided in this user manual.

-  **DANGER** Indicates an imminently hazardous situation which, if not avoided, will result in death or serious injury.
-  **WARNING** Indicates a potentially hazardous situation which, if not avoided, could result in death or serious injury.
-  **CAUTION** Indicates a potentially hazardous situation, which, if not avoided, may result in minor or moderate injury.
-  **Attention** Indicates important information for the correct operation and use of the product.
-  **Important** Read and observe the instructions in this document.
-  **Hot surface**
-  **Electrical hazard**
-  **Eye damage hazard**
-  Provides important information about the disposal of this product.

1.6. Symbols on the Information Label

This product is provided with an information label. The information label is located on the backside of the device.

The information label contains the following symbols:

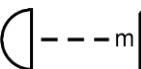
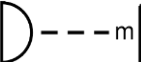
-  This device shall not be treated as household waste.
-  This device is designed for indoor use.
-  Read and observe the instructions in the user manual.
-  This device falls under IEC protection class I.
-  Minimum distance from lighted objects.
-  Minimum distance from other objects.

2. Safety



Important
Read and follow the instructions in this user manual before installing, operating or servicing this product.

The manufacturer will not accept liability for any resulting damages caused by the non-observance of this manual.

2.1. Warnings and Safety Instructions



DANGER
Danger for children

For adult use only. The device must be installed beyond the reach of children.

- Do not leave various parts of the packaging (plastic bags, polystyrene foam, nails, etc.) within children's reach. Packaging material is a potential source of danger for children.



DANGER
Electric shock caused by dangerous voltage inside

There are areas within the device where dangerous touch voltage may be present.

- Do not open the device or remove any covers.
- Do not operate the device if the covers or the housing are open. Before operation, check if the housing is firmly closed and all screws are tightly fastened.
- Disconnect the device from electrical power supply before service and maintenance, and when the device is not in use.



DANGER
Electric shock caused by short-circuit

This device falls under IEC protection class I.

- Make sure that the device is electrically connected to ground (earth). Connect the device only to a socket-outlet with ground (earth) connection.
- Do not cover the ground (earth) connection.
- Do not bypass the thermostatic switch or fuses.
- For replacement use fuses of the same type and rating only.
- Do not let the power cable come into contact with other cables. Handle the power cable and all connections with the mains with caution.
- Do not modify, bend, mechanically strain, put pressure on, pull or heat up the power cable.
- Make sure that the power cable is not crimped or damaged. Examine the power cable periodically for any defects.
- Do not immerse the device in water or other liquids. Do not install the device in a location where flooding may occur.
- Do not use the device during thunderstorms. Disconnect the device from the electrical power supply immediately.



WARNING
Risk of burns due to hot surface

The surface and the inner parts of the device can become very hot during operation.

- Do not touch the device during operation.
- Allow the device to cool down for at least 20 minutes before handling.



WARNING
Risk of epileptic shock

Strobe lighting can trigger seizures in photosensitive epilepsy. Sensitive persons should avoid looking at strobe lights.



CAUTION
Possible eye damage caused by high light intensity

Possibly hazardous optical radiation emitted from this device.

- Do not look at the operating light source. May be harmful to the eye.
- Do not look at the light source with optical instruments that may concentrate the light output.
- Make sure that persons are not looking directly into the light source when the device lights up suddenly. This can happen when the device is powered or when it receives DMX signal, or when certain menu items are selected.
- Disconnect power supply before servicing.
- Wear protective goggles if looking into light source during service or maintenance.



CAUTION
Risk of injury due to movement of the device

The head of the device can move quickly. Persons staying near the device could be injured or frightened.

- Make sure that there are no persons close to the device when you turn on the device and during operation.
- Keep body parts away from the moving parts of the device when servicing and during maintenance. Long hair or loose clothing can be entangled during the rotation of the moving head.



Attention
Power supply

- Before connecting the device to the power supply, make sure that the current, voltage and frequency match the input voltage, current and frequency specified on the information label on the device.
- Make sure that the cross-sectional area of the extension cords and power cables is sufficient for the required power consumption of the device.



Attention **General safety**

- Do not lift the device holding it by the projector head. This may damage the mechanics. Use the transport handles when handling the device.
- Do not insert objects into the air vents.
- Do not connect the device to a dimmer pack.
- Do not switch the device on and off in short intervals. This decreases the device's life.
- Do not shake the device. Avoid brute force when installing or operating the device.
- Change the lens or the lamp if they are visibly damaged to such an extent that their effectiveness is impaired, for example by cracks or deep scratches. Contact your Highlite International dealer for more information, as servicing can be performed only by instructed or skilled persons.
- If the device is dropped or struck, disconnect the device from the electrical power supply immediately.
- If the device is exposed to extreme temperature variations (e.g. after transportation), do not switch it on immediately. Let the device reach room temperature before switching it on, otherwise it may be damaged by the formed condensation.
- If the device fails to work properly, discontinue the use immediately.



Attention **Risk of fire**

The distance between the device and the lighted object should be at least 10 m.

- Do not aim the device towards flammable materials.
- Do not cover the lamp or lens.
- Do not place the device close to flammable liquids or gases.
- Keep away from flames.
- Do not install the device near direct heat sources.
- Always allow a free air space of at least 0,5 m around the device for ventilation.



Attention **Lamp can spontaneously explode**

A hot discharge lamp is under high pressure and can therefore spontaneously explode. The risk increases with the age, temperature and improper handling of the lamp.

If the lamp breaks, special safety precautions must be taken as mercury is released. Evacuate the area immediately and ventilate it.

- Replace the lamp if it has become damaged or thermally deformed.
- Do not install lamps with a higher wattage.
- Read the safety instructions that are included with the lamp before replacing the lamp.
- Let the lamp cool down for 20 minutes, before replacing the lamp.



Attention
For professional use only
This device shall be used only for the purposes it is designed for.

This device is designed to be used as a spot light moving head. Any incorrect use may lead to hazardous situations and result in injuries and material damage.

- This device is not suitable for households and for general lighting.
- This device is not designed for permanent operation.
- This device does not contain user-serviceable parts. Unauthorized modifications to the device will render the warranty void. Such modifications may result in injuries and material damage.



Attention
Before each use, examine the device visually for any defects.

Make sure that:

- All screws used for installing the device or parts of the device are tightly fastened and are not corroded.
- The safety devices are not damaged.
- There are no deformations on housings, fixations and installation points.
- The lens is not cracked or damaged.
- The power cables are not damaged and do not show any material fatigue.



Attention
Do not expose the device to conditions that exceed the rated IP class conditions.

This device is IP20 rated. IP (Ingress Protection) 20 class provides protection against solid objects greater than 12 mm, such as fingers, and no protection against harmful ingress of water.

2.2. Requirements for the User

This product may be used by ordinary persons. Maintenance may be carried by ordinary persons. Installation and service shall be carried out only by instructed or skilled persons. Contact your Highlite dealer for more information.

Instructed persons have been instructed and trained by a skilled person, or are supervised by a skilled person, for specific tasks and work activities associated with the installation, service and maintenance of this product, so that they can identify risks and take precautions to avoid them.

Skilled persons have training or experience, which enables them to recognize risks and to avoid hazards associated with the installation, service and maintenance of this product.

Ordinary persons are all persons other than instructed persons and skilled persons. Ordinary persons include not only users of the product but also any other persons that may have access to the device or who may be in the vicinity of the device.

3. Description of the Device

The Phantom 12R Hybrid is the bigger version of the Phantom 3R Hybrid. The Phantom 12R Hybrid is equipped with a 12-color color wheel, 16 static gobos and 8 rotating gobos.

3.1. Front View

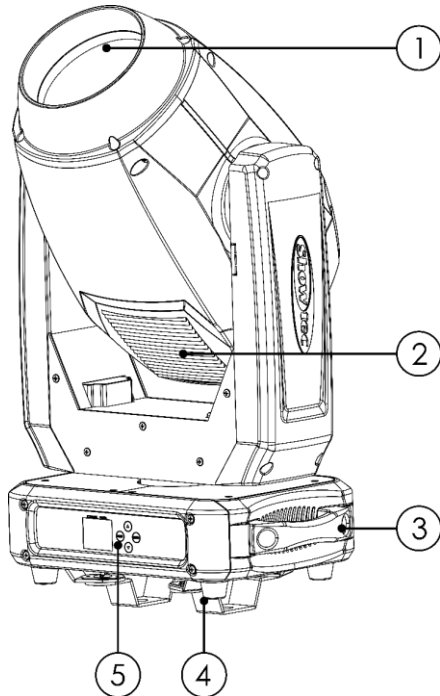

- 01) 1 x 300 W White Ushio lamp
- 02) Air vents
- 03) 2 x transport handles
- 04) Mounting brackets
- 05) Control panel: LCD display and control buttons

Fig. 02

3.2. Back View

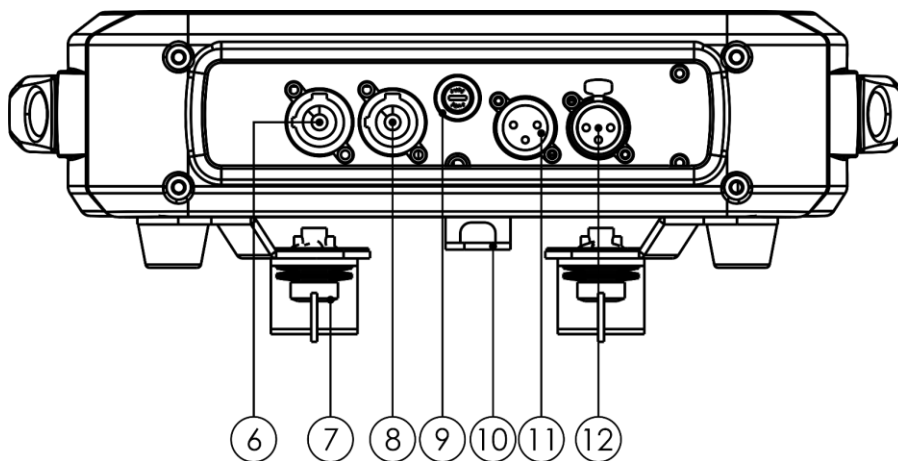
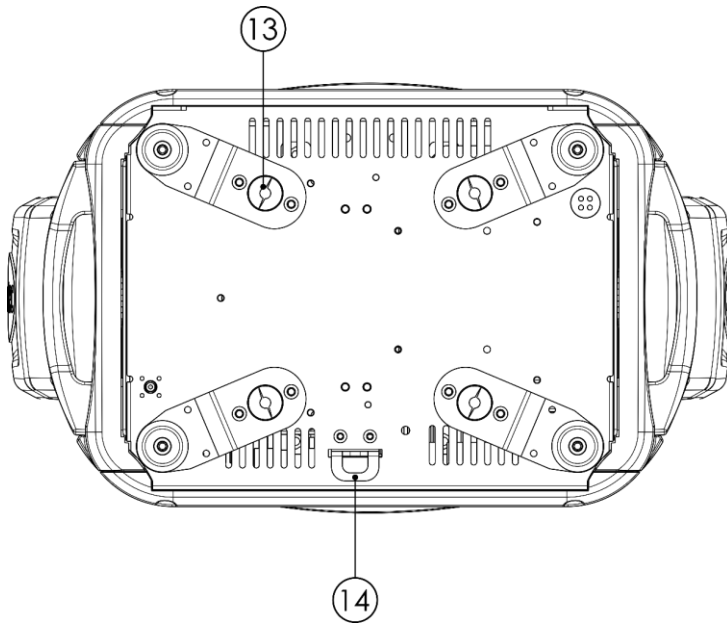

Fig. 03

- 06) Pro power connector (Blue) IN
- 07) Quick lock
- 08) Pro power connector (Gray) OUT
- 09) Fuse F6,3L/250 V
- 10) Safety eye
- 11) 3-pin DMX signal connector IN
- 12) 3-pin DMX signal connector OUT

3.3. Base Plate



- 13) 4 x mounting holes for quick-lock brackets
- 14) Safety eye

Fig. 04

3.4. Product Specifications

Model:	Phantom 12R Hybrid	
Electrical:		
Input voltage:	100–240 V AC, 50/60 Hz	
Power consumption:	400 W	
Fuse:	F6,3L/250 V	
Physical:		
Dimensions:	325 x 212 x 550 mm (L x W x H)	
Weight:	16,83 kg	
Movement:		
Pan:	540°	
Tilt:	270°	
Optics:		
Light source:	1 x Ushio NSL300 lamp, 300 W	
Life expectancy:	1500 h	
Source warm-up time:	5 min	
Source hot restart time:	5 min	
Light output:	8600 lm	
CRI:	80	
CCT:	7200 K	
Dimmer:	0–100 %	
Strobe:	0–15 Hz	
Beam angle:	2,2°–48,8°	
Zoom:	Motorized	
Focus:	Motorized	
Effects:		
Color wheel:	1 x 12 dichroic filters and white	
Static gobo wheel:	16 gobo patterns and open (metal)	
Rotating gobo wheel:	8 gobo patterns and 2 x open (glass+metal)	
Prism:	24-facet circular prism and 8-facet circular prism Prism overlay Prism Index & Rotate	
Operation and control:		
Control:	Stand-alone (auto, manual, sound-controlled) Master/Slave (auto, manual, sound-controlled) DMX-512	
DMX channels:	14, 18 channels	
Control panel:	LCD display and control buttons	
Connections:		
Power connections:	Power Pro connector (Blue) IN/(Gray)OUT	
Data connections:	3-pin DMX connectors IN/OUT	
Signal pinouts:	3-pin: pin 1 (ground), pin 2 (-), pin 3 (+)	
Construction:		
Housing:	Metal and flame-retardant plastic	
Color:	Black	
IP rating:	IP20	
Cooling:	Axial fan	
Thermal:		
Maximum ambient temperature t_a :	40 °C	
Maximum housing temperature t_c :	70 °C	
Minimum distance:		
Minimum distance from flammable surfaces:	10 m	
Minimum distance to lighted object:	10 m	

3.5. Optional Accessories

You can additionally purchase the following accessories:

Product code: [81019](#) (Ushio NSL300 lamp, 300 W)

3.6. Dimensions

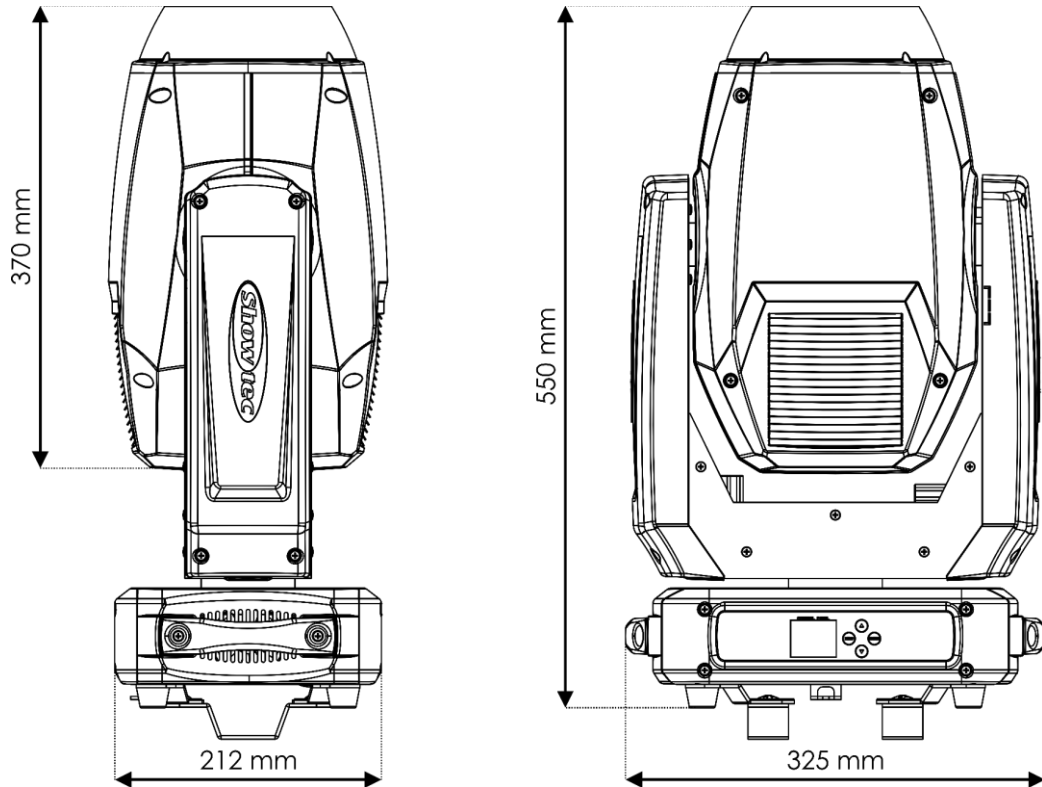

Fig. 05

4. Installation

4.1. Safety Instructions for Installation



WARNING
Incorrect installation can cause serious injuries and damage of property.

If trussing systems are used, installation must be carried out only by instructed or skilled persons.

Follow all applicable European, national and local safety regulations concerning rigging and trussing.

4.2. Personal Protective Equipment

During installation and rigging wear personal protective equipment in compliance with the national and site-specific regulations.

4.3. Installation Site Requirements

- The device must be installed only indoors.
- The device can be mounted to a truss or other rigging structure in any orientation.
- The minimum distance between the light output and the illuminated surface must be bigger than 10 m.
- The minimum distance to other objects must be bigger than 10 m.
- The maximum ambient temperature $t_a = 40\text{ °C}$ must never be exceeded.
- The relative humidity must not exceed 50 % with an ambient temperature of 40 °C .

4.4. Rigging

The device can be positioned on a flat surface or mounted to a truss or other rigging structure in any orientation. Make sure that all loads are within the pre-determined limits of the supporting structure.



CAUTION

Restrict the access under the work area during rigging and/or derigging.

To mount the device, follow the steps below:

- 01) Fasten the 2 quick lock brackets, supplied with the device, on the **mounting holes for quick lock brackets (13)**. You can position the quick lock brackets in two ways, as shown in Fig. 06.
- 02) Install the clamps, as shown in Fig. 07. Make sure that you use clamps suitable for attaching the device to a truss.

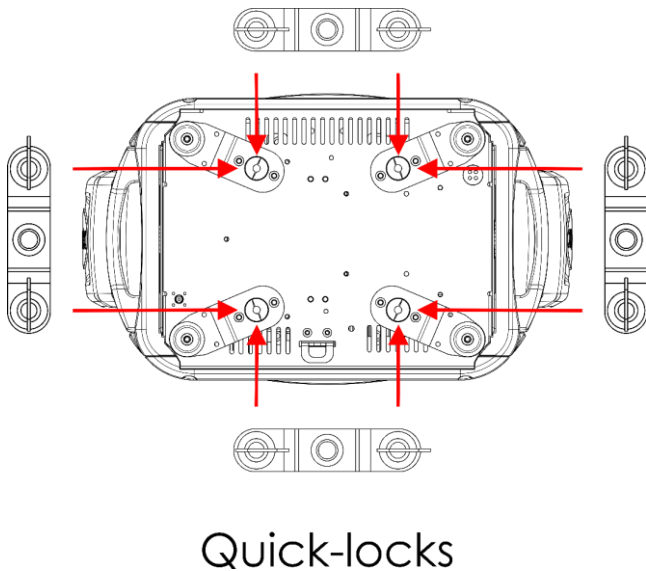

Fig. 06

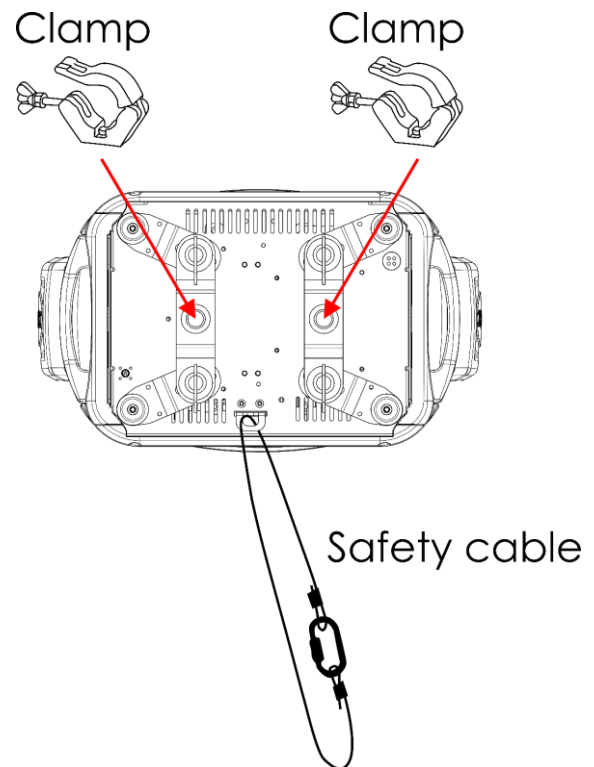

Fig. 07

- 03) Attach the device to the supporting structure. Make sure that the device cannot move freely.
- 04) Secure the device with a secondary suspension, for example a safety cable. Make sure that the secondary suspension can hold 10 times the weight of the device. If possible, the secondary suspension should be attached to a supporting structure independent of the primary suspension. Put the safety cable through the **safety eye (14)**, as shown in Fig. 07.

4.5. Connecting to Power Supply



DANGER
Electric shock caused by short-circuit

The device accepts AC mains power at 100–240 V and 50/60 Hz. Do not supply power at any other voltage or frequency to the device.

This device falls under IEC protection class I. Make sure that the device is always electrically connected to the ground (earth).

Before connecting the device to the socket-outlet:

- Make sure that the power supply matches the input voltage specified on the information label on the device.
- Make sure that the socket-outlet has ground (earth) connection.

Connect the device to the socket-outlet with the power plug. Do not connect the device to a dimmer circuit, as this may damage the device.

4.6. Power Linking of Multiple Devices

This device supports power linking. Power can be relayed to another device via the power OUT connector. Note that the input and the output connectors have different designs: one type cannot be connected to the other.

Power linking of multiple devices must be carried out only by instructed or skilled persons.



WARNING
Incorrect power linking may lead to overload of the electrical circuit and result in serious injuries and damage of property.

To prevent overload of the electrical circuit, when power linking multiple devices:

- Use cables with sufficient current-carrying capacity. The power cable supplied with the device is not suitable for power linking of multiple device.
- Make sure that the total current draw of the device and all connected devices does not exceed the rated capacity of the power cables and the circuit breaker.
- Do not link more devices on one power link than the maximum recommended number.

Maximum recommended number of devices:

- at 100–120 V: 2 devices
- at 200–240 V: 5 devices

5. Setup

5.1. Warnings and Precautions



Attention

Connect all data cables before supplying power.

Disconnect power supply before connecting or disconnecting data cables.

5.2. Stand-alone Setup

When the Phantom 12R Hybrid is not connected to a controller or to other devices, it functions as a stand-alone device. It can be operated manually or in auto mode.

For more information about the control modes, refer to **6.2. Control Modes** on page 19.

5.3. DMX Connection

5.3.1. DMX-512 Protocol

You need a DMX serial data link to run light shows of one or more devices using a DMX-512 controller or to run synchronized shows of two or more devices set in a master/slave operating mode.

The Phantom 12R Hybrid has 3-pin DMX signal IN and OUT connectors.

The pin assignment is as follows:

- 3-pin: pin 1 (ground), pin 2 (-), pin 3 (+)

Devices on a serial data link must be daisy-chained in a single line. The number of devices that you can control on one data link is limited by the combined number of the DMX channels of the connected devices and the 512 channels available in one DMX universe.

To comply with the TIA-485 standard, no more than 32 devices should be connected on one data link. In order to connect more than 32 devices on one data link, you must use a DMX optically isolated splitter/booster, otherwise this may result in deterioration of the DMX signal.

Note:

- Maximum recommended DMX data link distance: 300 m
- Maximum recommended number of devices on a DMX data link: 32 devices

5.3.2. DMX Cables

Shielded twisted-pair cables with 3-pin XLR connectors must be used for reliable DMX connection. You can purchase DMX cables directly from your Highlite International dealer or make your own cables.

If you use XLR audio cables for DMX data transmission, this may lead to signal degradation and unreliable operation of the DMX network.

When you make your own DMX cables, make sure that you connect the pins and wires correctly as shown in Fig. 08.

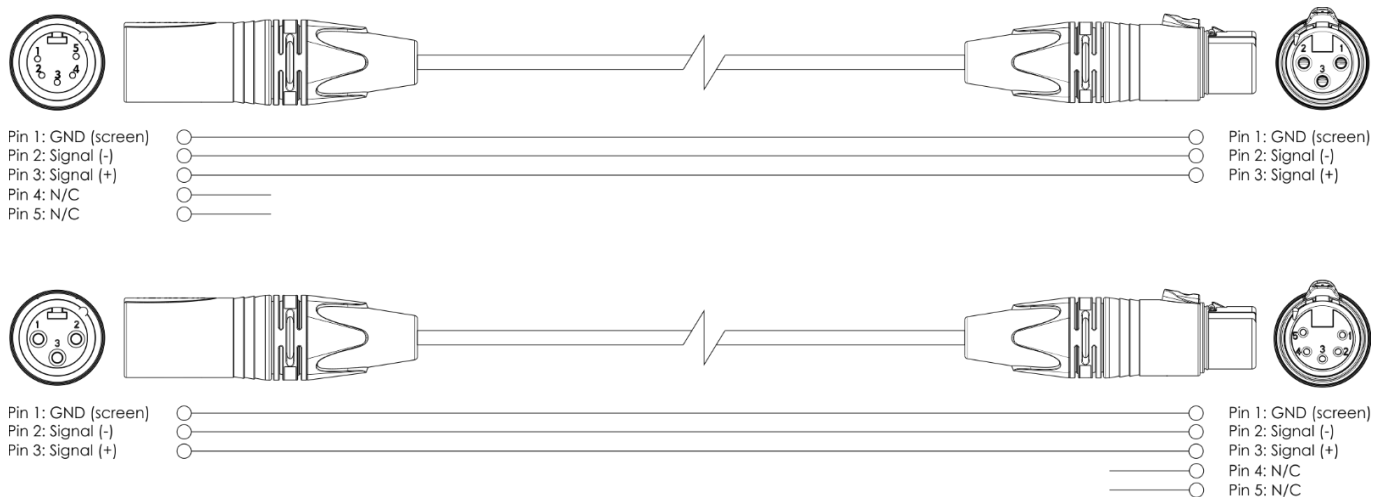

Fig. 08

5.3.3. Master/Slave Setup

The Phantom 12R Hybrid supports master/slave control mode. To connect multiple devices in master/slave setup, follow the steps below:

- 01) Connect the first device's DMX OUT connector to the second device's DMX IN connector.
- 02) Repeat step 1 to connect all devices as shown in Fig. 09. The first connected device will be automatically recognized as the master device.
- 03) Set all subsequent devices as slave devices. See **6.6.2.2. Slave** on page 23 for more information.
- 04) Connect a DMX terminator (120 Ω resistor) to the DMX OUT connector of the last device in the setup.

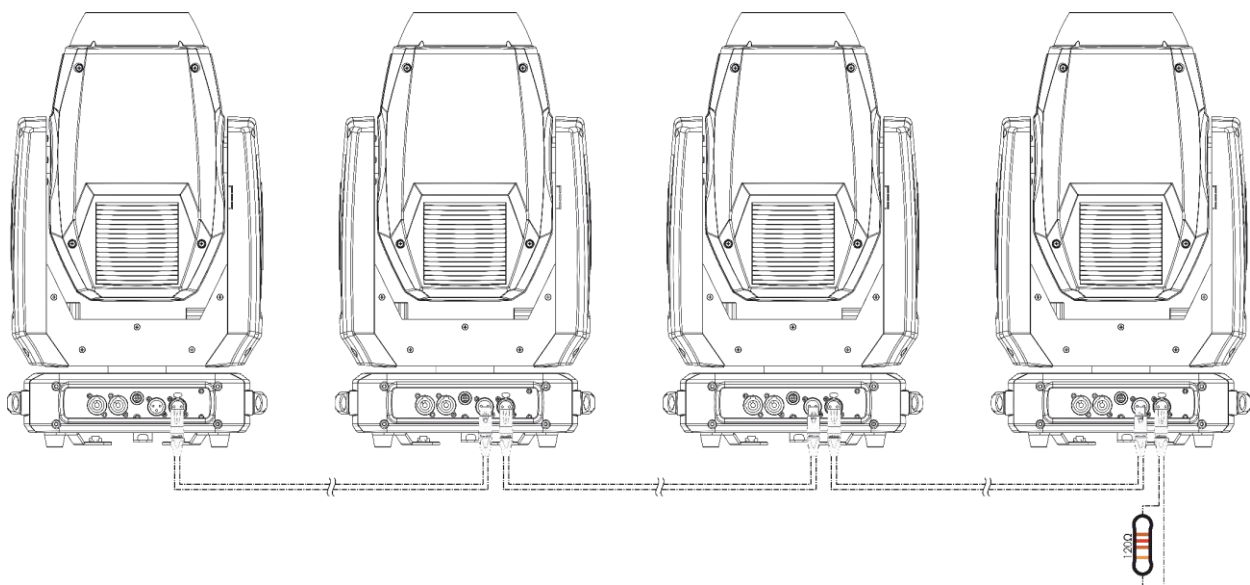

Fig. 09

5.3.4. DMX Linking

To connect multiple devices on one DMX data link, follow the steps below:

- 01) Use a 3-pin DMX cable to connect the DMX OUT connector of the lighting controller to the DMX IN connector of the first device.
- 02) Connect the first device's DMX OUT connector to the second device's DMX IN connector with a 3-pin DMX cable.
- 03) Repeat step 2 to connect all devices in a daisy-chain as shown in Fig. 10.
- 04) Connect a DMX terminator (120 Ω resistor) to the DMX OUT connector of the last device on the data link.

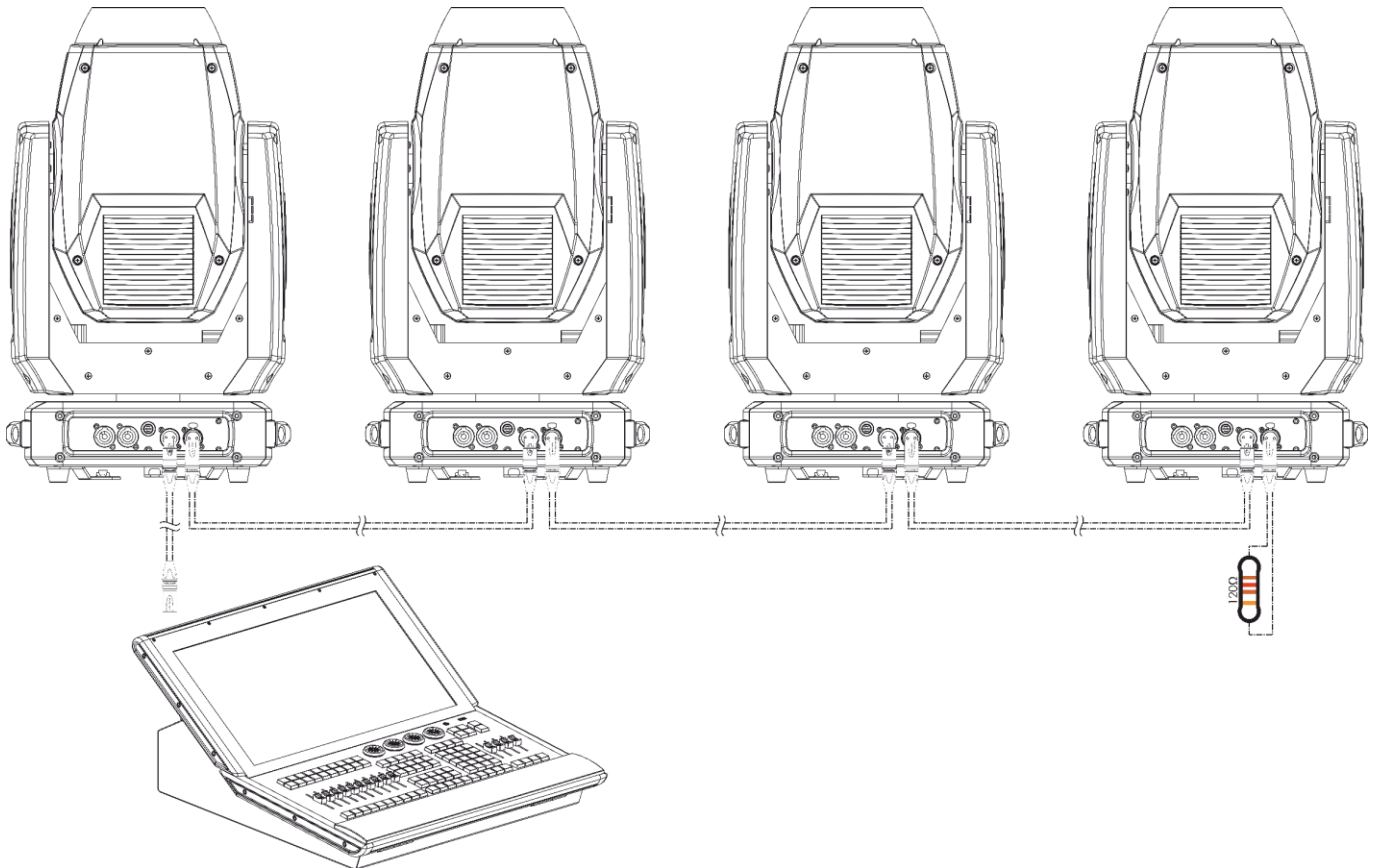

Fig. 10

5.3.5. DMX Addressing

In a setup with multiple devices, make sure that you set the DMX starting address of each device correctly. The Phantom 12R Hybrid has 2 personalities: 14 and 18 channels.

If you want to connect multiple devices on one data link and use them in 18-channel mode, for example, follow the steps below:

- 01) Set the starting address of the 1st device on the data link to 1 (001).
- 02) Set the starting address of the 2nd device on the data link to 19 (019), as $1 + 18 = 19$.
- 03) Set the starting address of the 3rd device on the data link to 37 (037) as $19 + 18 = 37$.
- 04) Continue assigning the starting addresses of the remaining devices by adding each time 18 to the previous number.

Make sure that you do not have any overlapping channels in order to control each Phantom 12R Hybrid correctly. If two or more devices are addressed similarly, they will work similarly.

6. Operation

6.1. Safety Instructions for Operation



Attention

This device must be used only for the purposes it is designed for.

This device is intended for professional use as a spot light moving head. It is suitable only for indoor installation. This device is not suitable for households and for general lighting.

Any other use, not mentioned under intended use, is regarded as non-intended and incorrect use.



Attention

Power supply

Before connecting the device to the power supply, make sure that the current, voltage and frequency match the input voltage, current and frequency specified on the information label on the device.

6.2. Control Modes

The Phantom 12R Hybrid supports the following control modes:

- Stand-alone: Auto operation mode (auto programs), manual operation mode, sound-controlled operation mode (auto program)
- Master/Slave: Auto operation mode (auto programs), manual operation mode, sound-controlled operation mode (auto program)
- DMX-512: 14, 18 channels

For more information about how to connect the devices, refer to **5. Setup** on pages 16–18.

To operate the device manually as a stand-alone device or in a master/slave setup, adjust all the settings in Manual menu. See **6.6.2.5. Manual** on page 24 for more information.

To run the built-in programs in auto operation mode without a DMX controller, activate Auto menu. See **6.6.2.3. Auto** on page 23 for more information.

For more information about sound-controlled operation mode see **6.6.2.4. Sound** on page 23.

To operate the device with a DMX controller:

- 01) Set the DMX starting address of the device in the DMX Address menu. See **5.3.5. DMX Addressing** on page 18 and **6.6.1. DMX Address** on page 22.
- 02) Select the DMX channel mode. See **6.6.2.1. DMX** on page 23 for more information. See **6.7. DMX Channels** on page 28 for complete overview of all DMX channels.

6.3. Control Panel

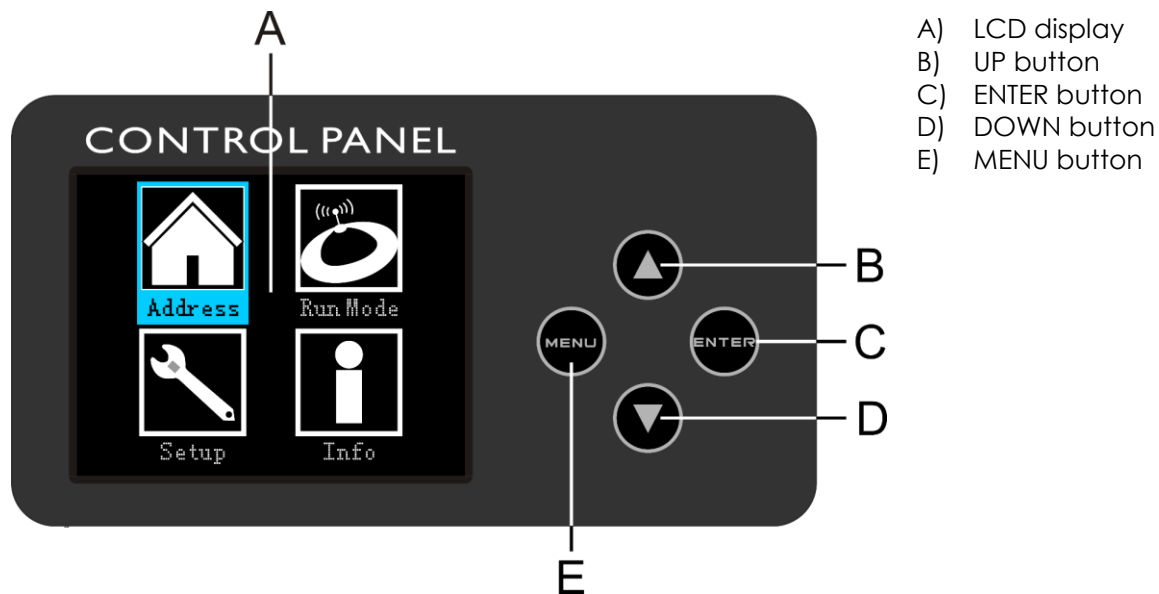

Fig. 11

- Use the **MENU** button to exit the current submenu, to return to the Main Menu and to return to the start screen.
- Use the **UP/DOWN** buttons to navigate through the menus or to increase/decrease numeric values.
- Use the **ENTER** button to open the desired menu, to confirm your choice or to set the currently selected value.

6.4. Start-up

Upon start-up the display will show a splash screen with the logo of Showtec. Immediately afterwards the display will show the start screen. The start screen provides information about the currently active operation mode and the current pan/tilt angle setting. Press the **ENTER** button to enter the main menu. The display will show:



Note: If no button is pressed, after 30 seconds of inactivity the display will turn off. Press any button to turn the display on.

6.5. Menu Overview

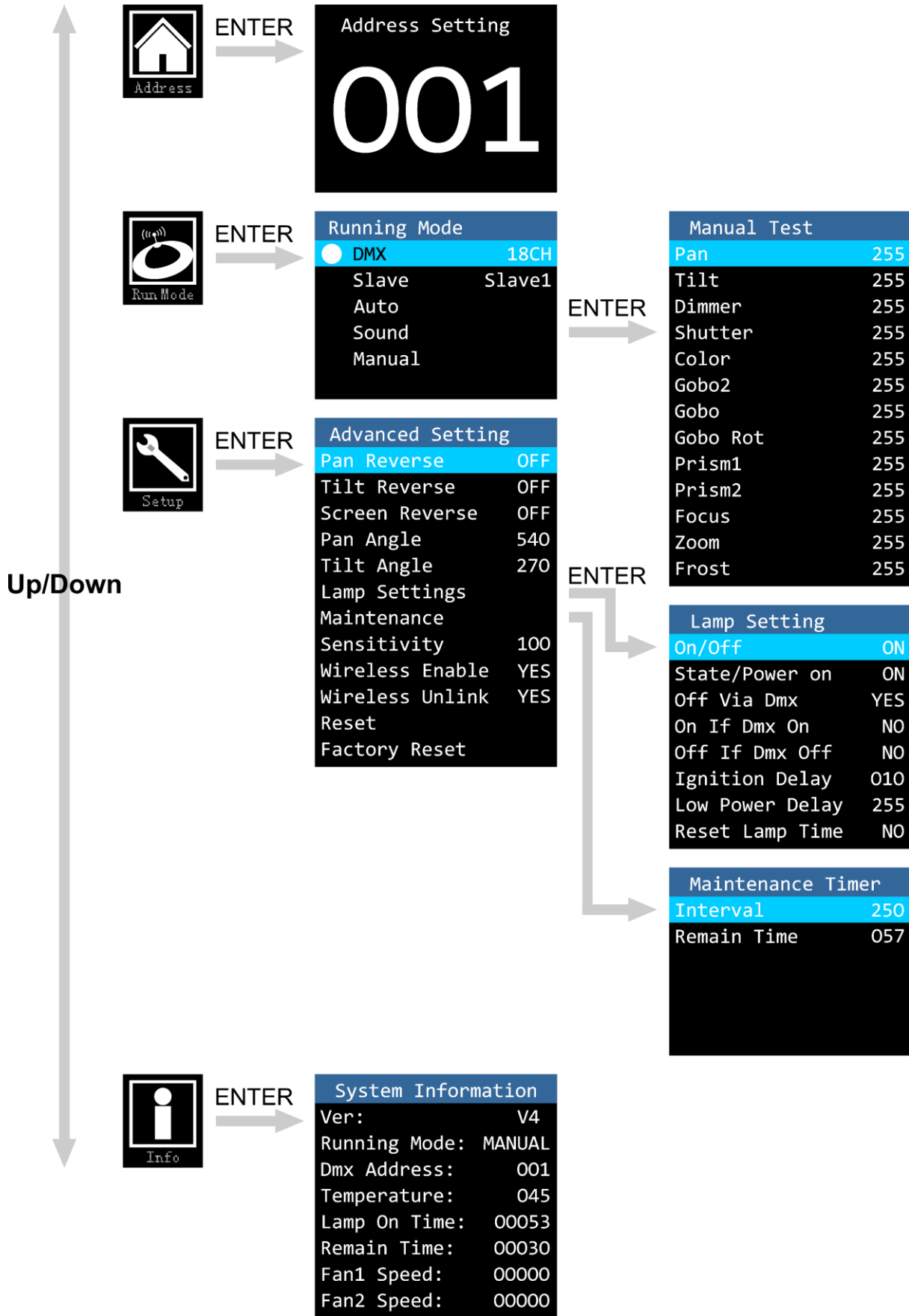

6.6. Main Menu Options



DMX Address



DMX mode / Slave / Auto / Sound / Manual



Pan Reverse / Tilt Reverse / Screen Reverse / Pan Angle / Tilt Angle / Lamp Settings / Maintenance / Sensitivity / Wireless Enable / Wireless Unlink / Reset / Factory Reset



System Information

6.6.1. DMX Address

In this menu you can set the DMX address.



- 01) While in the main menu, press the **UP/DOWN** buttons to select
- 02) Press the **ENTER** button to confirm. The adjustment range is 001–512. See **6.6.2.1 DMX** on page 23 for more information about how to activate the desired channel mode.
- 03) Press the **UP/DOWN** buttons to select the required address.
- 04) Press the **ENTER** button to confirm the address.

6.6.2. Built-in Programs Mode

In this menu you can set the DMX channel mode, slave mode, auto programs, sound-controlled mode and manual operation.



- 01) While in the main menu, press the **UP/DOWN** buttons to select
- 02) Press the **ENTER** button to open the menu.
- 03) Press the **UP/DOWN** buttons to select one of the 5 modes:

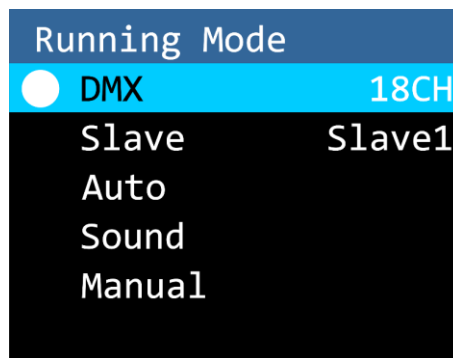

- 04) Press the **ENTER** button to open the desired submenu.

6.6.2.1. DMX

- 01) Press the **UP/DOWN** buttons to select one of the 2 DMX channel modes:
 - 14 channels
 - 18 channels
- 02) Press the **ENTER** button to confirm your choice.

6.6.2.2. Slave

- 01) Press the **UP/DOWN** buttons to set the device as the 1st, 2nd, 3rd or 4th slave device (Slave1–4).
- 02) Press the **ENTER** button to save changes.
- 03) The device is now operating in slave mode. It means that it will react the same as the master device. Each mode (Slave1–4) mirrors the master device in a different way.

6.6.2.3. Auto

The device will run the built-in auto show.

6.6.2.4. Sound

In this menu you can activate the sound-controlled operation mode. The device runs the auto program reacting to the beat of the music. See **6.6.3. Advanced Settings** on page 25 for information about the sensitivity settings of the built-in microphone.

6.6.2.5. Manual

01) The display shows:

Manual Test	
Pan	255
Tilt	255
Dimmer	255
Shutter	255
Color	255
Gobo2	255
Gobo	255
Gobo Rot	255
Prism1	255
Prism2	255
Focus	255
Zoom	255
Frost	255

02) Press the **UP/DOWN** buttons to choose one of the following 11 options:

- PAN
- TILT
- DIMMER (from low to high intensity)
- SHUTTER
- COLOR (color wheel)
- GOBO2 (static gobo wheel)
- GOBO (rotating gobo wheel)
- GOBO ROT (rotating gobo wheel rotation settings)
- PRISM1
- PRISM2
- FOCUS
- ZOOM
- FROST

03) Press the **ENTER** button to edit the desired option. The adjustment range for each option is between 0–255.

04) Press the **UP/DOWN** buttons to set the value.

05) Press the **ENTER** button to save changes.

The options from step 2 correspond with the functions described in the DMX charts. See **6.7. DMX Channels** on page 28 for more information.

6.6.3. Advanced Settings

In this menu you can adjust the advanced settings.



- 01) While in the main menu, press the **UP/DOWN** buttons to select
 02) Press the **ENTER** button to open the menu. The display shows:

Advanced Setting	
Pan Reverse	OFF
Tilt Reverse	OFF
Screen Reverse	OFF
Pan Angle	540
Tilt Angle	270
Lamp Settings	
Maintenance	
Sensitivity	100
Wireless Enable	YES
Wireless Unlink	YES
Reset	
Factory Reset	

- 03) Press the **UP/DOWN** buttons to choose one of the following 12 options:
- PAN REVERSE Pan reverse (ON/OFF)
 - TILT REVERSE Tilt reverse (ON/OFF)
 - SCREEN REVERSE Screen reverse (ON/OFF)
 - PAN ANGLE Pan angle settings (180°/360°/540°)
 - TILT ANGLE Tilt angle settings (90°/180°/270°)
 - LAMP SETTINGS See **6.6.3.1. Lamp Settings** on page 26 for more information.
 - MAINTENANCE See **6.6.3.2. Maintenance** on page 26 for more information.
 - SENSITIVITY Built-in microphone sensitivity (1–100, from low to high sensitivity)
 - WIRELESS ENABLE Activate/deactivate wireless DMX.
 - WIRELESS UNLINK Unlink wireless devices.
 - RESET Choose this option to reset the device's functions.
 - FACTORY RESET Choose this option to restore default factory settings.
- 04) Press the **ENTER** button to edit the desired option.
 05) Press the **UP/DOWN** buttons to set the value/change settings.
 06) Press the **ENTER** button to save changes/confirm your choice.

Note: The wireless DMX module is not installed. For this reason, wireless DMX will not function. Contact your Highlite International dealer for more information about the installation of the wireless DMX module.

6.6.3.1. Lamp Settings

In this menu you can set the lamp's behavior and reset the lamp's time counter.

Lamp Setting	
On/Off	ON
State/Power on	ON
Off Via Dmx	YES
On If Dmx On	NO
Off If Dmx Off	NO
Ignition Delay	010
Low Power Delay	255
Reset Lamp Time	NO

- 01) Press the **UP/DOWN** buttons to toggle between the following options:
- ON/OFF Turn the lamp on and off
 - STATE/POWER ON The lamp is on or off upon start-up (ON/OFF)
 - OFF VIA DMX Set the dimmer via DMX (YES/NO)
 - ON IF DMX ON When the device receives DMX, the lamp is on (YES/NO)
 - OFF IF DMX OFF When the device does not receive DMX, the lamp is off (YES/NO)
 - IGNITION DELAY Number of seconds after start-up before the lamp turns on (0-255)
 - LOW POWER DELAY Number of seconds after start-up before the device calibrates its gobos and pan/tilt motors, 0-255)
 - RESET LAMP TIME (YES/NO)
- 02) Press the **ENTER** button to edit the desired option.
- 03) Press the **UP/DOWN** buttons to set the value.
- 04) Press the **ENTER** button to save changes.

6.6.3.2. Maintenance

Maintenance Timer	
Interval	250
Remain Time	057

- 01) Press the **UP/DOWN** buttons to toggle between the following options:
- INTERVAL Number of hours after which the device should undergo a safety check (10-250)
 - REMAIN TIME Reset the internal maintenance clock after each safety check, (NO/RESET)
- 02) Press the **ENTER** button to edit the desired option.
- 03) Press the **UP/DOWN** buttons to set the value.
- 04) Press the **ENTER** button to save changes.

6.6.4. System Information

In this menu you can see the current software version, currently active mode, DMX starting address, temperature, Lamp On Time (lamp's operating hours), Remain Time (time after which a safety check should take place) and fan speed (1 and 2).



- 01) While in the main menu, press the **UP/DOWN** buttons to select
- 02) Press the **ENTER** button to open the menu and view the parameters.
- 03) Press the **UP/DOWN** buttons to view the fan speed.

System Information	
Ver:	V4
Running Mode:	MANUAL
Dmx Address:	001
Temperature:	045
Lamp On Time:	00053
Remain Time:	00030
Fan1 Speed:	00000
Fan2 Speed:	00000





6.7. DMX Channels



CAUTION
Possible damage to the lamp

Do not turn off the device if the lamp was on for shorter than 5 minutes. It will cause mercury build-up on the lamp's electric poles and it will not be possible to turn the lamp on. See **7. Troubleshooting** on page 36 for more information.

6.7.1. 14 Channels, 18 Channels

14 CH	18 CH	Function	Value	Setting	
1	1	Pan	000–255	Pan adjustment 0°–540°	
2	2	Tilt	000–255	Tilt adjustment 0°–270°	
	3	Pan, Fine	000–255	Pan adjustment, 16-bit	
	4	Tilt, Fine	000–255	Tilt adjustment, 16-bit	
	5	Pan/Tilt speed	000–255	Speed adjustment of the pan/tilt, from fast to slow	
3	6	Master Dimmer	000–255	From low to high intensity (0–100 %)	
4	7	Strobe	000–007	Output blackout	
			008–015	Open	
			016–131	Synchronized strobe, from low to high frequency	
			132–167	Fast close, slow open; from low to high frequency	
			168–203	Slow close, fast open; from low to high frequency	
			204–239	Pulse strobe, from low to high frequency	
			240–250	Random strobe, from slow to fast	
5	8	Color Wheel	251–255	Open	
			000–004	Open	
			005–008	Color 1 (Red)	
			009–012	Color 2 (Dark Yellow)	
			013–016	Color 3 (Green)	
			017–020	Color 4 (Cyan)	
			021–024	Color 5 (Rose Red)	
			025–028	Color 6 (Orange)	
			029–032	Color 7 (Blue)	
			033–036	Color 8 (Magenta)	
			037–040	Color 9 (Green)	
			041–044	Color 10 (CTO)	
			045–048	Color 11 (CTB)	
			049–059	Color 12 (Congo)	
			060–072	Split colors (Open/Red)	
			073–082	Split colors (Red/Dark Yellow)	
			083–092	Split colors (Dark Yellow/Green)	
			093–102	Split colors (Green/Cyan)	
			103–111	Split colors (Cyan/Rose Red)	
			112–121	Split colors (Rose Red/Orange)	
			122–131	Split colors (Orange/Blue)	
			132–141	Split colors (Blue/Magenta)	
			142–150	Split colors (Magenta/Green)	
			151–160	Split colors (Green/CTO)	
			161–170	Split colors (CTO/CTB)	
			171–180	Split colors (CTB/Congo)	
			181–187	Split colors (Congo/Open)	
			188–219	Color scroll counter-clockwise, from fast to slow	

14 CH	18 CH	Function	Value	Setting
			220–223	Stop
			224–255	Color scroll clockwise, from slow to fast



Open



Gobo 1



Gobo 2



Gobo 3



Gobo 4



Gobo 5



Gobo 6



Gobo 7



Gobo 8



Gobo 9



Gobo 10



Gobo 11

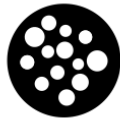

Gobo 12



Gobo 13



Gobo 14



Gobo 15



Gobo 16

6	9	Static Gobo Wheel	000–003	Open
			004–007	Gobo 1
			008–011	Gobo 2
			012–015	Gobo 3
			016–019	Gobo 4
			020–023	Gobo 5
			024–027	Gobo 6
			028–031	Gobo 7
			032–035	Gobo 8
			036–039	Gobo 9
			040–043	Gobo 10
			044–047	Gobo 11
			048–051	Gobo 12
			052–055	Gobo 13
			056–059	Gobo 14
			060–063	Gobo 15
			064–071	Gobo 16
			072–075	Gobo 16 shaking, from slow to fast
			076–079	Gobo 15 shaking, from slow to fast
			080–083	Gobo 14 shaking, from slow to fast
			084–087	Gobo 13 shaking, from slow to fast
			088–091	Gobo 12 shaking, from slow to fast
			092–095	Gobo 11 shaking, from slow to fast
			096–099	Gobo 10 shaking, from slow to fast
			100–103	Gobo 9 shaking, from slow to fast
			104–107	Gobo 8 shaking, from slow to fast
			108–111	Gobo 7 shaking, from slow to fast
			112–115	Gobo 6 shaking, from slow to fast
			116–119	Gobo 5 shaking, from slow to fast
			120–123	Gobo 4 shaking, from slow to fast
			124–127	Gobo 3 shaking, from slow to fast
			128–131	Gobo 2 shaking, from slow to fast
			132–135	Gobo 1 shaking, from slow to fast
136–143	Open gobo			
144–199	Clockwise gobo effect, from slow to fast			
200–255	Counter-clockwise gobo effect, from slow to fast			



7	10	Rotating Gobo Wheel	000-005	Open 1
			006-011	Open 2
			012-017	Gobo 1
			018-023	Gobo 2
			024-029	Gobo 3
			030-035	Gobo 4
			036-041	Gobo 5
			042-047	Gobo 6
			048-053	Gobo 7
			054-063	Gobo 8
			064-069	Gobo 8 shaking, from slow to fast
			070-075	Gobo 7 shaking, from slow to fast
			076-081	Gobo 6 shaking, from slow to fast
			082-087	Gobo 5 shaking, from slow to fast
			088-093	Gobo 4 shaking, from slow to fast
			094-099	Gobo 3 shaking, from slow to fast
			100-105	Gobo 2 shaking, from slow to fast
			106-111	Gobo 1 shaking, from slow to fast
			112-127	Open 1
			128-191	Clockwise gobo effect, from slow to fast
192-255	Counter-clockwise gobo effect, from slow to fast			
8	11	Gobo Rotation	000-063	Gobo indexing
			064-145	Clockwise rotation, from slow to fast
			146-149	Stop
			150-231	Counter-clockwise rotation, from slow to fast
			232-255	Gobo bouncing, from quick short bounce to longer rotation bounce
9	12	Prism 1	000-007	No function
			008-012	24-facet prism (circular)
			013-127	Clockwise 24-facet prism rotation, from slow to fast
			128-132	Stop
			133-247	Counter-clockwise 24-facet prism rotation, from slow to fast
			248-255	Stop
10	13	Prism 2	000-007	No function
			008-012	8-facet prism (circular)
			013-127	Clockwise 8-facet prism rotation, from slow to fast
			128-132	Stop
			133-247	Counter-clockwise 8-facet prism rotation, from slow to fast
			248-255	Stop

11	14	Frost	000–255	0–100 %
12	15	Focus	000–255	0–100 %
13	16	Zoom	000–255	From big to small (0–100 %)
	17	Functions	000–007	No function
			008–015	Blackout during Pan/Tilt + Pan Fine /Tilt Fine movement
			016–023	Blackout during color wheel movement
			024–031	Blackout during gobo wheel (Static+Rotating) movement
			032–039	Blackout during Pan/Tilt + Pan Fine /Tilt Fine /color wheel movement
			040–047	Blackout during Pan/Tilt + Pan Fine /Tilt Fine /gobo wheel (Static+Rotating) movement
			048–055	Blackout during Pan/Tilt + Pan Fine /Tilt Fine /color wheel movement/gobo wheel (Static+Rotating) movement
			056–087	No function
			088–095	Lamp on
			096–103	Reset Pan after 5 seconds
			104–111	Reset Tilt after 5 seconds
			112–119	Color wheel reset after 5 seconds
			120–127	Gobo wheel (Static+Rotating) reset after 5 seconds
			128–135	Frost reset after 5 seconds
			136–143	Prism (24-facet and 8-facet) reset after 5 seconds
			144–151	Focus and zoom reset after 5 seconds
			152–159	Reset all
			160–231	No function
			232–239	Lamp off
			240–255	No function
14	18	Built-in programs	000–007	No Function
			008–023	Built-in program 1
			024–039	Built-in program 2
			040–055	Built-in program 3
			056–071	Built-in program 4
			072–087	Built-in program 5
			088–103	Built-in program 6
			104–119	Built-in program 7
			120–135	Built-in program 8
			136–151	Sound-controlled program 1
			152–167	Sound-controlled program 2
			168–183	Sound-controlled program 3
			184–199	Sound-controlled program 4
			200–215	Sound-controlled program 5
			216–231	Sound-controlled program 6
			232–247	Sound-controlled program 7
				248–255

Note:

- Make sure that the Master Dimmer and the Strobe channels are open in order to see the light output.
- Make sure that the lamp is on in order to see the light output.
- Use the prism overlay to combine the effects of Prism 1 and Prism 2.

6.8. Gobo Wheels and Color Wheel

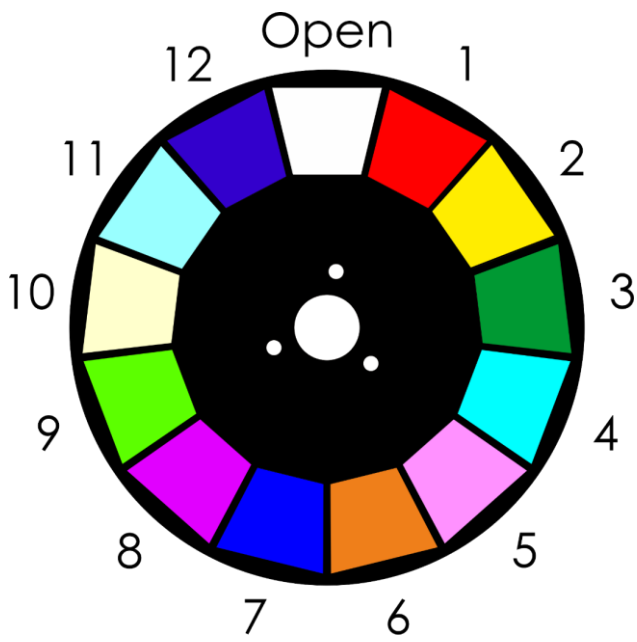

Color wheel

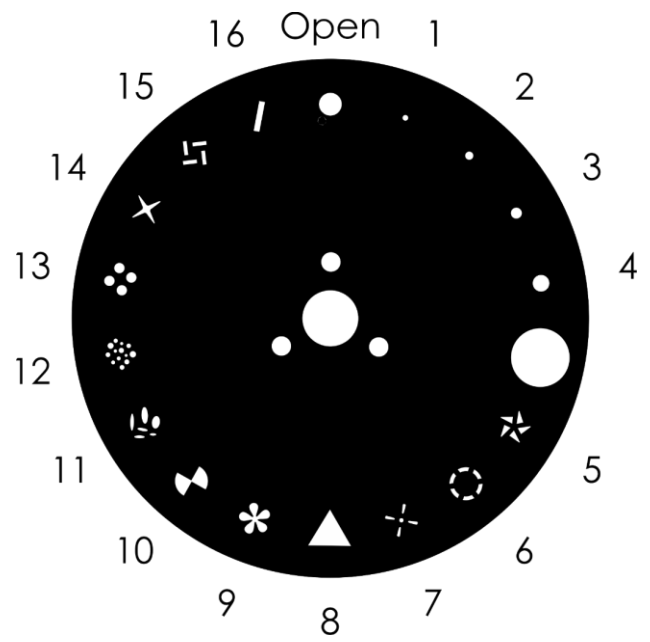

Static gobo wheel

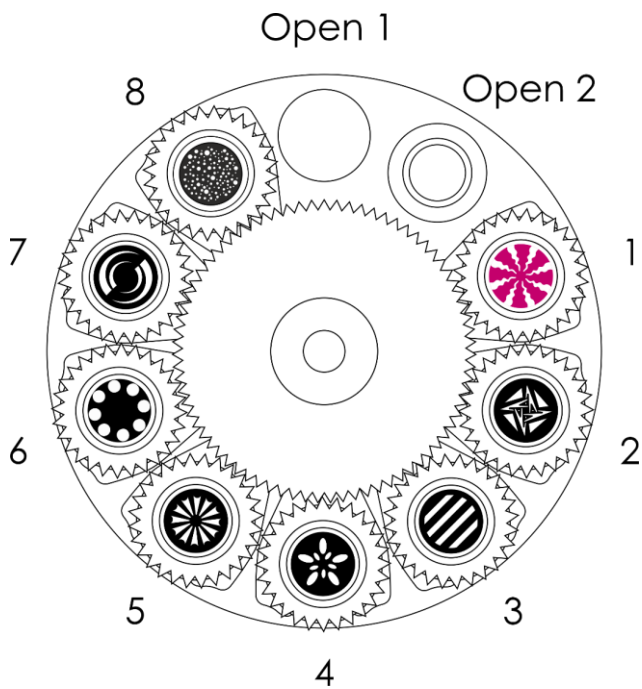

Rotating gobo wheel

Fig. 12

6.8.1. Replacing a Gobo From the Rotating Gobo Wheel



DANGER
Electric shock caused by dangerous voltage inside

There are areas within the device where dangerous touch voltage may be present.

- Disconnect the device from electrical power supply before service and maintenance, and when the device is not in use.
- Allow the device to cool down before opening the cover.
- Use for replacement only gobos that match the specifications below. Using custom gobos that do not match those specifications may result in damage to the device. Any damage to the device as a result of using a custom gobo is not covered under warranty.
- Do not touch the glass gobo with bare fingers to avoid leaving fingerprints. Handle the gobo only by the gobo carrier, or wear protective gloves. If you touch the glass, clean with a soft lint-free cloth and rubbing alcohol.

To replace a rotating gobo, follow the steps below:

- 01) Disconnect the device from the mains and allow it to cool completely (20 minutes).
- 02) Set the device in horizontal position with the lens facing forward.
- 03) Loosen the 4 screws on the head cover, as shown in Fig. 13.

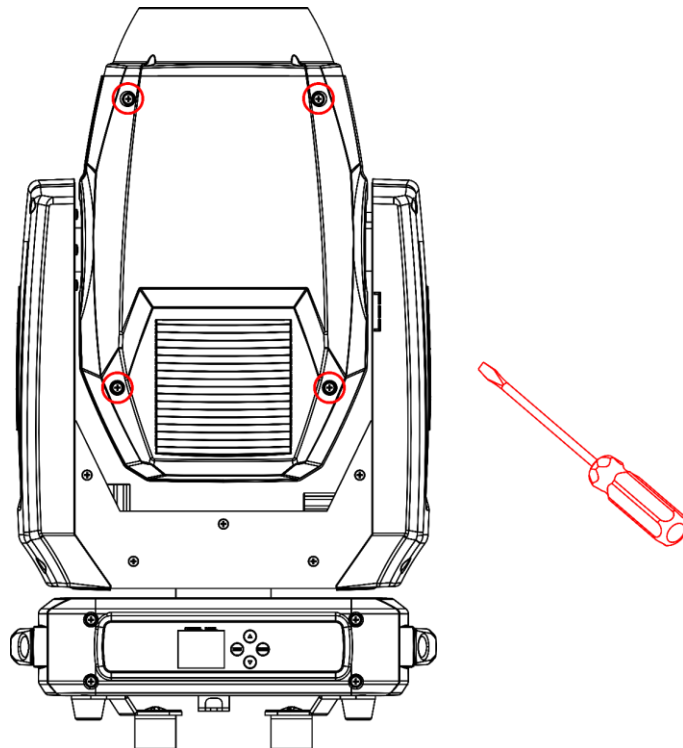

Fig. 13

- 04) Carefully remove the head cover from the housing to get access to the rotating gobo wheel.
- 05) Turn the rotating gobo wheel by hand until you reach the gobo which you want to replace.

- 06) Gently lift the gobo holder a bit up and pull it out from the rotating gobo wheel, as shown in Fig. 14 and Fig. 15.

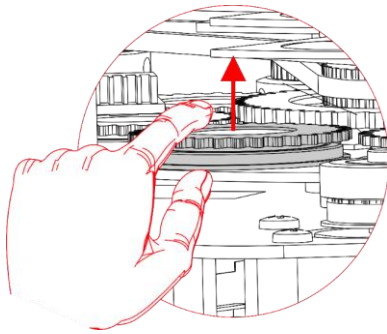

Fig. 14

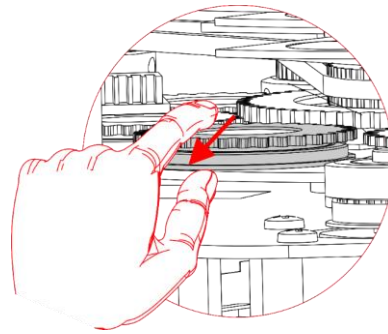

Fig. 15

- 07) Very carefully remove the retainer spring from the gobo holder with a small flathead screwdriver or similar. Please note, that high temperature silicone sealant is applied to the retainer spring.
 08) Take the gobo out of the gobo holder. Do not touch the gobo with bare fingers.
 09) Insert the new gobo in the gobo holder. See **6.8.3. Glass Gobo Orientation** on page 35 for more information.
 10) Carefully insert the retainer spring with the narrow end against the gobo (see Fig. 16). To identify the narrow end, press the spring flat: the narrow end is on the inside.

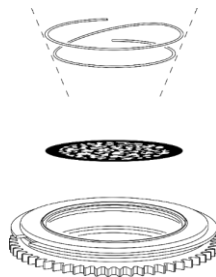

Fig. 16

- 11) Gently press the retainer spring as flat as possible against the back of the gobo using a small flathead screwdriver or similar.
 12) Place the gobo holder back into the gobo assembly and snap it into position.
 13) Replace the head cover and tighten all 4 screws.

6.8.2. Gobo Size

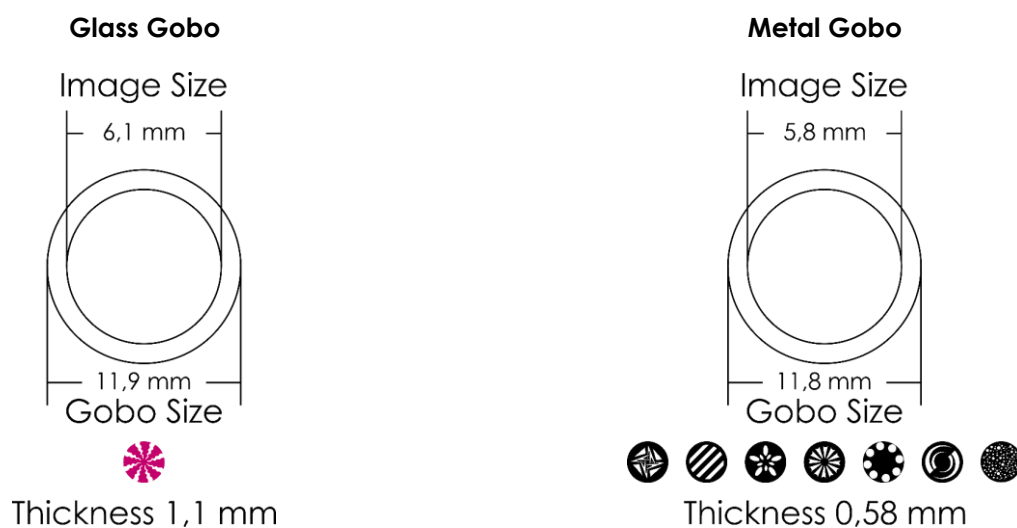

Fig. 17

6.8.3. Glass Gobo Orientation

Coated glass gobos are inserted with the coating against the rim of the holder (away from the spring). Textured gobos are inserted with the smooth side against the spring. This provides the best results when combining rotating gobos.



When an object is held up to the coated side, there is no space between the object and its reflection. The back edge of the gobo cannot be seen when looking through the coated side.

When an object is held up to the uncoated side, there is a space between the object and its reflection. The back edge of the gobo can be seen when looking through the uncoated side.

6.9. Lamp

The device is equipped with an Ushio NSL300 discharge lamp (product code 81019).



Attention
Lamp can stop working if used improperly

Do not turn off the device if the lamp was on for shorter than 5 minutes. It will cause mercury build-up on the lamp's electric poles and it will not be possible to turn the lamp on. See **7. Troubleshooting** on page 36 for more information.

7. Troubleshooting

This troubleshooting guide contains solutions to problems which can be carried out by an ordinary person. The device does not contain user-serviceable parts.

Unauthorized modifications to the device will render the warranty void. Such modifications may result in injuries and material damage.

Refer servicing to instructed or skilled persons. Contact your Highlite International dealer in case the solution is not described in the table.

Problem	Probable cause(s)	Solution
The device does not function at all	No power to the device	<ul style="list-style-type: none"> Check if power is switched on and cables are plugged in
	Main fuse is blown	<ul style="list-style-type: none"> Replace the fuse. See 8.3.1. Replacing the Fuse on page 38
The device responds erratically	The factory settings of the device are changed	<ul style="list-style-type: none"> Reset the device's parameters to the default factory settings. See 6.6.3. Advanced Settings on page 25
The device does not respond to DMX control	The controller is not connected	<ul style="list-style-type: none"> Connect the controller
	The signal is reversed. The 3-pin DMX OUT of the controller does not match the DMX IN of the device	<ul style="list-style-type: none"> Install a phase-reversing cable between the controller and the device
	The controller is defective	<ul style="list-style-type: none"> Try using another controller
The device responds erratically to DMX control	Bad data link connection	<ul style="list-style-type: none"> Examine connections and cables. Correct poor connections. Repair or replace damaged cables
	The data link is not terminated with a 120 Ω termination plug	<ul style="list-style-type: none"> Insert a termination plug in the DMX OUT connector of the last device on the link
	Incorrect addressing	<ul style="list-style-type: none"> Check address settings and correct, if necessary
	In case of a setup with multiple devices, one of the devices is defective and disturbs data transmission on the link	<ul style="list-style-type: none"> To find out the defective device, bypass one device at a time until normal operation is restored
No light or lamp cuts out intermittently	Lamp is damaged	<ul style="list-style-type: none"> Disconnect the device and replace the lamp. See 8.3.2. Replacing the Lamp on page 39
	The power supply settings do not match local AC voltage and frequency	<ul style="list-style-type: none"> Disconnect the device. Check the settings and correct, if necessary
	There is a mercury build-up on the lamp's electric poles	<ul style="list-style-type: none"> Remove the lamp (see 8.3.2. Replacing the Lamp on page 39) and slightly shake the 2 electric poles in order to remove the mercury build-up

8. Maintenance

8.1. Safety Instructions for Maintenance



DANGER
Electric shock caused by dangerous voltage inside

Disconnect power supply before servicing or cleaning.



WARNING
Risk of burns due to hot surface

Allow the device to cool down for at least 20 minutes before servicing or cleaning.

8.2. Preventive Maintenance



Attention
Before each use, examine the device visually for any defects.

Make sure that:

- All screws used for installing the device or parts of the device are tightly fastened and are not corroded.
- The safety devices are not damaged.
- There are no deformations on housings, fixations and installation points.
- The lens is not cracked or damaged.
- The power cables are not damaged and do not show any material fatigue.

8.2.1. Basic Cleaning Instructions

The external lens of the device must be cleaned periodically in order to optimize the light output. The cleaning schedule depends on the conditions at the site where the device is installed. When smoke or fog machines are used at the site, the device will need more frequent cleaning. On the other hand, if the device is installed in well-ventilated area, it will need less frequent cleaning. To establish a cleaning schedule, examine the device at regular intervals during the first 100 hours of operation.

To clean the device, follow the steps below:

- 01) Disconnect the device from the electrical power supply.
- 02) Allow the device to cool down for at least 20 minutes.
- 03) Remove the dust collected on the external surface with dry compressed air and a soft brush.
- 04) Clean the lens with a damp cloth. Use a mild detergent solution.
- 05) Dry the lens carefully with a lint-free cloth.
- 06) Clean the DMX and other connections with a damp cloth.



Attention

- Do not immerse the device in liquid.
- Do not use alcohol or solvents.
- Make sure that the connections are fully dry before connecting the device to the power supply and to other devices.

8.3. Corrective Maintenance

The device does not contain user-serviceable parts. Do not open the device and do not modify the device.

Refer repairs and servicing to instructed or skilled persons. Contact your Highlite International dealer for more information.

8.3.1. Replacing the Fuse



DANGER Electric shock caused by short-circuit

- Do not bypass the thermostatic switch or fuses.
- For replacement use fuses of the same type and rating only.

Power surges, short-circuit or incorrect electrical power supply may cause a fuse to burn out. If the fuse burns out, the device will not function anymore. If this happens, follow the steps below.

- 01) Disconnect the device from the electrical power supply.
- 02) Allow the device to cool down for at least 20 minutes.
- 03) Loosen the fuse cover with a screwdriver and remove the fuse holder.
- 04) If the fuse is brown or unclear, it is burned out. Remove the old fuse.
- 05) Insert a new fuse in the fuse holder. Make sure that the type and the rating of the replacement fuse are the same as the ones specified on the information label of the product.
- 06) Replace the fuse holder in the opening and tighten the fuse cover.

8.3.2. Replacing the Lamp



Important

Read and follow the instructions in this user manual, as well as in the user manual of the replacement lamp, before replacing the lamp.

The manufacturer will not accept liability for any resulting damages caused by the non-observance of the respective manuals.



Attention

Lamp can spontaneously explode

A hot discharge lamp is under high pressure and can therefore spontaneously explode. The risk increases with the age, temperature and improper handling of the lamp.

If the lamp breaks, special safety precautions must be taken as mercury is released. Evacuate the area immediately and ventilate it.

- Replace the lamp if it has become damaged or thermally deformed.
- Do not install lamps with a higher wattage.
- Read the safety instructions that are included with the lamp before replacing the lamp.
- Let the lamp cool down for 20 minutes, before replacing the lamp.
- Do not touch the lamp with bare fingers. Oil on hands shortens the lamp's lifespan. If you touched the lamp, clean with a soft lint-free cloth and rubbing alcohol.

To replace the lamp, follow the steps below:

- 01) Disconnect the device from the electrical power supply and allow it to cool down for at least 20 minutes.
- 02) Loosen the 8 fasteners on the housing and remove both covers (Fig. 18).

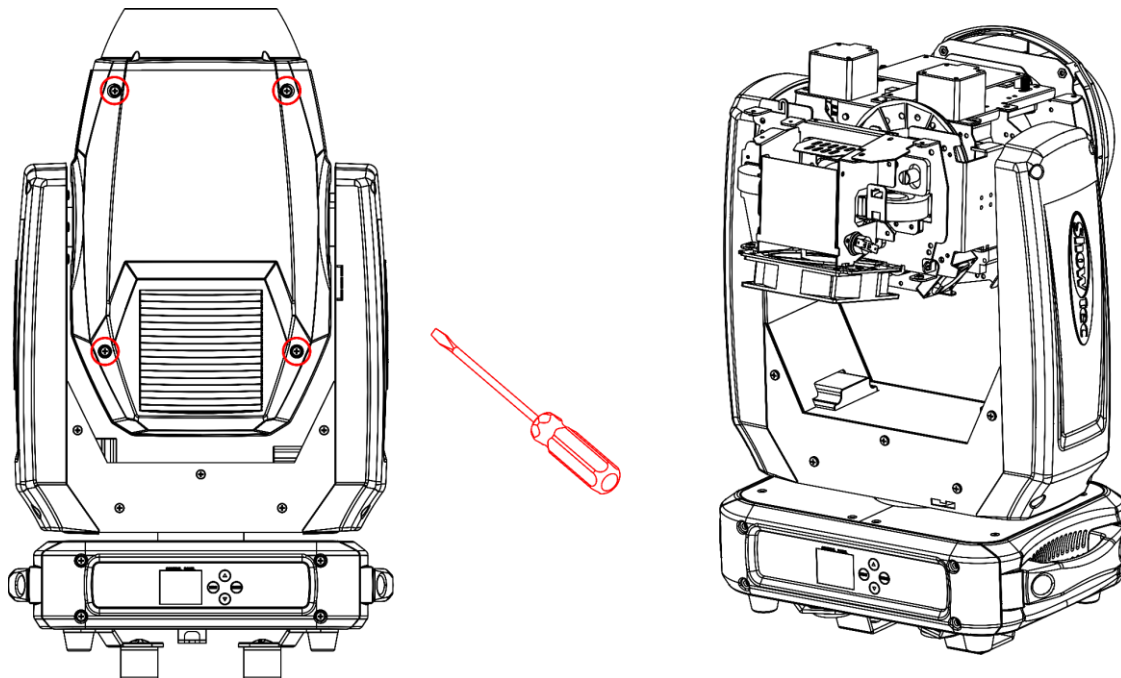

Fig. 18

- 03) Open the lamp housing (Fig. 19).
- 04) Disconnect the 2 wires from the lamp terminals (Fig. 20).

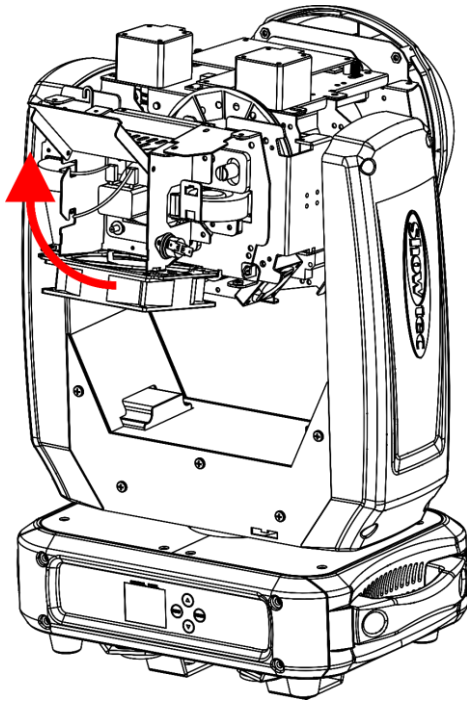

Fig. 19

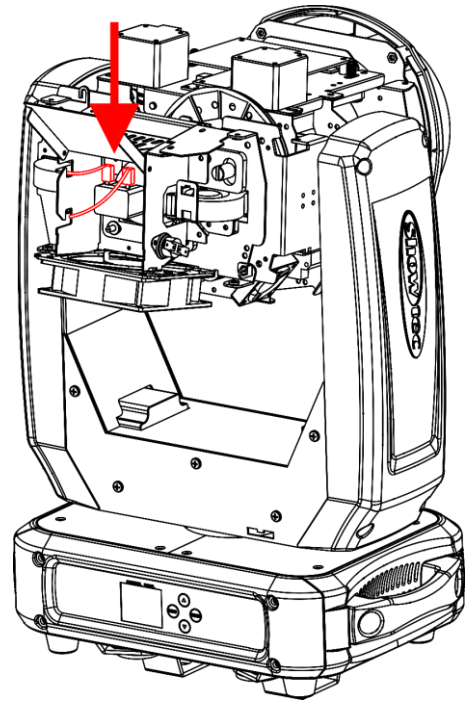

Fig. 20

- 05) Push the lamp carefully to the right against the 2 springs on the right side (Fig. 21).
- 06) Roll the lamp carefully out of the device and remove it (Fig. 22).

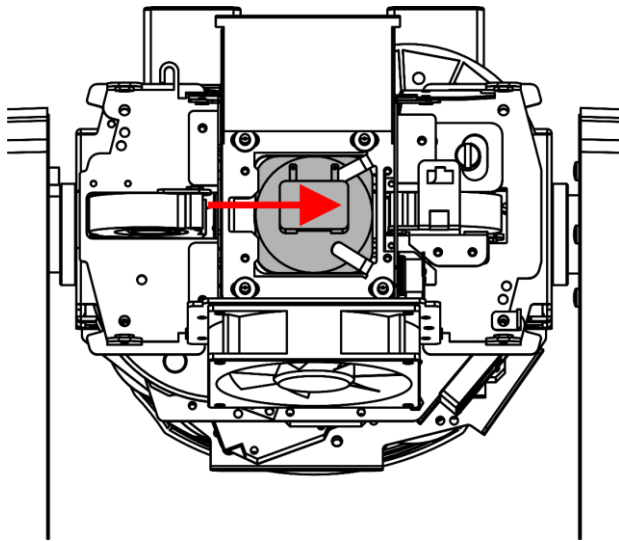

Fig. 21

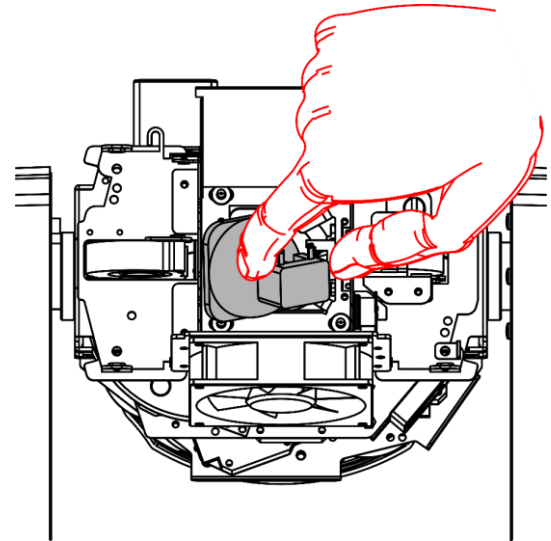

Fig. 22

- 07) Take the new lamp (hold it by the base).
- 08) Carefully put the lamp under the 2 springs.
- 09) Connect the 2 wires to the lamp terminals.
- 10) Put the covers in position and tighten the 8 fasteners on the housing.

Note: When a new lamp is installed, it is recommended to reset the lamp operating hours counter. See **6.6.3.1. Lamp Settings** on page 26. You can view total operating hours of the lamp (Lamp on Time) in **6.6.4. System Information** submenu (see page 27).

8.3.3. Adjusting the Lamp

The lamp position is set in the factory. As lamps differ from manufacturer to manufacturer, it may be necessary to readjust their position. If the hotspot is not in the center of the projection of the light beam, calibrate it on a horizontal plane (wall).

- 01) Set the device in horizontal position with the lens facing forward.
- 02) Loosen the 8 fasteners on the housing and remove both covers (Fig. 23).
- 03) Using a flat-head screwdriver turn the adjustment screw clockwise to move the hotspot to the left and counter-clockwise to move it to the right (Fig. 24).

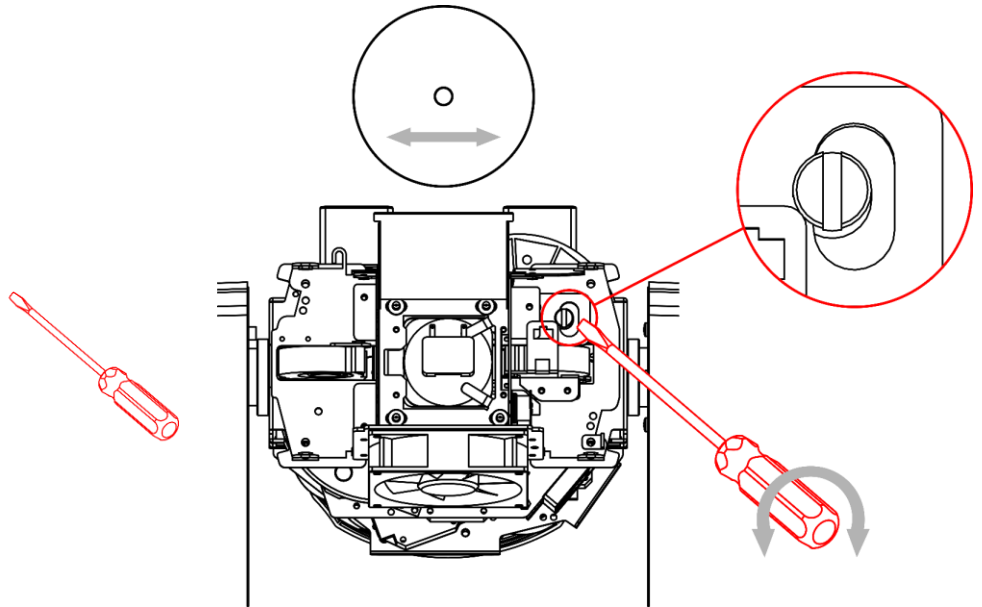
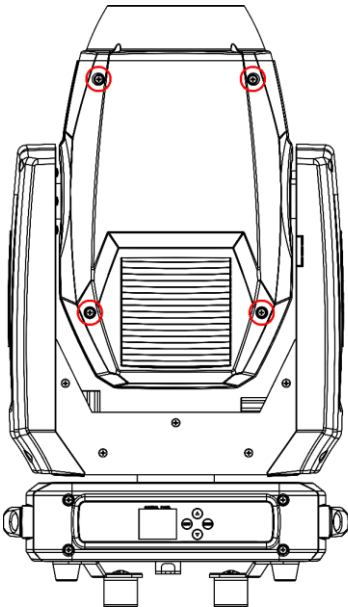

Fig. 23

Fig. 24

- 04) Put the covers in position and tighten the 8 fasteners on the housing.

9. Deinstallation, Transportation and Storage

9.1. Instructions for Deinstallation



WARNING

Incorrect deinstallation can cause serious injuries and damage of property.

- Let the device cool down before dismounting.
- Disconnect power supply before deinstallation.
- Always observe the national and site-specific regulations during deinstallation and derigging of the device.
- Wear personal protective equipment in compliance with the national and site-specific regulations.

9.2. Instructions for Transportation

- Use the original packaging to transport the device, if possible.
- Always observe the handling instructions printed on the outer carton box, for example: "Handle with care", "This side up", "Fragile".

9.3. Storage

- Clean the device before storing. Follow the cleaning instructions in chapter **8.2.1. Basic Cleaning Instructions** on page 37.
- Store the device in the original packaging, if possible.

10. Disposal

Correct disposal of this product



Waste Electrical and Electronic Equipment

This symbol on the product, its packaging or documents indicates that the product shall not be treated as household waste. Dispose of this product by handing it to the respective collection point for recycling of electrical and electronic equipment. This is to avoid environmental damage or personal injury due to uncontrolled waste disposal. For more detailed information about recycling of this product contact the local authorities or the authorized dealer.

11. Approval



Check the respective product page on the website of Highlite International (www.highlite.com) for an available declaration of conformity.



©2021 Showtec