

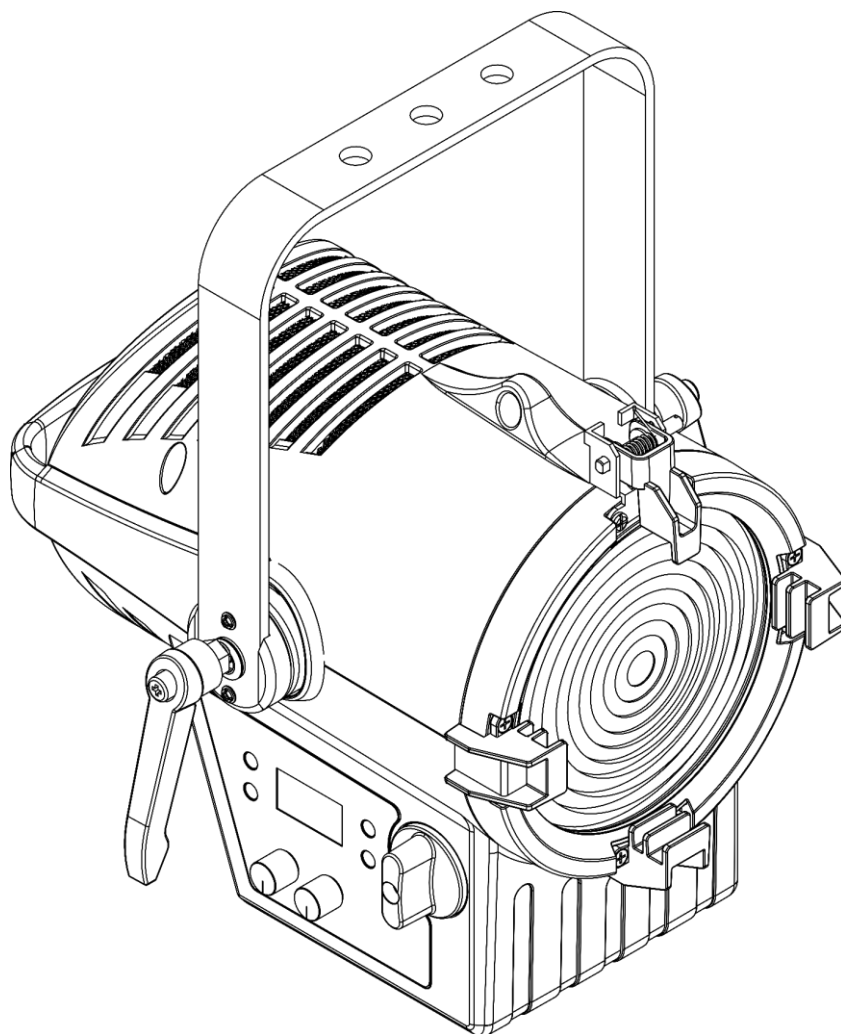

## USER MANUAL



ENGLISH

# Performer 1500 Fresnel Q6 V3

Product code: 33130

## Preface

---

Thank you for purchasing this Showtec product.

The purpose of this user manual is to provide instructions for the correct and safe use of this product.

Keep the user manual for future reference as it is an integral part of the product. The user manual shall be stored at an easily accessible location.

This user manual contains information concerning:

- Safety instructions
- Intended and non-intended use of the device
- Installation and operation of the device
- Maintenance procedures
- Troubleshooting
- Transport, storage and disposal of the device

Non-observance of the instructions in this user manual may result in serious injuries and damage of property.

©2022 Showtec. All rights reserved.

No part of this document may be copied, published or otherwise reproduced without the prior written consent of Highlite International.

Design and product specifications are subject to change without prior notice.

For the latest version of this document, please visit our website [www.highlite.com](http://www.highlite.com) or contact us at [service@highlite.com](mailto:service@highlite.com).

Highlite International and its authorized service providers are not liable for any injury, damage, direct or indirect loss, consequential or economic loss or any other loss arising from the use of, or inability to use or reliance on the information contained in this document.

## Table of contents

<b>1. Introduction.....</b>	<b>4</b>
1.1. Before Using the Product .....	4
1.2. Intended Use .....	4
1.3. Product Lifespan.....	4
1.4. LEDs Lifespan .....	4
1.5. Text Conventions .....	4
1.6. Symbols and Signal Words.....	5
1.7. Symbols on the Information Label .....	5
<b>2. Safety .....</b>	<b>6</b>
2.1. Warnings and Safety Instructions .....	6
2.2. Requirements for the User.....	8
<b>3. Description of the Device .....</b>	<b>9</b>
3.1. Front View .....	9
3.2. Back View .....	10
3.3. Product Specifications .....	11
3.4. Optional Accessories.....	12
3.5. Dimensions.....	12
<b>4. Installation .....</b>	<b>13</b>
4.1. Safety Instructions for Installation .....	13
4.2. Personal Protective Equipment .....	13
4.3. Installation Site Requirements .....	13
4.4. Rigging .....	13
4.4.1. Angle Adjustment.....	15
4.4.2. Zoom Adjustment .....	15
4.5. Barndoor Installation.....	16
4.6. Connecting to Power Supply.....	17
4.7. Power Linking of Multiple Devices.....	17
<b>5. Setup .....</b>	<b>18</b>
5.1. Warnings and Precautions .....	18
5.2. Stand-alone Setup .....	18
5.3. DMX Connection.....	18
5.3.1. DMX-512 Protocol.....	18
5.3.2. DMX Cables.....	19
5.3.3. Master/Slave Setup .....	19
5.3.4. DMX Linking.....	20
5.3.5. DMX Addressing.....	20
<b>6. Operation .....</b>	<b>21</b>
6.1. Safety Instructions for Operation .....	21
6.2. Control Modes .....	21
6.3. Control Panel .....	22
6.4. Start-up.....	22
6.5. Menu Overview .....	23
6.6. Main Menu Options .....	26
6.6.1. Knob Mode .....	26
6.6.2. Static .....	26
6.6.3. DMX Address .....	27
6.6.4. Run Mode.....	27
6.6.5. Personality (DMX Channel Modes) .....	27
6.6.6. Preset Color.....	27
6.6.7. Auto Programs .....	28
6.6.8. Edit.....	28
6.6.8.1. Upload.....	29
6.6.9. Settings.....	30

- 6.6.9.1. Reset .....30
- 6.6.9.2. Dimmer .....30
- 6.6.9.3. DMX Error.....30
- 6.6.9.4. PWM Rate .....31
- 6.6.9.5. Performance .....31
- 6.6.9.6. Disp Key (Display Lock) .....31
- 6.6.9.7. Disp Time (Display Time) .....31
- 6.6.10. Information .....31
  - 6.6.10.1. Fixture Hours.....31
  - 6.6.10.2. Version .....32
  - 6.6.10.3. RDM.....32
- 6.6.11. CCT (Correlated Color Temperature Control).....32
- 6.6.12. Preset Color .....33
- 6.7. DMX Channels .....34
  - 6.7.1. 3 Channels, 8 Channels, 13 Channels, 20 Channels .....34
  - 6.7.2. 7 Channels .....36
  - 6.7.3. 10 Channels .....37
- 6.8. Supported RDM PIDs (Parameter IDs) .....39
- 7. Troubleshooting .....40**
- 8. Maintenance .....41**
  - 8.1. Safety Instructions for Maintenance .....41
  - 8.2. Preventive Maintenance .....41
    - 8.2.1. Basic Cleaning Instructions .....42
  - 8.3. Corrective Maintenance .....42
    - 8.3.1. Replacing the Fuse.....42
- 9. Deinstallation, Transportation and Storage .....43**
  - 9.1. Instructions for Deinstallation.....43
  - 9.2. Instructions for Transportation .....43
  - 9.3. Storage .....43
- 10. Disposal .....43**
- 11. Approval.....43**

## 1. Introduction

### 1.1. Before Using the Product



**Important**

**Read and follow the instructions in this user manual before installing, operating or servicing this product.**

The manufacturer will not accept liability for any resulting damages caused by the non-observance of this manual.

After unpacking, check the contents of the box. If any parts are missing or damaged, contact your Highlite International dealer.

Your shipment includes:

- Showtec Performer 1500 Fresnel Q6
- Schuko to True1 pro power cable (1,4 m)
- 1 x safety cable
- User manual

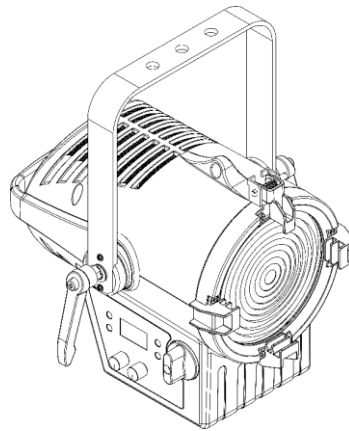

Fig. 01

### 1.2. Intended Use

This device is intended for professional use as a theater spot. It is suitable only for indoor installation. This device is not suitable for households and for general lighting.

Any other use, not mentioned under intended use, is regarded as non-intended and incorrect use.

### 1.3. Product Lifespan

This device is not designed for permanent operation. Disconnect the device from the electrical power supply when the device is not in operation. This will reduce the wear and will improve the device's lifespan.

### 1.4. LEDs Lifespan

The light output of the LEDs gradually decreases over time (lumen depreciation). High operating temperatures contribute to this process. You can extend the lifespan of the LEDs by providing adequate ventilation and operating the LEDs at the lowest possible brightness.

### 1.5. Text Conventions

Throughout the user manual the following text conventions are used:









- Buttons: All buttons are in bold lettering, for example "Press the **UP/DOWN** buttons"

- References: References to chapters and parts of the device are in bold lettering, for example: "Refer to **2. Safety**", "turn the **adjustment screw (02)**"
- 0–255: Defines a range of values
- Notes: **Note:** (in bold lettering) is followed by useful information or tips

## 1.6. Symbols and Signal Words

Safety notes and warnings are indicated throughout the user manual by safety signs.





Always follow the instructions provided in this user manual.

	<b>DANGER</b>	Indicates an imminently hazardous situation which, if not avoided, will result in death or serious injury.
	<b>WARNING</b>	Indicates a potentially hazardous situation which, if not avoided, could result in death or serious injury.
	<b>CAUTION</b>	Indicates a potentially hazardous situation, which, if not avoided, may result in minor or moderate injury.
	<b>Attention</b>	Indicates important information for the correct operation and use of the product.
	<b>Important</b>	Read and observe the instructions in this document.
	<b>Electrical hazard</b>	
	<b>Hot surface</b>	
	<b>Eye damage hazard</b>	
		Provides important information about the disposal of this product.

## 1.7. Symbols on the Information Label

This product is provided with an information label. The information label is located on the backside of the device.

The information label contains the following symbols:

	This device is designed for indoor use.
	This device shall not be treated as household waste.
	Replace any cracked protective shield.
	Minimum distance from lighted objects.
	Caution: Risk of electric shock. Disconnect input power before opening. This appliance must be earthed.

## 2. Safety



### Important

**Read and follow the instructions in this user manual before installing, operating or servicing this product.**

The manufacturer will not accept liability for any resulting damages caused by the non-observance of this manual.

### 2.1. Warnings and Safety Instructions



#### DANGER

**Danger for children**

For adult use only. The device must be installed beyond the reach of children.

- Do not leave various parts of the packaging (plastic bags, polystyrene foam, nails, etc.) within children's reach. Packaging material is a potential source of danger for children.



#### DANGER

**Electric shock caused by dangerous voltage inside**

There are areas within the device where dangerous touch voltage (> 120 V DC) may be present.

- Do not open the device or remove any covers.
- Do not operate the device if the covers or the housing are open. Before operation, check if the housing is firmly closed and all screws are tightly fastened.
- Disconnect the device from electrical power supply before service and maintenance, and when the device is not in use.



#### DANGER

**Electric shock caused by short-circuit**

This device falls under IEC protection class I.

- Make sure that the device is electrically connected to ground (earth). Connect the device only to a socket-outlet with ground (earth) connection.
- Do not cover the ground (earth) connection.
- Do not bypass the thermostatic switch or fuses.
- For replacement use fuses of the same type and rating only.
- Do not let the power cable come into contact with other cables. Handle the power cable and all connections with the mains with caution.
- Do not modify, bend, mechanically strain, put pressure on, pull or heat up the power cable.
- Make sure that the power cable is not crimped or damaged. Examine the power cable periodically for any defects.
- Do not immerse the device in water or other liquids. Do not install the device in a location where flooding may occur.
- Do not use the device during thunderstorms. Disconnect the device from the electrical power supply immediately.



**WARNING**  
**Risk of burns due to hot surface**

The surface and the inner parts of the device can become very hot during operation.

- Do not touch the device during operation.
- Allow the device to cool down for at least 15 minutes before handling.



**WARNING**  
**Risk of epileptic shock**

Strobe lighting can trigger seizures in photosensitive epilepsy. Sensitive persons should avoid looking at strobe lights.



**WARNING**  
**Possible eye damage caused by high light intensity**

Possibly hazardous optical radiation emitted from this device.

- Do not look at the operating light source. May be harmful to the eye.
- Do not look at the light source with optical instruments that may concentrate the light output.
- Make sure that persons are not looking directly into the light source when the device lights up suddenly. This can happen when the device is powered or when it receives DMX signal, or when certain menu items are selected.
- Disconnect power supply before servicing.
- Wear protective goggles if looking into light source during service or maintenance.



**Attention**  
**Power supply**

- Before connecting the device to the power supply, make sure that the current, voltage and frequency match the input voltage, current and frequency specified on the information label on the device.
- Make sure that the cross-sectional area of the extension cords and power cables is sufficient for the required power consumption of the device.



**Attention**  
**General safety**

- Do not insert objects into the air vents.
- Do not connect the device to a dimmer pack.
- Do not switch the device on and off in short intervals. This decreases the device's life.
- Do not shake the device. Avoid brute force when installing or operating the device.
- Change the lens or the LEDs if they are visibly damaged to such an extent that their effectiveness is impaired, for example by cracks or deep scratches. Contact your Highlite International dealer for more information, as servicing can be performed only by instructed or skilled persons.
- If the device is dropped or struck, disconnect the device from the electrical power supply immediately.



- If the device is exposed to extreme temperature variations (e.g. after transportation), do not switch it on immediately. Let the device reach room temperature before switching it on, otherwise it may be damaged by the formed condensation.
- If the device fails to work properly, discontinue the use immediately.



**Attention**  
**For professional use only**  
**This device shall be used only for the purposes it is designed for.**

This device is designed to be used as a professional stage light effect. Any incorrect use may lead to hazardous situations and result in injuries and material damage.

- This device is not suitable for households and for general lighting.
- This device is not designed for permanent operation.
- This device does not contain user-serviceable parts. Unauthorized modifications to the device will render the warranty void. Such modifications may result in injuries and material damage.



**Attention**  
**Before each use, examine the device visually for any defects.**

Make sure that:

- All screws used for installing the device or parts of the device are tightly fastened and are not corroded.
- The safety devices are not damaged.
- There are no deformations on housings, fixations and installation points.
- The lens is not cracked or damaged.
- The power cables are not damaged and do not show any material fatigue.



**Attention**  
**Do not expose the device to conditions that exceed the rated IP class conditions.**

This device is IP20 rated. IP (Ingress Protection) 20 class provides protection against solid objects greater than 12 mm, such as fingers, and no protection against harmful ingress of water.

## 2.2. Requirements for the User

This product may be used by ordinary persons. Maintenance may be carried by ordinary persons. Installation and service shall be carried out only by instructed or skilled persons. Contact your Highlite International dealer for more information.

Instructed persons have been instructed and trained by a skilled person, or are supervised by a skilled person, for specific tasks and work activities associated with the installation, service and maintenance of this product, so that they can identify risks and take precautions to avoid them.

Skilled persons have training or experience, which enables them to recognize risks and to avoid hazards associated with the installation, service and maintenance of this product.

Ordinary persons are all persons other than instructed persons and skilled persons. Ordinary persons include not only users of the product but also any other persons that may have access to the device or who may be in the vicinity of the device.

### 3. Description of the Device

The Performer 1500 Fresnel Q6 is equipped with a 6-color LED engine. This engine is customized with specially selected colors with specified wavelengths, ensuring a high CRI and even beam. It contains 48 color presets which are frequently used in theaters. The Performer has a CCT channel enabling you to set the color temperature between 1800–10000 K.

#### 3.1. Front View

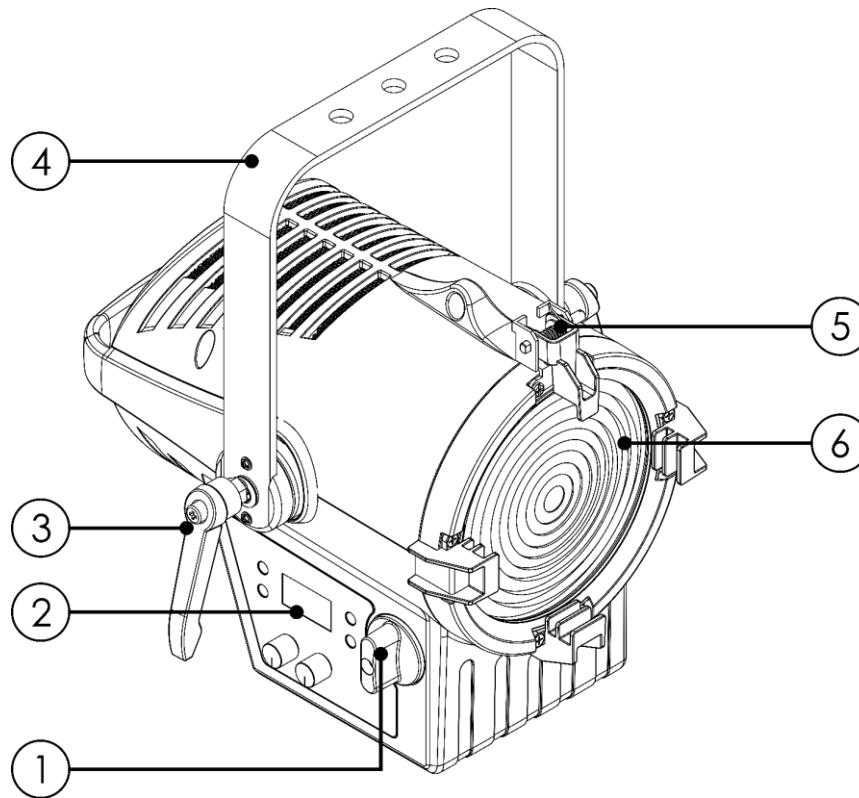

Fig. 02

- 01) Zoom control
- 02) Control panel: OLED display, control buttons and 2 rotatable controls
- 03) Adjustment screw
- 04) Mounting bracket
- 05) Barndoor retaining clip
- 06) 100 W RGBALC LED Module

3.2. Back View

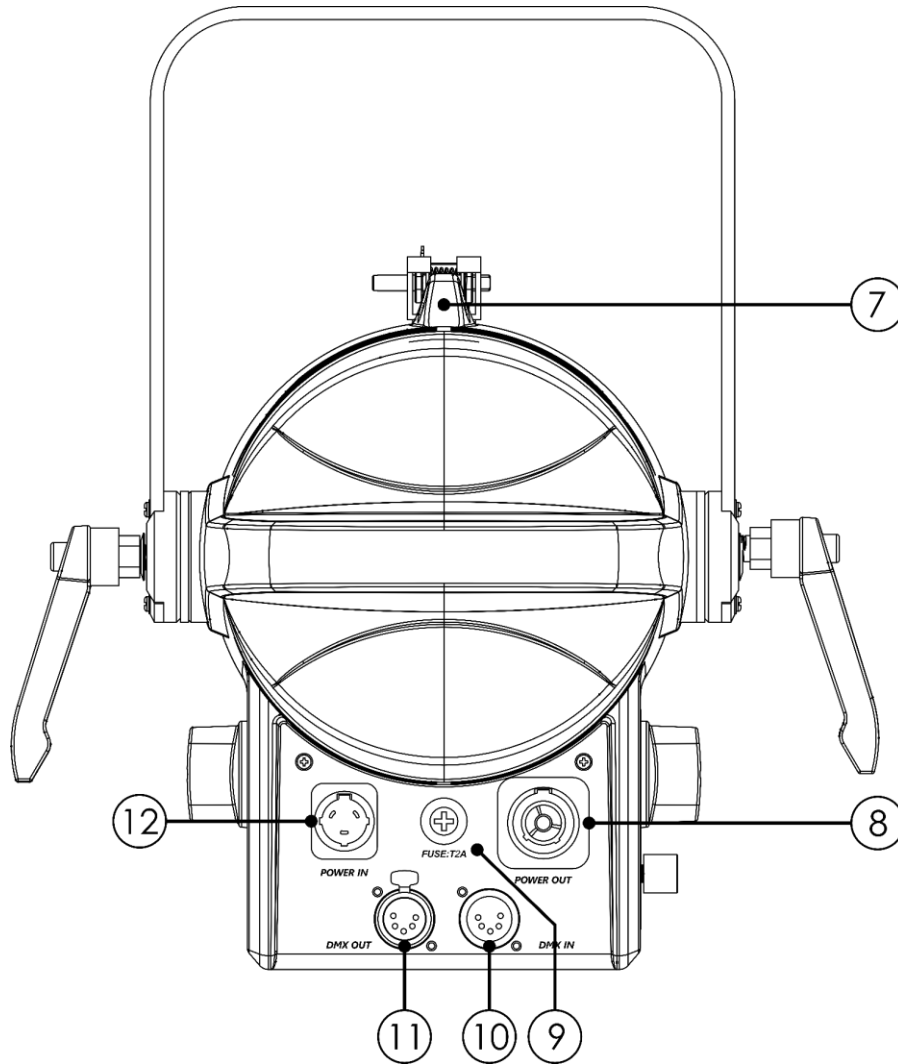

Fig. 03

- 07) Safety eye
- 08) Pro True1 power connector OUT
- 09) Fuse F2AL/250 V
- 10) 5-pin DMX connector IN
- 11) 5-pin DMX connector OUT
- 12) Pro True1 power connector IN

### 3.3. Product Specifications

Model:	Performer 1500 Fresnel Q6
<b>Electrical:</b>	
Input voltage:	100–240 V AC, 50/60 Hz
Power consumption:	120 W
Max. power:	100 W
Power factor:	0,9
Fuse:	F2AL/250 V
<b>Physical:</b>	
Dimensions:	450 x 322 x 370 mm (LxWxH)
Weight:	5,5 kg
<b>Optics:</b>	
Light source:	100 W RGBALC LED Module
Dimmer:	0–100 %
Strobe:	0–25 Hz
Beam angle:	10–50°
Field angle:	18–75°
Lumen:	3111 lm
Lux @ 2 m:	12195 lx
Color temperature:	1800–8000 K
Zoom:	Manual
CRI:	90
Refresh rate:	>1000 Hz
<b>Operation and control:</b>	
Control:	Stand-alone (Knob mode, Static, Color presets, Auto) Master/Slave (Knob mode, Static, Color presets, Auto) DMX-512/RDM
DMX channels:	BASIC (3 channels), HSIC (7 channels), SSP (8 channels), CMY (10 channels), TOUR (13 channels), TR16 (20 channels)
Control panel:	OLED display and buttons
<b>Connections:</b>	
Power connections:	Pro True1 power connectors IN/OUT
Data connections:	5-pin DMX connectors IN/OUT
Signal pinouts:	5-pin: pin 1 (ground), pin 2 (-), pin 3 (+), pin 4 (N/C), pin 5 (N/C)
<b>Construction:</b>	
Housing:	Die-cast aluminum
Color:	Black
IP rating:	IP20
Cooling:	Forced convection
<b>Thermal:</b>	
Maximum ambient temperature $t_a$ :	40 °C
Maximum housing temperature $t_c$ :	70 °C
<b>Minimum distance:</b>	
Minimum distance from flammable surfaces:	0,5 m
Minimum distance to lighted object:	2 m

### 3.4. Optional Accessories

The Performer 1500 Fresnel Q6 is delivered without accessories. You can additionally purchase the following accessories:

Product code: [33160](#) (Barndoor for Performer 1500 Fresnel)

### 3.5. Dimensions

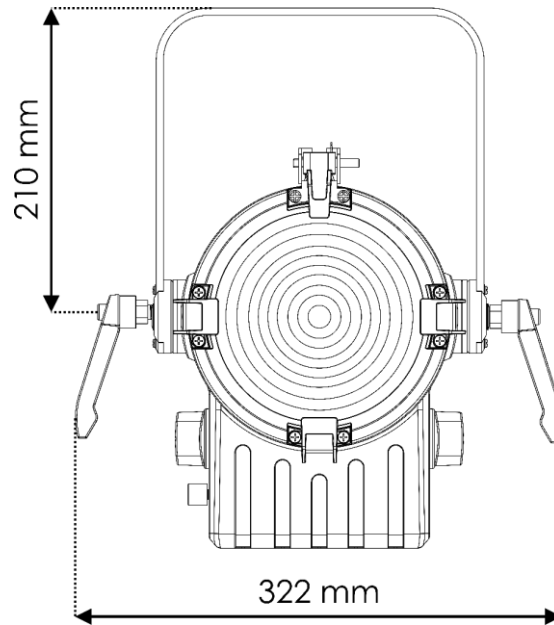

Fig. 04

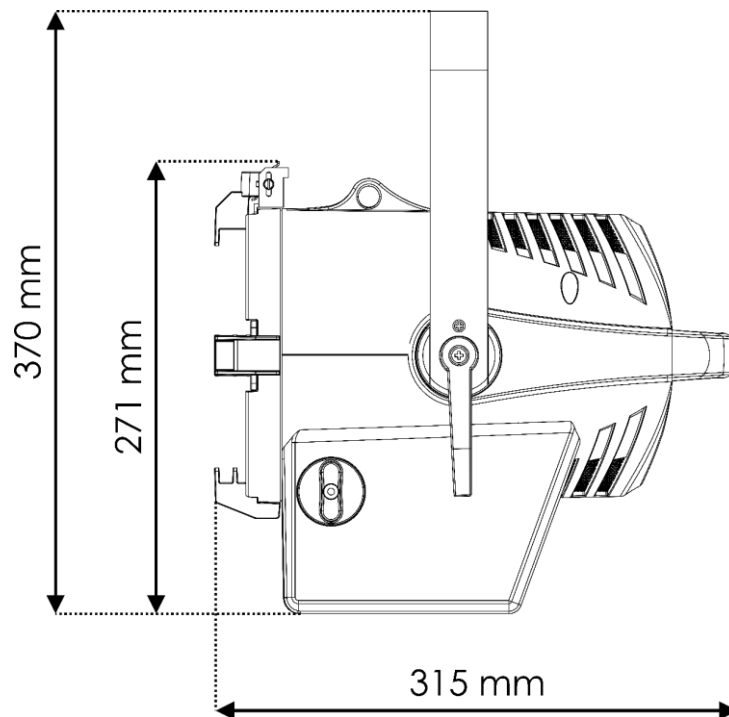

Fig. 05

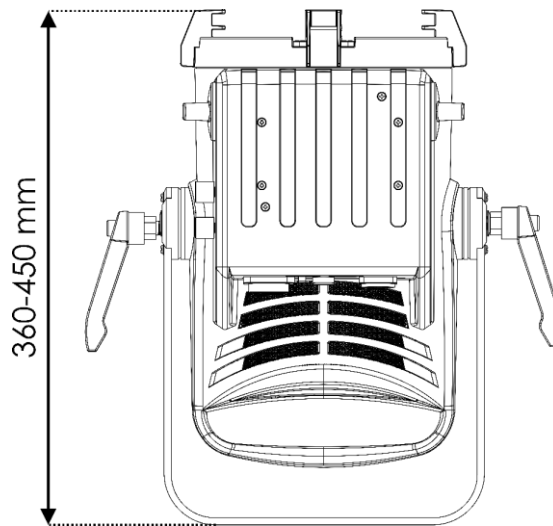

Fig. 06

## 4. Installation

### 4.1. Safety Instructions for Installation



**WARNING**  
Incorrect installation can cause serious injuries and damage of property.

If trussing systems are used, installation must be carried out only by instructed or skilled persons.

Follow all applicable European, national and local safety regulations concerning rigging and trussing.

### 4.2. Personal Protective Equipment

During installation and rigging wear personal protective equipment in compliance with the national and site-specific regulations.

### 4.3. Installation Site Requirements

- The device can be used only indoors.
- The device can be mounted to a truss or other rigging structure in any orientation.
- The minimum distance to other objects must be bigger than 0,5 m.
- The minimum distance between the light output and the illuminated surface must be bigger than 2 m.
- The maximum ambient temperature  $t_a = 40\text{ °C}$  must never be exceeded.
- The relative humidity must not exceed 50 % with an ambient temperature of 40 °C.

### 4.4. Rigging

The device can be positioned on a flat surface or mounted to a truss or other rigging structure in any orientation. Make sure that all loads are within the pre-determined limits of the supporting structure.



**CAUTION**  
Restrict the access under the work area during rigging and/or derigging.

To mount the device, follow the steps below:

- 01) Use a clamp to attach the device to the supporting structure, as shown in Fig. 07. Make sure that the device cannot move freely. Optionally, you can use the Slide Complete to attach the device.
- 02) Secure the device with a secondary suspension, for example a safety cable. Make sure that the secondary suspension can hold 10 times the weight of the device. If possible, the secondary suspension should be attached to a supporting structure independent of the primary suspension. Put the safety cable through the **safety eye (07)**, as shown in Fig. 07.

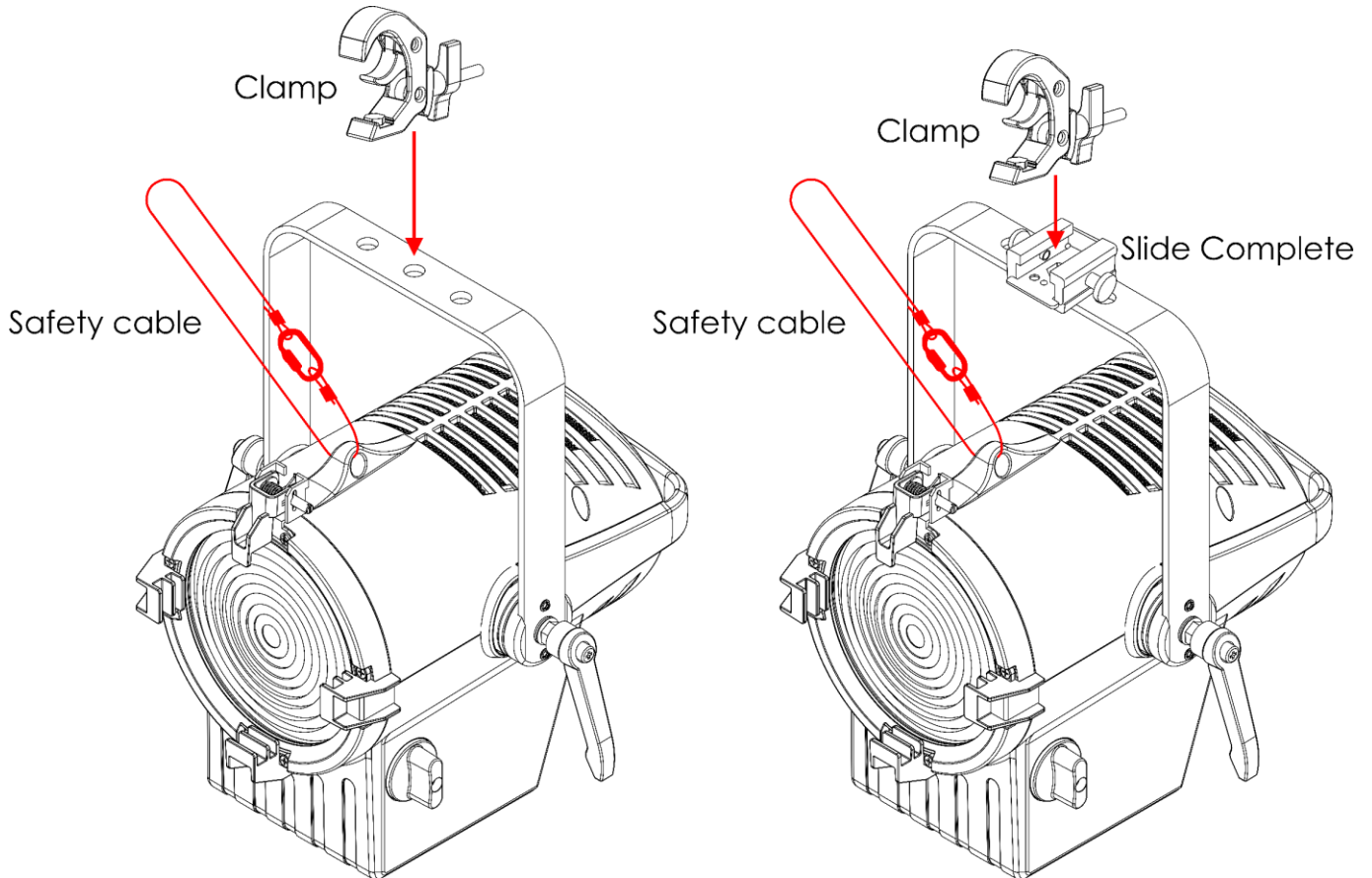

Fig. 07

#### 4.4.1. Angle Adjustment

You can adjust the angle of the device with the 2 **adjustment screws (03)**.

- 01) Turn the **adjustment screws (03)** counterclockwise to release them.
- 02) Tilt the device to the desired angle (see Fig. 08).
- 03) Turn the **adjustment screws (03)** clockwise to tighten them. Make sure that the device cannot move freely after the **adjustment screws (03)** are tightened.

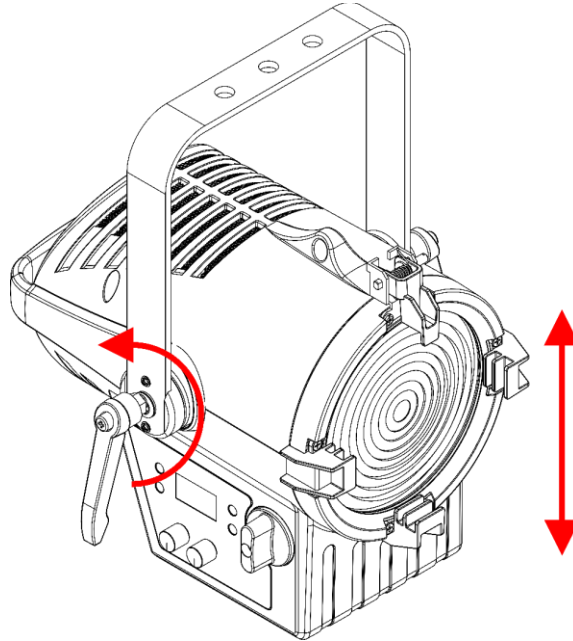

Fig. 08

#### 4.4.2. Zoom Adjustment

You can adjust the zoom of the device with the **zoom control (01)**.

- 01) Turn the **zoom control (01)** to set the desired zoom (see Fig. 09).

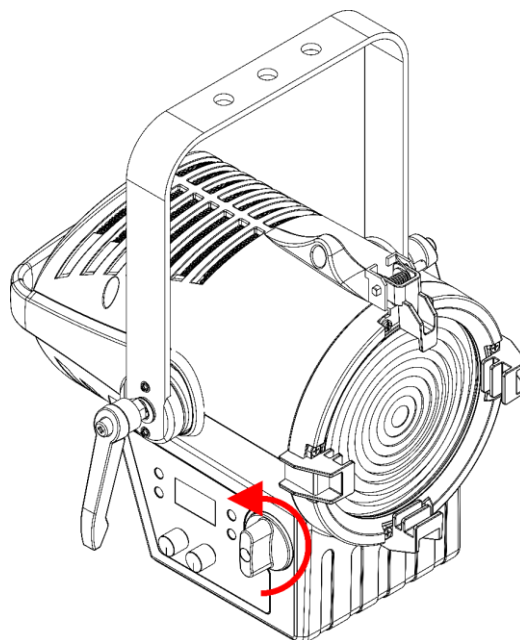

Fig. 09



#### 4.5. Barndoor Installation

The barndoor holder is equipped with a spring-loaded retaining clip. This prevents the barndoor from falling out.

- 01) Release the retaining clip by pressing the lock towards the lens and pressing on the longer side of the screw. The retaining clip will open (see Fig. 10).
- 02) Insert the barndoor as shown in Fig. 11.
- 03) Press the retaining clip towards the lens to lock the barndoor in position.

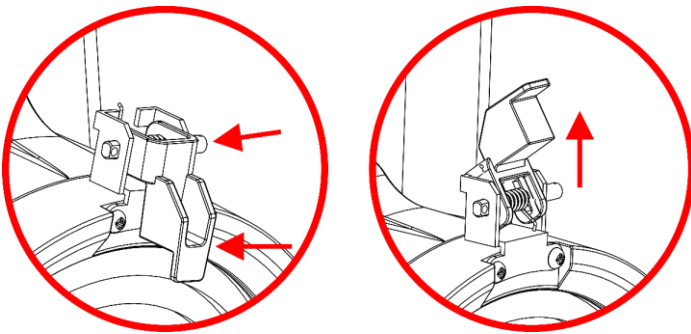

Fig. 10

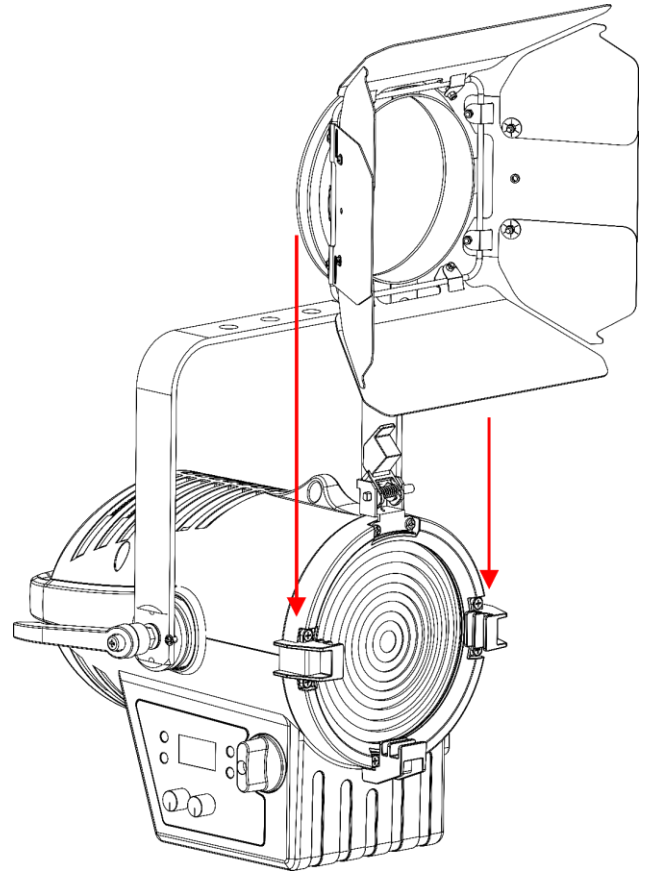

Fig. 11

## 4.6. Connecting to Power Supply



**DANGER**  
Electric shock caused by short-circuit

The device accepts AC mains power at 100–240 V and 50/60 Hz. Do not supply power at any other voltage or frequency to the device.

This device falls under IEC protection class I. Make sure that the device is always electrically connected to the ground (earth).

Before connecting the device to the socket-outlet:

- Make sure that the power supply matches the input voltage specified on the information label on the device.
- Make sure that the socket-outlet has ground (earth) connection.

Connect the device to the socket-outlet with a power plug. Do not connect the device to a dimmer pack, as this may damage the device.

## 4.7. Power Linking of Multiple Devices

This device supports power linking. Power can be relayed to another device via the power OUT connector. Note that the input and the output connectors have different designs: one type cannot be connected to the other.

Power linking of multiple devices must be carried out only by instructed or skilled persons.



**WARNING**  
Incorrect power linking may lead to overload of the electrical circuit and result in serious injuries and damage of property.

To prevent overload of the electrical circuit, when power linking multiple devices:

- Use cables with sufficient current-carrying capacity. The power cable supplied with the device is not suitable for power linking of multiple devices.
- Make sure that the total current draw of the device and all connected devices does not exceed the rated capacity of the power cables and the circuit breaker.
- Do not link more devices on one power link than the maximum recommended number.

Maximum recommended number of devices:

- at 100–120 V: 14 devices Performer 1500 Fresnel Q6
- at 200–240 V: 28 devices Performer 1500 Fresnel Q6

## 5. Setup

---

### 5.1. Warnings and Precautions



**Attention**

**Connect all data cables before supplying power.**

**Disconnect power supply before connecting or disconnecting data cables.**

### 5.2. Stand-alone Setup

When the Performer 1500 Fresnel Tungsten is not connected to a controller or to other devices, it functions as a stand-alone device. It can be operated manually or in auto mode.

For more information about the control modes, refer to **6.2. Control Modes** on page 21.

### 5.3. DMX Connection

#### 5.3.1. DMX-512 Protocol

You need a DMX serial data link to run light shows of one or more devices using a DMX-512 controller or to run synchronized shows of two or more devices set in a master/slave operating mode.

The Performer 1500 Fresnel Tungsten has 5-pin DMX signal IN and OUT connectors.

The pin assignment is as follows:

- 5-pin: pin 1 (ground), pin 2 (-), pin 3 (+), pin 4 (N/C), pin 5 (N/C)

Devices on a serial data link must be daisy-chained in a single line. The number of devices that you can control on one data link is limited by the combined number of the DMX channels of the connected devices and the 512 channels available in one DMX universe.

To comply with the TIA-485 standard, no more than 32 devices should be connected on one data link. In order to connect more than 32 devices on one data link, you must use a DMX optically isolated splitter/booster, otherwise this may result in deterioration of the DMX signal.

**Note:**

- Maximum recommended DMX data link distance: 300 m
- Maximum recommended number of devices on a DMX data link: 32 devices

## 5.3.2. DMX Cables

Shielded twisted-pair cables with 5-pin XLR connectors must be used for reliable DMX connection. You can purchase DMX cables directly from your Highlite International dealer or make your own cables.

If you use 3-pin XLR audio cables for DMX data transmission, this may lead to signal degradation and unreliable operation of the DMX network.

When you make your own DMX cables, make sure that you connect the pins and wires correctly as shown in Fig. 12.

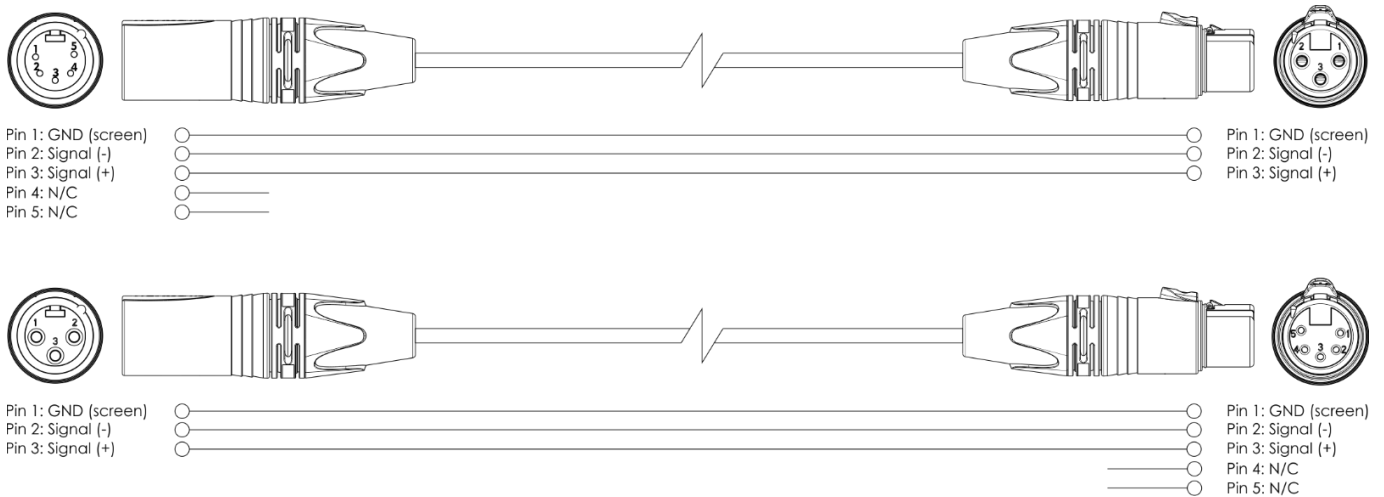

Fig. 12

## 5.3.3. Master/Slave Setup

The Performer 1500 Fresnel Q6 supports master/slave control mode. To connect multiple devices in master/slave setup, follow the steps below:

- 01) Connect the first device's DMX OUT connector to the second device's DMX IN connector.
- 02) Repeat step 1 to connect all devices as shown in Fig. 13.
- 03) Connect a DMX terminator (120 Ω resistor) to the DMX OUT connector of the last device in the setup.
- 04) Set the first device on the data link as a master device. See **6.6.4. Run Mode** on page 27 for more information.
- 05) Set the remaining devices to slave mode. See **6.6.4. Run Mode** on page 27 for more information.

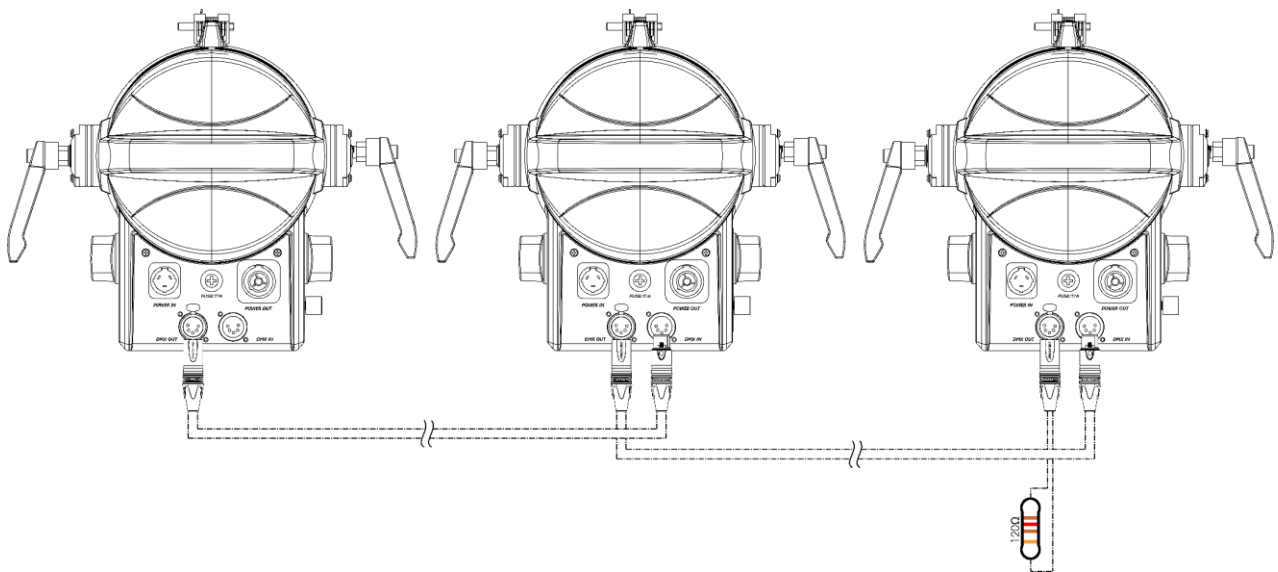

Fig. 13

## 5.3.4. DMX Linking

To connect multiple devices on one DMX data link, follow the steps below:

- 01) Use a 5-pin DMX cable to connect the DMX OUT connector of the lighting controller to the DMX IN connector of the first device.
- 02) Connect the first device's DMX OUT connector to the second device's DMX IN connector with a 5-pin DMX cable.
- 03) Repeat step 2 to connect all devices in a daisy-chain as shown in Fig. 14.
- 04) Connect a DMX terminator (120 Ω resistor) to the DMX OUT connector of the last device on the data link.

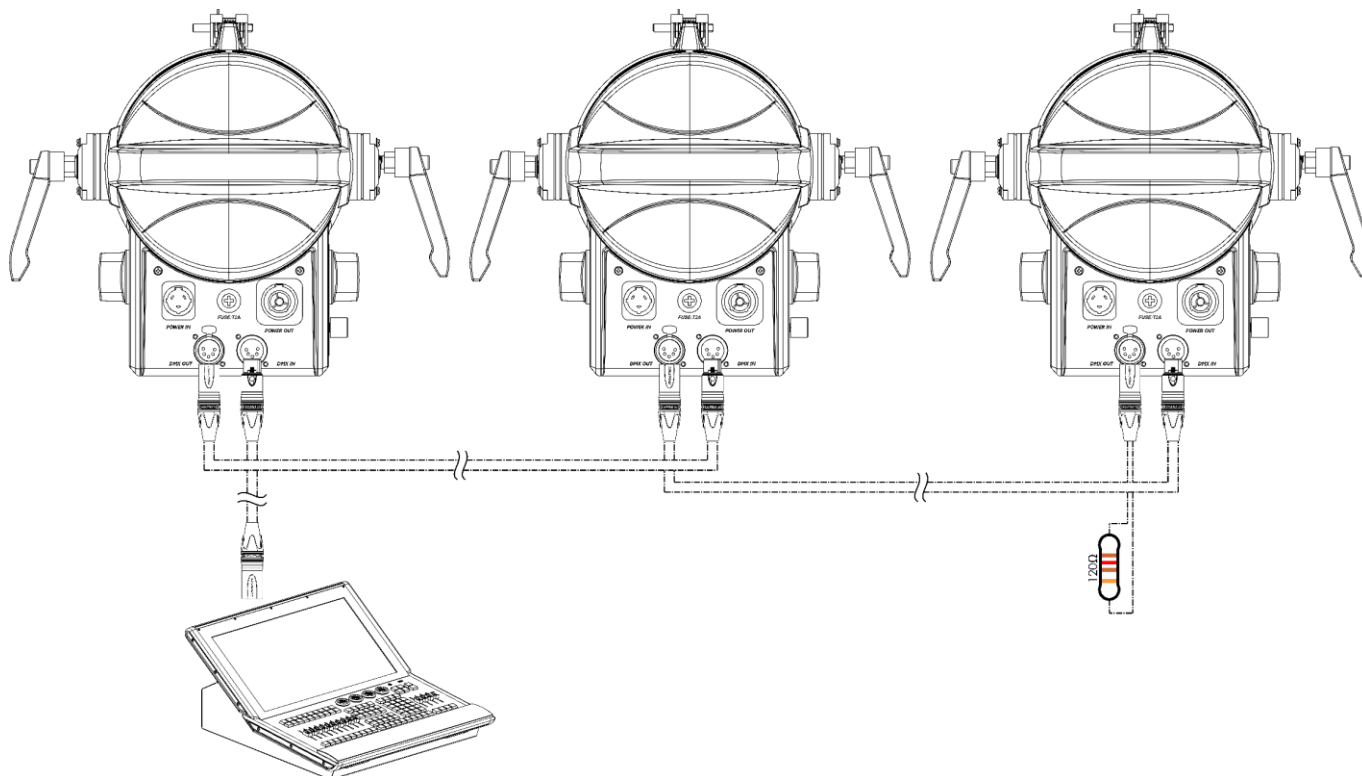

Fig. 14

## 5.3.5. DMX Addressing

In a setup with multiple devices, make sure that you set the DMX starting address of each device correctly. The Performer 1500 Fresnel Q6 has 6 personalities: 3 channels, 7 channels, 8 channels, 10 channels, 13 channels and 20 channels.

If you want to connect multiple devices on one data link and use them in 20-channel mode, for example, follow the steps below:

- 01) Set the starting address of the 1<sup>st</sup> device on the data link to 1 (001).
- 02) Set the starting address of the 2<sup>nd</sup> device on the data link to 21 (021), as  $1 + 20 = 21$ .
- 03) Set the starting address of the 3<sup>rd</sup> device on the data link to 41 (041) as  $21 + 20 = 41$ .
- 04) Continue assigning the starting addresses of the remaining devices by adding each time 20 to the previous number.

Make sure that you do not have any overlapping channels in order to control each Performer 1500 Fresnel Q6 correctly. If two or more devices are addressed similarly, they will work similarly.

## 6. Operation

### 6.1. Safety Instructions for Operation



**Attention**

**This device must be used only for the purposes it is designed for.**

This device is intended for professional use as a theater spot. It is suitable only for indoor installation. This device is not suitable for households and for general lighting.

Any other use, not mentioned under intended use, is regarded as non-intended and incorrect use.



**Attention**

**Power supply**

Before connecting the device to the power supply, make sure that the current, voltage and frequency match the input voltage, current and frequency specified on the information label on the device.

### 6.2. Control Modes

The Performer 1500 Fresnel Q6 supports the following control modes:

- Stand-alone: Knob mode, Static, Color presets, Auto
- Master/Slave: Knob mode, Static, Color presets, Auto
- DMX-512, RDM 3, 7, 8, 10, 13, 20 channels

For more information about how to connect the devices, refer to **5. Setup** on pages 18–20.

To operate the device manually as a stand-alone device or in a master/slave setup:

- Adjust the functions by turning the **rotatable controls (02)** in Knob Mode menu. See **6.6.1. Knob Mode** on page 26 for more information.
- Adjust the levels for red, green, blue, amber, lime and cyan in Static menu. See **6.6.2. Static** on page 26 for more information.

To run one of the built-in programs in auto operation mode without a DMX controller:

- 01) Select one of the 10 built-in programs in Auto Program menu. See **6.6.7. Auto Programs** on page 28 for more information.
- 02) Set the speed of the built-in programs in Auto Program menu. See **6.6.7. Auto Programs** on page 28 for more information.

To run the preset colors without a DMX controller:

- 01) Select one of the 48 preset colors in Preset Color menu. See **6.6.12. Preset Color** on page 33 for more information.

To operate the device with a DMX controller:

- 01) Set the DMX starting address of the device in the DMX Address menu. See **5.3.5. DMX Addressing** on page 20 and **6.6.3. DMX Address** on page 27.
- 02) Select the DMX channel mode. See **6.6.5. Personality (DMX Channel Modes)** on page 27 for more information. See **6.7. DMX Channels** on pages 34–38 for complete overview of all DMX channels.

### 6.3. Control Panel

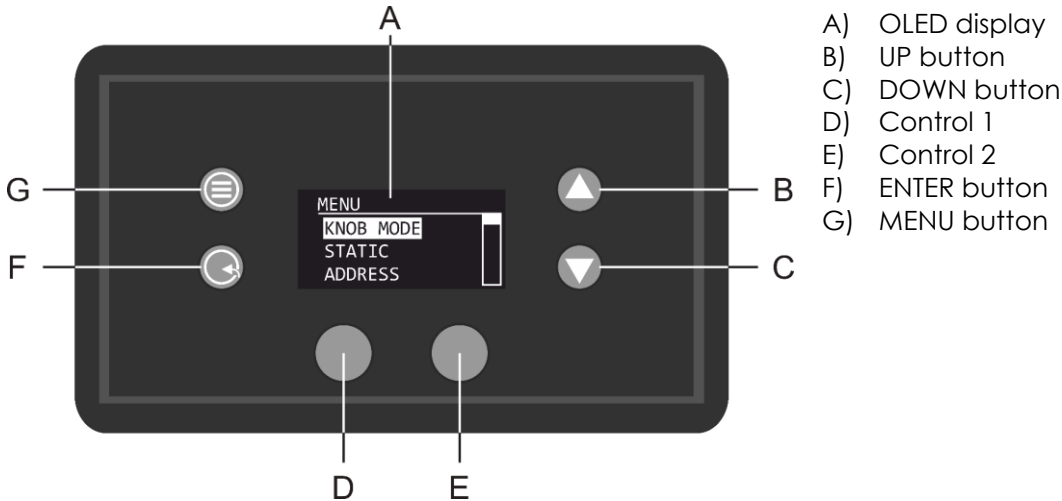

Fig. 15

- Use the **MENU** button to exit the current submenu, to return to the Main Menu and to return to the start screen.
- Use the **UP/DOWN** buttons to navigate through the menus or to increase/decrease numeric values.
- Use the **ENTER** button to open the desired menu, to confirm your choice or to set the currently selected value.
- Use the rotatable controls to adjust settings in Knob mode. See **6.6.1. Knob Mode** on page 26 for more information.

### 6.4. Start-up

Upon start-up the display will show a splash screen with the logo of Showtec. Press any button to enter the password and/or enter the Main Menu.

**Note:**

- If no button is pressed, after the preset number of seconds of inactivity, the display will turn off. Press any button to turn the display on. See **6.6.9.7. Disp Time (Display Time)** on page 31 for more information
- By default the display is locked. To access the main menu, you need to enter the **password**. The default password is pressing the **UP/DOWN** buttons in the following order: **UP, DOWN, UP, DOWN, ENTER**. Deactivating the display lock does not affect the submenu items which by default require a password. See **6.6.9.6. Disp Key (Display Lock)** on page 31 for more information.

### 6.5. Menu Overview

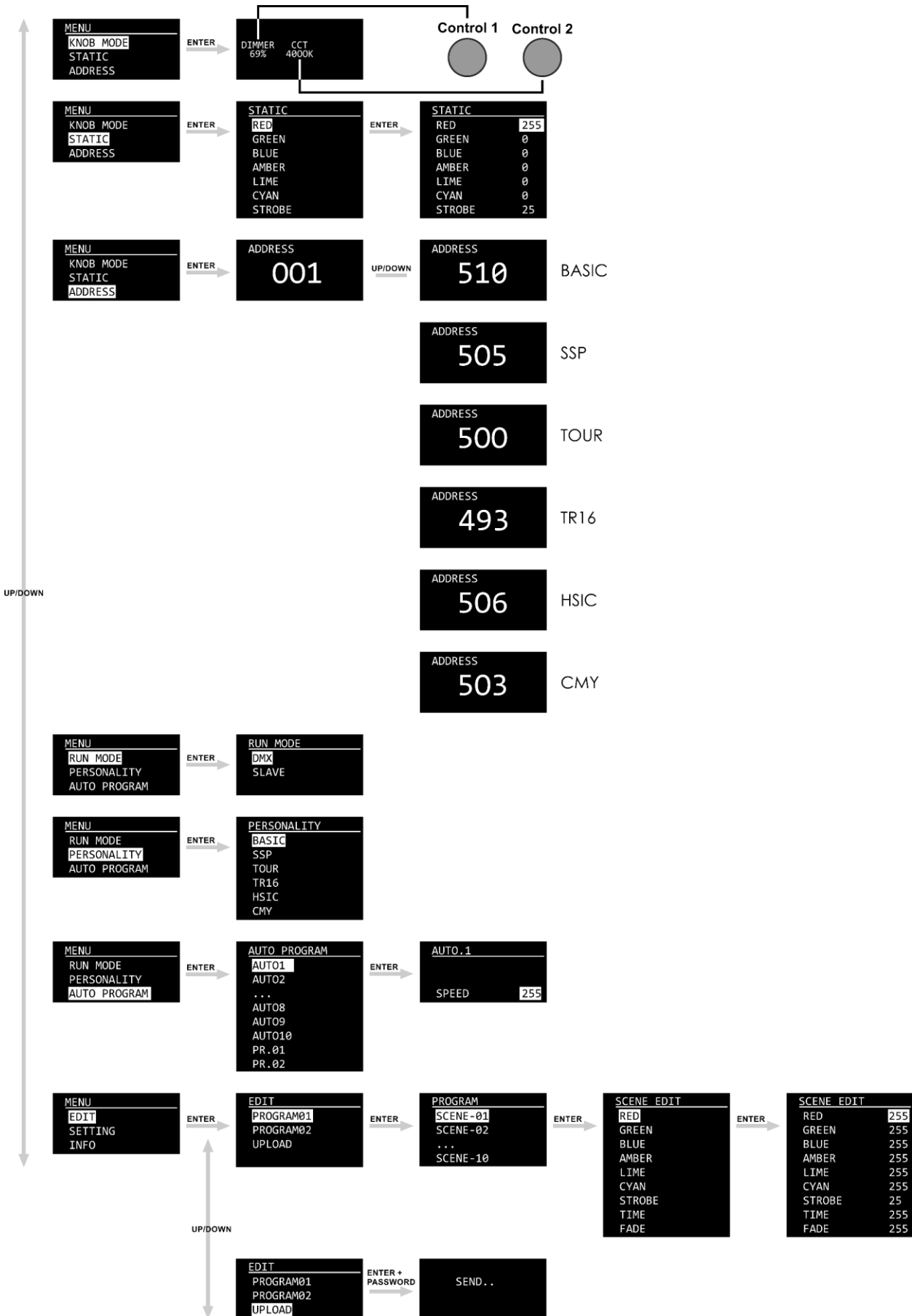



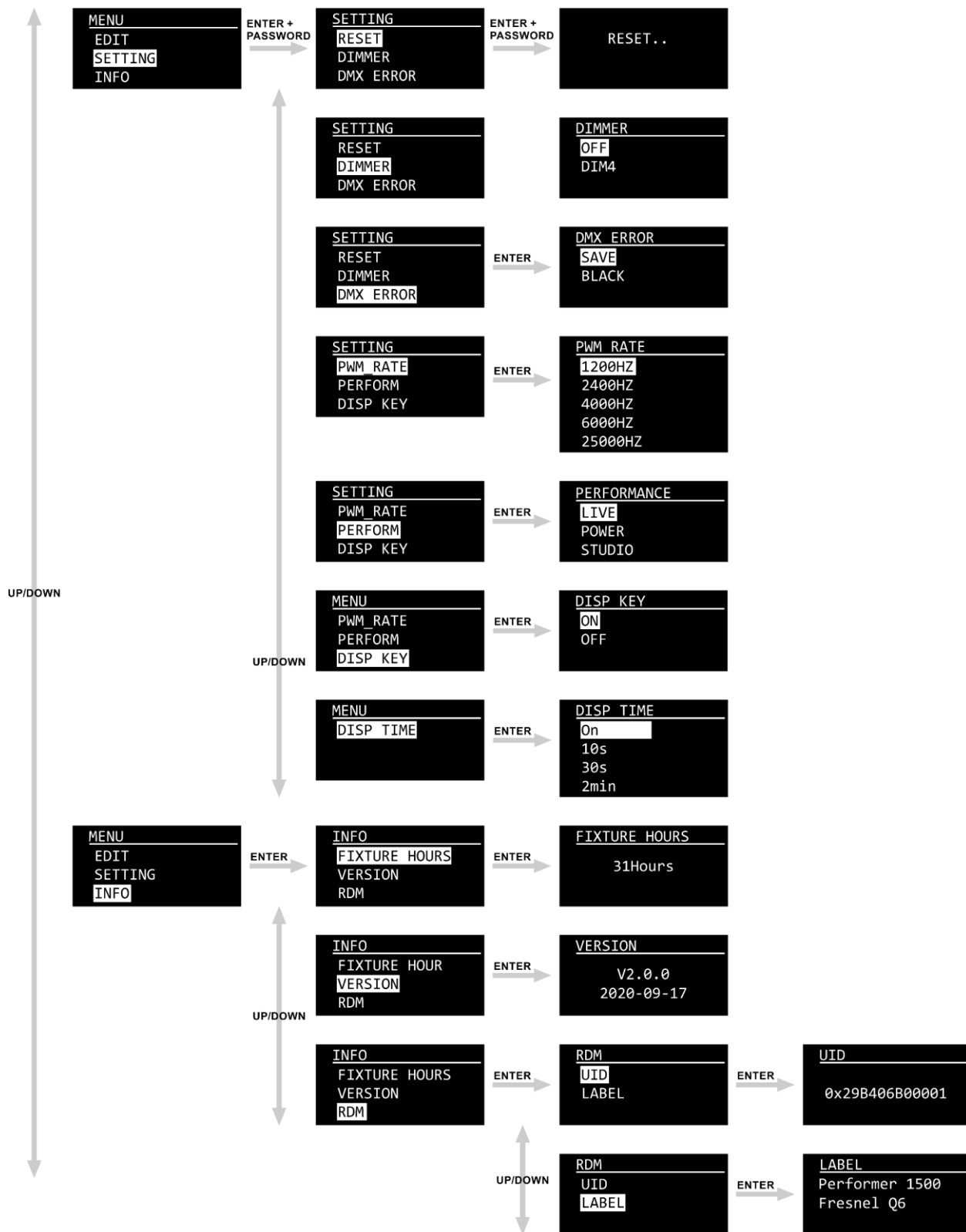

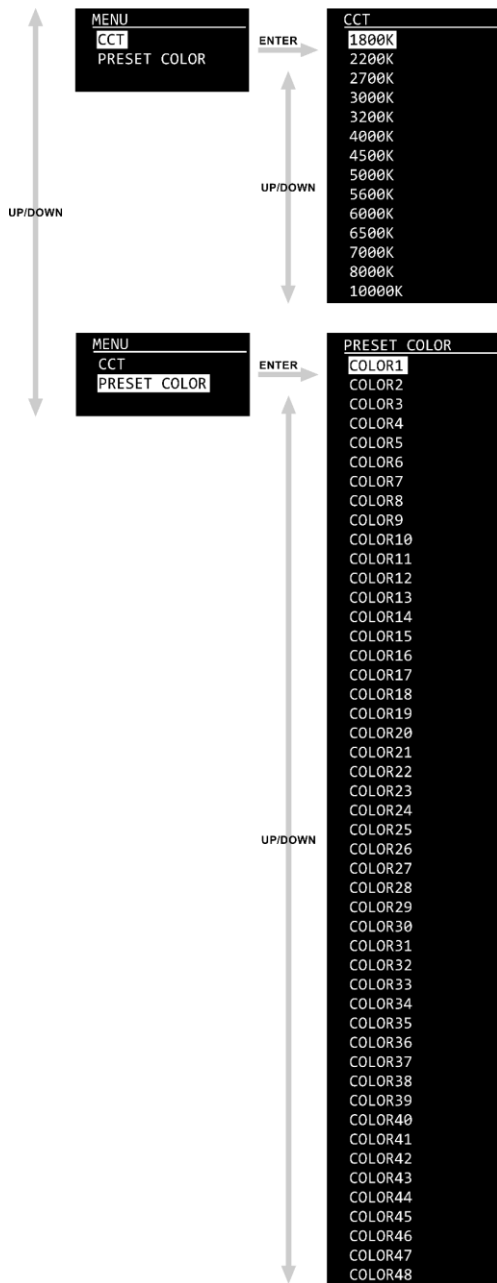

## 6.6. Main Menu Options

The main menu has the following options:

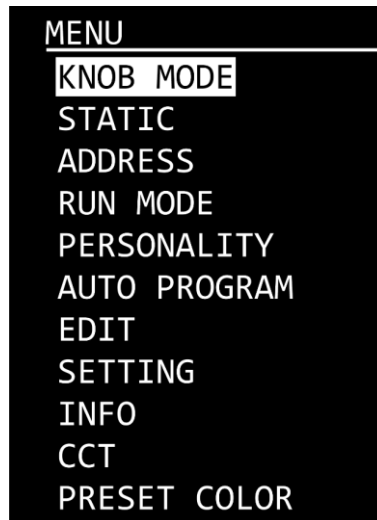

- 01) Press the **UP/DOWN** buttons to navigate through the main menu.
- 02) Press the **ENTER** button to open the submenus.

**Note:** Some of the submenus require a password. The default password is pressing the **UP/DOWN** buttons in the following order: **UP, DOWN, UP, DOWN, ENTER**. Deactivating the display lock does not affect the submenu items which by default require a password.

### 6.6.1. Knob Mode

In this menu you can set the dimmer and CCT.

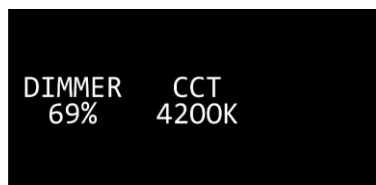

- 01) Turn the controls (**D/E**) to adjust settings.
- 02) The adjustment ranges are:
  - **D:** Dimmer, from dark to brightest (0–100 %)
  - **E:** CCT (1800 K, 2200 K, 2700 K, 3000 K, 3200 K, 4000 K, 4500 K, 5000 K, 5600 K, 6000 K, 6500 K, 7000 K, 8000 K, 10000K)
- 03) Once you have set your settings, press each of the controls (**D/E**) to save your settings. Otherwise, your settings will be lost upon returning to the previous menu.

### 6.6.2. Static

In this menu, you can set the static colors to create an infinite range of colors.

- 01) Press the **UP/DOWN** buttons to scroll through the static colors (RED, GREEN, BLUE, AMBER, LIME, CYAN) and STROBE.
- 02) Press the **ENTER** button to open the settings submenu.
- 03) Press the **UP/DOWN** buttons to increase/decrease the values.
  - Color intensity (RED, GREEN, BLUE, AMBER, LIME, CYAN): the adjustment range is between 0–255, from low to high intensity
  - STROBE frequency: the adjustment range is between 0–25, from OFF to high frequency
- 04) Press the **ENTER** button to set the value and to move to the next setting.

### 6.6.3. DMX Address

In this menu you can set the device's DMX starting address.

- 01) Press the **UP/DOWN** buttons to set the desired DMX address. The adjustment range is between 001 and 493/500/503/505/506/510, depending on the currently selected DMX channel mode.
- 02) Press the **ENTER** button to save the changes.

### 6.6.4. Run Mode

In this menu you can set the control mode of the device.

- 01) Press the **UP/DOWN** buttons to toggle between the following 2 options:
  - **DMX**: the device will operate in DMX Mode.
  - **SLAVE**: the device will operate as a slave in Master/Slave Mode. It means that it will react the same as the master device.
- 02) Press the **ENTER** button to confirm your choice.

### 6.6.5. Personality (DMX Channel Modes)

In this menu you can set the DMX channel mode (personality).

- 01) Press the **UP/DOWN** buttons to select the desired DMX channel mode. There are 6 options available:

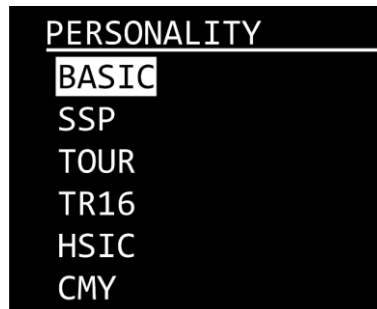

<b>BASIC:</b>	3 channels	<b>TR16:</b>	20 channels
<b>SSP:</b>	8 channels	<b>HSIC:</b>	7 channels
<b>TOUR:</b>	13 channels	<b>CMY:</b>	10 channels

- 02) Press the **ENTER** button to confirm your choice. See pages 34–38 for the DMX channel modes.

### 6.6.6. Preset Color

In this menu you can choose a preset color mix.

- 01) Press the **UP/DOWN** buttons to select one of the 48 presets.
- 02) Press the **ENTER** button to confirm your choice.

## 6.6.7. Auto Programs

In this menu you can select a built-in auto program or a custom program. There are 10 uneditable auto programs and 2 custom programs, which can be edited in Edit menu. See **6.6.8. Edit** on page 28.

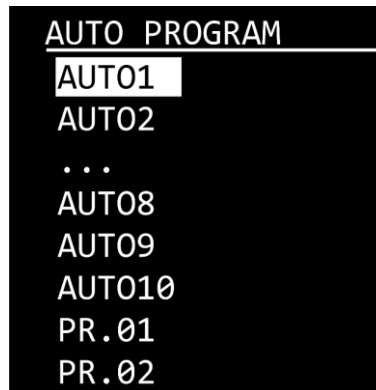

- 01) Press the **UP/DOWN** buttons to choose an auto or a custom program.
- 02) Press the **ENTER** button to confirm your choice.
- 03) If you have chosen one of the auto programs, after pressing the **ENTER** button you can additionally adjust the speed.
- 04) Press the **UP/DOWN** buttons to set the program speed. The adjustment range is between 0–255, from slow to fast.
- 05) Press the **ENTER** button to set the speed.

## 6.6.8. Edit

In this menu you can edit the custom programs thus creating your own custom show.

- 01) Press the **UP/DOWN** buttons to choose the custom program you want to edit (PROGRAM01–02).
- 02) Press the **ENTER** button to confirm the selection. Each custom program has 10 scenes, which can be edited:

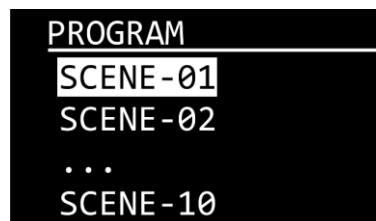

- 03) Press the **UP/DOWN** buttons to select the desired scene.
- 04) Press the **ENTER** button to enter the scene settings.
- 05) Press the **UP/DOWN** buttons to scroll through the 6 colors (RED, GREEN, BLUE, AMBER, LIME, CYAN), and the STROBE, TIME and FADE options.
- 06) Press the **ENTER** button to open the settings submenu.

SCENE EDIT	
RED	255
GREEN	0
BLUE	0
AMBER	0
LIME	0
CYAN	0
STROBE	25
TIME	255
FADE	0

- 07) Press the **UP/DOWN** buttons to increase/decrease the values.
- Color intensity (RED, GREEN, BLUE, AMBER, LIME, CYAN): the adjustment range is between 0-255, from low to high intensity
  - STROBE frequency: the adjustment range is between 0–25, from OFF to high frequency
  - TIME (duration of the scene): the adjustment range is between 0–255, from 0 to 255 seconds
  - FADE (transition time between the scenes): the adjustment range is between 0–255, from 0 to 255 seconds.
- 08) Press the **ENTER** button to set the value and to move to the next setting.

**Note:** For each custom program you can create 30 scenes, which makes it possible to create 300 customized scenes in total.

#### 6.6.8.1. Upload

In this submenu you can export the custom programs from the master device to the connected slave devices.

- 01) Select UPLOAD and press the **ENTER** button to open the submenu.
- 02) Enter the password, pressing the buttons in the following order: **UP, DOWN, UP, DOWN.**
- 03) Press the **ENTER** button to confirm. During upload, the light output will turn yellow and the display will show:

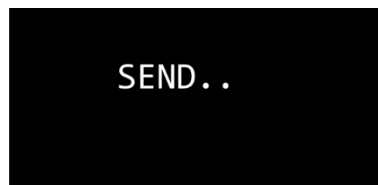

- 04) When the upload is finished, the display will show OK.
- 05) Press the **ENTER** button to confirm and exit the submenu.

## 6.6.9. Settings

In this menu you can adjust the device's settings. This menu requires the **password**. The default password is pressing the **UP/DOWN** buttons in the following order: **UP, DOWN, UP, DOWN**.

- 01) Enter the password to access the menu.
- 02) Press the **ENTER** button to confirm the password.
- 03) Press the **UP/DOWN** buttons to scroll through the following options:

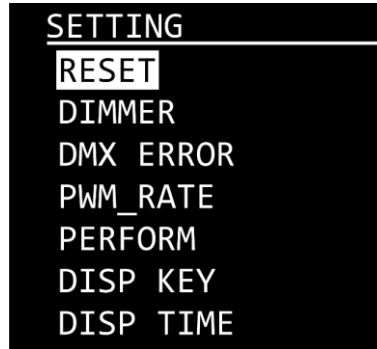

### 6.6.9.1. Reset

In this submenu you can restore the default factory settings and reset the custom programs.

- 01) Select **RESET** and press the **ENTER** button to open the submenu.
- 02) Enter the password, pressing the buttons in the following order: **UP, DOWN, UP, DOWN**.
- 03) Press the **ENTER** button to confirm. During reset the display will show:



- 04) When the resetting is finished, the display will show **OK**.
- 05) Press the **ENTER** button to confirm and exit the submenu.

### 6.6.9.2. Dimmer

In this submenu you can adjust the dimmer speed.

- 01) Select **DIMMER** and press the **ENTER** button to open the submenu.
- 02) Press the **UP/DOWN** buttons to choose one of the following options:
  - DIM 4: non-linear dimmer
  - OFF: linear dimmer
- 03) Press the **ENTER** button to confirm your choice.

### 6.6.9.3. DMX Error

In this submenu, you can determine the behavior of the device in case of a DMX failure.

- 01) Select **DMX ERROR** and press the **ENTER** button to open the submenu.
- 02) Press the **UP/DOWN** buttons to toggle between the following 2 options:
  - **SAVE**: in case of a DMX signal failure the device will use the last properly received DMX signal ensuring uninterrupted performance
  - **BLACK**: in case of a DMX signal failure the device will black out the light output
- 03) Press the **ENTER** button to confirm your choice.

### 6.6.9.4. PWM Rate

In this submenu you can set the PWM (Pulse Width Modulation) frequency.

- 01) Select PWM RATE and press the **ENTER** button to open the submenu.
- 02) Press the **UP/DOWN** buttons to choose the desired PWM frequency.  
The available options are: 1200 Hz, 2000 Hz, 4000 Hz, 6000 Hz and 25000 Hz.  
**Note:** The higher the PWM frequency, the lower the dimmer's grayscale.
- 03) Press the **ENTER** button to set the value.

### 6.6.9.5. Performance

In this menu you can set the performance of the Performer.

- 01) Select PERFORMANCE and press the **ENTER** button to open the submenu.
- 02) Press the **UP/DOWN** buttons to choose the desired performance mode. The available options are:
  - LIVE: Default mode. It provides a compromise between output quality and noise level
  - POWER: Output-oriented mode. The device does not offer any consideration for noise level and operates at full power
  - STUDIO: Noise level-oriented mode. It emits little noise and operates at moderate power level
- 03) Press the **ENTER** button to confirm your choice.

### 6.6.9.6. Disp Key (Display Lock)

In this menu you can activate the display lock.

- 01) Press the **UP/DOWN** buttons to toggle between ON and OFF.
  - ON: display lock is on. The display turns off if no button is pressed within the preset amount of time. To access the main menu, you will need to enter the password. The default password is pressing the **UP/DOWN** buttons in the following order: **UP, DOWN, UP, DOWN, ENTER**.
  - OFF: the main menu remains unlocked after the display turns off.

**Note:** Deactivating the display lock does not affect the submenu items which by default require a password.

### 6.6.9.7. Disp Time (Display Time)

In this menu you can set the amount of time that needs to pass before the display turns off, if no button is pressed.

- 01) Press the **UP/DOWN** buttons to select one of the following options: 10 s/30 s/2 min/ON.
- 02) Press the **ENTER** button to confirm your choice.

### 6.6.10. Information

In this menu you can view the total operation time, current software version and the RDM details of the device.

- 01) Press the **UP/DOWN** buttons to choose FIXTURE HOURS, VERSION or RDM.
- 02) Press the **ENTER** button to confirm the selection.

#### 6.6.10.1. Fixture Hours

In this submenu you can view the total operation time of the device.



## 6.6.10.2. Version

In this submenu you can view the current version of the installed firmware.

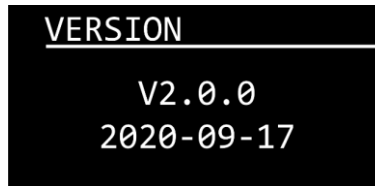

## 6.6.10.3. RDM

In this submenu you can view the RDM details of the device.

- 01) Press the **UP/DOWN** buttons to choose between the following options:
  - **UID**: the display shows the unique identification number of the device.  
The model ID for the Performer 1500 Fresnel Q6 is 0x29406B
  - **LABEL**: the display shows the name of the device
- 02) Press the **ENTER** button to confirm the selection.

## 6.6.11. CCT (Correlated Color Temperature Control)

In this menu you can calibrate the color temperature. This menu requires the **password**. The default password is pressing the **UP/DOWN** buttons in the following order: **UP, DOWN, UP, DOWN**.

- 01) Enter the password to access the menu.
- 02) Press the **ENTER** button to confirm the password.
- 03) Press the **UP/DOWN** buttons to scroll through the following options:

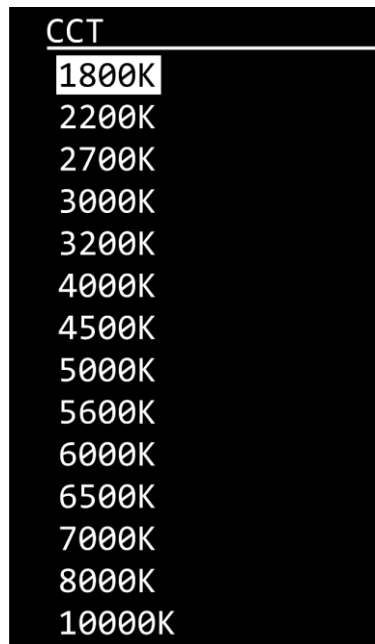

- 04) Press the **ENTER** button to confirm the selection.

### 6.6.12. Preset Color

In this menu you can choose a preset color mix.

01) Press the **UP/DOWN** buttons to select one of the 48 presets:



## 6.7. DMX Channels

### 6.7.1. 3 Channels, 8 Channels, 13 Channels, 20 Channels

3 CH (Basic)	8 CH (SSP)	13 CH (TOUR)	20 CH (TR16)	Function	Value	Setting
1	1	1	1	Master Dimmer	000-255	From low to high intensity (0-100 %)
			2	Dimmer Fine	000-255	From low to high intensity (0-100 %)
	2	2	3	Red	000-255	From low to high intensity (0-100 %)
			4	Red Fine	000-255	From low to high intensity (0-100 %)
	3	3	5	Green	000-255	From low to high intensity (0-100 %)
			6	Green Fine	000-255	From low to high intensity (0-100 %)
	4	4	7	Blue	000-255	From low to high intensity (0-100 %)
			8	Blue Fine	000-255	From low to high intensity (0-100 %)
	5	5	9	Amber	000-255	From low to high intensity (0-100 %)
			10	Amber Fine	000-255	From low to high intensity (0-100 %)
	6	6	11	Lime	000-255	From low to high intensity (0-100 %)
			12	Lime Fine	000-255	From low to high intensity (0-100 %)
	7	7	13	Cyan	000-255	From low to high intensity (0-100 %)
			14	Cyan Fine	000-255	From low to high intensity (0-100 %)
					000-010	No function
					011-015	Color 1
					016-020	Color 2
					021-025	Color 3
					026-030	Color 4
					031-035	Color 5
					036-040	Color 6
					041-045	Color 7
					046-050	Color 8
					051-055	Color 9
					056-060	Color 10
					061-065	Color 11
					066-070	Color 12
					071-075	Color 13
					076-080	Color 14
					081-085	Color 15
					086-090	Color 16
					091-095	Color 17
					096-100	Color 18
					101-105	Color 19
2		8	15	Color Presets	106-110	Color 20
					111-115	Color 21
					116-120	Color 22
					121-125	Color 23
					126-130	Color 24
					131-135	Color 25
					136-140	Color 26
					141-145	Color 27
					146-150	Color 28
					151-155	Color 29
					156-160	Color 30
					161-165	Color 31
					166-170	Color 32
					171-175	Color 33
					176-180	Color 34
					181-185	Color 35
					186-190	Color 36
					191-195	Color 37
					196-200	Color 38
					201-205	Color 39
					206-210	Color 40

3 CH (Basic)	8 CH (SSP)	13 CH (TOUR)	20 CH (TR16)	Function	Value	Setting	
					211-215	Color 41	
					216-220	Color 42	
					221-225	Color 43	
					226-230	Color 44	
					231-235	Color 45	
					236-240	Color 46	
					241-245	Color 47	
					246-250	Color 48	
					251-255	No function	
3		9	16	CCT	000-009	No function	
					010	1800 K	
					025	2200 K	
					040	2700 K	
					055	3000 K	
					070	3200 K	
					085	4000 K	
					100	4500 K	
					115	5000 K	
					130	5600 K	
					145	6000 K	
					160	6500 K	
					175	7000 K	
					190	8000 K	
205	10000 K						
255	10000 K						
		10	17	Auto Programs	000-040	No function	
					041-050	Auto 1	
					051-060	Auto 2	
					061-070	Auto 3	
					071-080	Auto 4	
					081-090	Auto 5	
					091-100	Auto 6	
					101-110	Auto 7	
					111-120	Auto 8	
					121-130	Auto 9	
					131-140	Auto 10	
					141-150	Custom program 1	Use Edit menu to manually set Time and Fade
					151-160	Custom program 2	
161-255	No Function						
		11	18	Speed	000-255	Program speed adjustment, from slow to fast	
8		12	19	Strobe	000-009	No function	
					010-099	Strobe, from low to high frequency (0-25 Hz)	
					100-109	No function	
					110-179	Lightning strobe, from low to high frequency (0-25 Hz)	
					180-189	No function	
					190-255	Random strobe, from low to high frequency (0-25 Hz)	
					255	No function	
		13	20	Control Mode	000-010	No Function	
					011-100	Reserved	
					101-110	Dimmer Off	
					111-120	Dimmer Mode 4	
					121-150	Reserved	
					151-160	1200 Hz	
					161-170	2400 Hz	
					171-180	4000 Hz	
					181-190	6000 Hz	
					191-200	25000 Hz	
					201-210	All Reset	
					211-255	Reserved	

**Note:** Make sure that the Master Dimmer channel is open in order to see the light output.

6.7.2. 7 Channels

7 CH (HSIC)	Function	Value	Setting
1	Intensity	000-255	From low to high intensity (0-100 %)
2	Hue	000-255	From low to high intensity (0-100 %)
3	Hue Fine	000-255	From low to high intensity (0-100 %)
4	Saturation	000-255	From low to high intensity (0-100 %)
5	CCT	000-009	No function
		010	1800 K
		025	2200 K
		040	2700 K
		055	3000 K
		070	3200 K
		085	4000 K
		100	4500 K
		115	5000 K
		130	5600 K
		145	6000 K
		160	6500 K
		175	7000 K
		190	8000 K
205	10000 K		
255	10000 K		
6	Strobe	000-009	No function
		010-099	Strobe, from low to high frequency (0-25 Hz)
		100-109	No function
		110-179	Lightning strobe, from low to high frequency (0-25 Hz)
		180-189	No function
		190-255	Random strobe, from low to high frequency (0-25 Hz)
7	Control Mode	000-010	No Function
		011-100	Reserved
		101-110	Dimmer Off
		111-120	Dimmer Mode 4
		121-150	Reserved
		151-160	1200 Hz
		161-170	2400 Hz
		171-180	4000 Hz
		181-190	6000 Hz
		191-200	25000 Hz
		201-210	All Reset
211-255	Reserved		

6.7.3. 10 Channels

10 CH (CMY)	Function	Value	Setting
1	Master Dimmer	000-255	From low to high intensity (0-100 %)
2	Cyan	000-255	From low to high intensity (0-100 %)
3	Magenta	000-255	From low to high intensity (0-100 %)
4	Yellow	000-255	From low to high intensity (0-100 %)
5	Color Presets	000-010	No function
		011-015	Color 1
		016-020	Color 2
		021-025	Color 3
		026-030	Color 4
		031-035	Color 5
		036-040	Color 6
		041-045	Color 7
		046-050	Color 8
		051-055	Color 9
		056-060	Color 10
		061-065	Color 11
		066-070	Color 12
		071-075	Color 13
		076-080	Color 14
		081-085	Color 15
		086-090	Color 16
		091-095	Color 17
		096-100	Color 18
		101-105	Color 19
		106-110	Color 20
		111-115	Color 21
		116-120	Color 22
		121-125	Color 23
		126-130	Color 24
		131-135	Color 25
		136-140	Color 26
		141-145	Color 27
		146-150	Color 28
		151-155	Color 29
		156-160	Color 30
		161-165	Color 31
		166-170	Color 32
		171-175	Color 33
		176-180	Color 34
		181-185	Color 35
		186-190	Color 36
		191-195	Color 37
		196-200	Color 38
		201-205	Color 39
		206-210	Color 40
		211-215	Color 41
		216-220	Color 42
		221-225	Color 43
		226-230	Color 44
		231-235	Color 45
236-240	Color 46		

10 CH (CMY)	Function	Value	Setting	
		241-245	Color 47	
		246-250	Color 48	
		251-255	No function	
6	CCT	000-009	No function	
		010	1800 K	
		025	2200 K	
		040	2700 K	
		055	3000 K	
		070	3200 K	
		085	4000 K	
		100	4500 K	
		115	5000 K	
		130	5600 K	
		145	6000 K	
		160	6500 K	
		175	7000 K	
		190	8000 K	
205	10000 K			
255	10000 K			
7	Auto Programs	000-040	No function	
		041-050	Auto 1	
		051-060	Auto 2	
		061-070	Auto 3	
		071-080	Auto 4	
		081-090	Auto 5	
		091-100	Auto 6	
		101-110	Auto 7	
		111-120	Auto 8	
		121-130	Auto 9	
		131-140	Auto 10	
		141-150	Custom program 1	Use Edit menu to manually set
		151-160	Custom program 2	Time and Fade
		161-255	No Function	
8	Speed	000-255	Program speed adjustment, from slow to fast	
9	Strobe	000-009	No function	
		010-099	Strobe, from low to high frequency (0-25 Hz)	
		100-109	No function	
		110-179	Lightning strobe, from low to high frequency (0-25 Hz)	
		180-189	No function	
		190-255	Random strobe, from low to high frequency (0-25 Hz)	
10	Control Mode	000-010	No Function	
		011-100	Reserved	
		101-110	Dimmer Off	
		111-120	Dimmer Mode 4	
		121-150	Reserved	
		151-160	1200 Hz	
		161-170	2400 Hz	
		171-180	4000 Hz	
		181-190	6000 Hz	
		191-200	25000 Hz	
		201-210	All Reset	
		211-255	Reserved	
		211-255	Reserved	

### 6.8. Supported RDM PIDs (Parameter IDs)

Parameter ID	Discovery command	SET command	GET command
DISC_UNIQUE_BRANCH	*		
DISC_MUTE	*		
DISC_UN_MUTE	*		
DEVICE_INFO			*
SUPPORTED_PARAMETERS			*
SOFTWARE_VERSION_LABEL			*
DMX_START_ADDRESS		*	*
IDENTIFY_DEVICE		*	*
DEVICE_MODEL_DESCRIPTION			*
MANUFACTURER_LABEL			*
DEVICE_LABEL		*	*
SENSOR_DEFINITION			*
SENSOR_VALUE		*	*
DEVICE_RESET		*	
DMX_PERSONALITY		*	
DMX_PERSONALITY_DESCRIPTION			*
STATUS_MESSAGES			*
STATUS_ID_DESCRIPTION			*



## 7. Troubleshooting

This troubleshooting guide contains solutions to problems which can be carried out by an ordinary person. The device does not contain user-serviceable parts.

Unauthorized modifications to the device will render the warranty void. Such modifications may result in injuries and material damage.

Refer servicing to instructed or skilled persons. Contact your Highlite International dealer in case the solution is not described in the table.

Problem	Probable cause(s)	Solution
The device does not function at all	No power to the device	<ul style="list-style-type: none"> <li>Check if power is switched on and cables are plugged in</li> </ul>
	Main fuse is blown	<ul style="list-style-type: none"> <li>Replace the fuse. See <b>8.3.1. Replacing the Fuse</b> on page 42</li> </ul>
The device responds erratically	The factory settings of the device are changed	<ul style="list-style-type: none"> <li>Reset the device's parameters to the default factory settings. See <b>6.6.9.1. Reset</b> on page 30</li> </ul>
The device does not respond to DMX control	The controller is not connected	<ul style="list-style-type: none"> <li>Connect the controller</li> </ul>
	The signal is reversed. The 5-pin DMX OUT of the controller does not match the DMX IN of the device	<ul style="list-style-type: none"> <li>Install a phase-reversing cable between the controller and the device</li> </ul>
	The controller is defective	<ul style="list-style-type: none"> <li>Try using another controller</li> </ul>
The device responds erratically to DMX control	Bad data link connection	<ul style="list-style-type: none"> <li>Examine connections and cables. Correct poor connections. Repair or replace damaged cables</li> </ul>
	The data link is not terminated with a 120 $\Omega$ termination plug	<ul style="list-style-type: none"> <li>Insert a termination plug in the DMX OUT connector of the last device on the link</li> </ul>
	Incorrect addressing	<ul style="list-style-type: none"> <li>Check address settings and correct, if necessary</li> </ul>
	In case of a setup with multiple devices, one of the devices is defective and disturbs data transmission on the link	<ul style="list-style-type: none"> <li>To find out the defective device, bypass one device at a time until normal operation is restored</li> </ul>
No light or LEDs cut out intermittently	LEDs are damaged	<ul style="list-style-type: none"> <li>Disconnect the device and contact your Highlite International dealer</li> </ul>
	The power supply settings do not match local AC voltage and frequency	<ul style="list-style-type: none"> <li>Disconnect the device. Check the settings and correct, if necessary</li> </ul>

## 8. Maintenance

### 8.1. Safety Instructions for Maintenance



**DANGER**  
Electric shock caused by dangerous voltage inside

Disconnect power supply before servicing or cleaning.



**WARNING**  
Risk of burns due to hot surface

Allow the device to cool down for at least 15 minutes before servicing or cleaning.

### 8.2. Preventive Maintenance



**Attention**  
Before each use, examine the device visually for any defects.

Make sure that:

- All screws used for installing the device or parts of the device are tightly fastened and are not corroded.
- The safety devices are not damaged.
- There are no deformations on housings, fixations and installation points.
- The lens is not cracked or damaged.
- The power cables are not damaged and do not show any material fatigue.

### 8.2.1. Basic Cleaning Instructions

The external lens of the device must be cleaned periodically in order to optimize the light output. The cleaning schedule depends on the conditions at the site where the device is installed. When smoke or fog machines are used at the site, the device will need more frequent cleaning. On the other hand, if the device is installed in well-ventilated area, it will need less frequent cleaning. To establish a cleaning schedule, examine the device at regular intervals during the first 100 hours of operation.

To clean the device, follow the steps below:

- 02) Disconnect the device from the electrical power supply.
- 03) Allow the device to cool down for at least 15 minutes.
- 04) Remove the dust collected on the external surface with dry compressed air and a soft brush.
- 05) Clean the lens with a damp cloth. Use a mild detergent solution.
- 06) Dry the lens carefully with a lint-free cloth.
- 07) Clean the DMX and other connections with a damp cloth.



#### Attention

- Do not immerse the device in liquid.
- Do not use alcohol or solvents.
- Make sure that the connections are fully dry before connecting the device to the power supply and to other devices.

### 8.3. Corrective Maintenance

The device does not contain user-serviceable parts. Do not open the device and do not modify the device.

Refer repairs and servicing to instructed or skilled persons. Contact your Highlite International dealer for more information.

#### 8.3.1. Replacing the Fuse



#### DANGER Electric shock caused by short-circuit

- Do not bypass the thermostatic switch or fuses.
- For replacement use fuses of the same type and rating only.

Power surges, short-circuit or incorrect electrical power supply may cause a fuse to burn out. If the fuse burns out, the device will not function anymore. If this happens, follow the steps below.

- 01) Disconnect the device from the electrical power supply.
- 02) Allow the device to cool down for at least 15 minutes.
- 03) Loosen the fuse cover with a screwdriver and remove the fuse holder.
- 04) If the fuse is brown or unclear, it is burned out. Remove the old fuse.
- 05) Insert a new fuse in the fuse holder. Make sure that the type and the rating of the replacement fuse are the same as the ones specified on the information label of the product.
- 06) Replace the fuse holder in the opening and tighten the fuse cover.

## 9. Deinstallation, Transportation and Storage

---

### 9.1. Instructions for Deinstallation



**WARNING**

**Incorrect deinstallation can cause serious injuries and damage of property.**

- Let the device cool down before dismantling.
- Disconnect power supply before deinstallation.
- Always observe the national and site-specific regulations during deinstallation and derigging of the device.
- Wear personal protective equipment in compliance with the national and site-specific regulations.

### 9.2. Instructions for Transportation

- Use the original packaging to transport the device, if possible.
- Always observe the handling instructions printed on the outer carton box, for example: "Handle with care", "This side up", "Fragile".

### 9.3. Storage

- Clean the device before storing. Follow the cleaning instructions in chapter **8.2.1. Basic Cleaning Instructions** on page 42.
- Store the device in the original packaging, if possible.

## 10. Disposal

---

### Correct disposal of this product

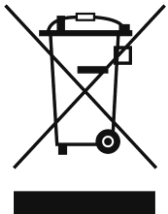

#### Waste Electrical and Electronic Equipment

This symbol on the product, its packaging or documents indicates that the product shall not be treated as household waste. Dispose of this product by handing it to the respective collection point for recycling of electrical and electronic equipment. This is to avoid environmental damage or personal injury due to uncontrolled waste disposal. For more detailed information about recycling of this product contact the local authorities or the authorized dealer.

## 11. Approval

---



Check the respective product page on the website of Highlite International ([www.highlite.com](http://www.highlite.com)) for an available declaration of conformity.









©2022 Showtec