

## LA108 and LA112 Active Line Array Loudspeakers

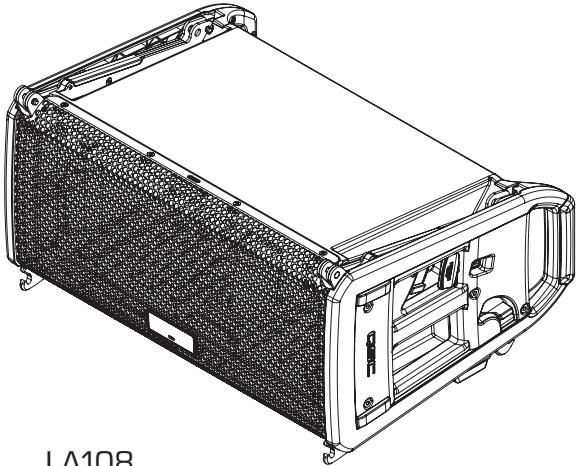

LA108

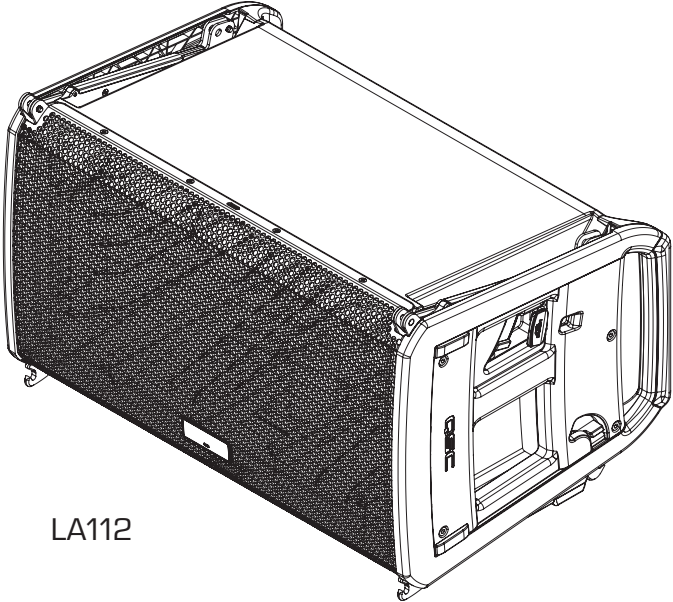

LA112

TD-001676-01-D



**L Class**

# Contents

Explanation Of Symbols . . . . .	5
Important Safety Instructions . . . . .	5
Rigging Safety Regulations: . . . . .	6
General Rules for Suspension . . . . .	6
Shock Loading . . . . .	7
Maximum Suspended Load . . . . .	7
FCC Statements . . . . .	7
LA108 Loudspeaker . . . . .	7
LA112 Loudspeaker . . . . .	8
Warranty . . . . .	8
Introduction . . . . .	9
Key Features and Technologies . . . . .	9
What's in the Box . . . . .	9
LA 108 Features . . . . .	10
LA112 Features . . . . .	11
LA108 and LA112 Deployment Options . . . . .	12
Ground Deployment (LA108 options shown) . . . . .	12
Flown Deployment (LA108 options shown) . . . . .	12
QSC RapidDeploy™ Rigging System . . . . .	13
Loudspeaker Attachment Points . . . . .	13
Loudspeaker Angle Controls . . . . .	13
Understanding Splay Angles . . . . .	14
Progressive Splay Angle Rule . . . . .	14
How to Manually Total Array Angles . . . . .	15
Ground Deployment . . . . .	16
Pole Mounted on a Tripod Stand . . . . .	16
LA108 Loudspeaker . . . . .	16
LA112 Loudspeaker . . . . .	16
Pole Mounting a Loudspeaker to a Tripod . . . . .	16
Stacking an Array on a Tripod Pole Mount . . . . .	17
Splay Angle Adjustment on a Tripod Mount . . . . .	17
Decreasing Angle . . . . .	18
Increasing Angle . . . . .	18
Pole Mounted Over a Subwoofer(s) . . . . .	18
LA108 Loudspeaker . . . . .	18
LA112 Loudspeaker . . . . .	20
Pole Mounting a Loudspeaker over a Subwoofer(s) . . . . .	21
Stacking an Array on a Pole Mount over a Subwoofer(s) . . . . .	21
Splay Angle Adjustment on a Pole Mount over a Subwoofer(s) . . . . .	22
Decreasing Angle . . . . .	22
Increasing Angle . . . . .	22

Stacking over a Subwoofer(s) .....	23
LA108 Loudspeaker .....	23
LA112 Loudspeaker .....	23
Attaching an Array Frame and Stack Adapter Kit to a Subwoofer .....	24
Attaching a Loudspeaker to a Subwoofer .....	25
Detaching a Loudspeaker from a Subwoofer .....	26
Stacking an Array of Loudspeakers on a Subwoofer .....	26
Splay Angle Adjustment for a Subwoofer Stack .....	27
Decreasing Angle .....	27
Increasing Angle .....	27
Front Fill (Stage-Lip) .....	27
Ground Stack .....	28
Preparing an Array Frame and Stack Adapter Kit for a Ground Stack .....	28
Attaching a Loudspeaker to an Array Frame for a Ground Stack .....	29
Detaching a Loudspeaker from an Array Frame for a Ground Stack .....	29
Stacking an Array of Loudspeakers for a Ground Stack .....	29
Splay Angle Adjustment for Ground Stack .....	30
Decreasing Angle .....	30
Increasing Angle .....	31
Horizontal Array .....	31
Stacked Horizontal Array .....	32
Splay Angle Adjustment for Stacked Horizontal Array .....	33
Detaching Loudspeakers from a Stacked Horizontal Array .....	33
Flown Deployment .....	34
Flown Deployment with an Array Frame .....	34
Array Frame Pre-Assembly .....	34
Array Frame Attachment Preparation .....	34
Attaching a Loudspeaker to the Array Frame .....	34
Attaching Loudspeakers for an Array .....	35
Detaching Loudspeakers from an Array .....	35
Detaching a Loudspeaker from the Array Frame .....	36
Splay Angle Adjustment for Flown Deployment .....	36
Decreasing Angle .....	36
Increasing Angle .....	36
Pick-Point Deployment .....	37
Single Pick-Point Deployment .....	37
Bridle Deployment .....	37
Adjusting the Tilt Angle of the Array on a Pick-Point Deployment .....	37
Optional Eyebolt .....	37
Rear Panel Connections .....	38
System Power .....	38
AC Mains Connections .....	39
Connecting to AC Mains .....	39
Daisy-Chaining with Power Cable Jumpers .....	39
Compatible QSC Accessories .....	39
Daisy-Chaining Procedure .....	40

Recommended Configurations .....	40
LA108 Loudspeaker .....	40
LA112 Loudspeaker .....	40
Power On Sequence .....	41
Power Off Sequence .....	41
Analog Audio Connections .....	41
XLR Connections .....	41
Daisy-Chaining with Balanced XLR Jumper Cables .....	42
Network Connections .....	42
Daisy-Chaining with Network Jumper Cables .....	42
Connecting to a Network .....	43
Network Control .....	43
Dante® Audio Setup .....	43
Cooling .....	43
Outdoor Installations .....	44
Rear Panel User Interface .....	44
Navigating the Rear User Interface .....	44
Menu Map .....	44
Home Screen .....	45
Home Screen Status .....	45
Top Bar .....	45
Network Icon .....	46
Ar-Q™ (Array Equalization) .....	46
High-Pass Filter .....	46
EQ .....	46
Menu .....	46
Settings .....	47
Utilities .....	47
Additional Functions .....	47
DSP Features .....	48
L Class Accessories .....	48
Transportation .....	48
Interconnect Jumpers .....	48
Between Loudspeakers .....	48
Temporary Outdoor Use .....	49
Sub-stacking .....	49
LA108 Loudspeaker .....	49
LA112 Loudspeaker .....	49
Flown (Portable or Installed) .....	49
Flown (Installed Only) .....	49
Additional Information .....	49
Care and Maintenance .....	49
QSC Self Help Portal .....	50
Customer Support .....	50
Warranty .....	50

# EXPLANATION OF SYMBOLS

The term "WARNING!" indicates instructions regarding personal safety. If the instructions are not followed, the result may be bodily injury or death.

The term "CAUTION!" indicates instructions regarding possible damage to physical equipment. If these instructions are not followed, it may result in damage to the equipment that may not be covered under the warranty.

The term "IMPORTANT!" indicates instructions or information that are vital to the successful completion of the procedure.

The term "NOTE" is used to indicate additional useful information.



**NOTE:** The intent of the lightning flash with arrowhead symbol in a triangle is to alert the user to the presence of un-insulated "dangerous" voltage within the product's enclosure that may be of sufficient magnitude to constitute a risk of electric shock to humans.



**NOTE:** The intent of the exclamation point within an equilateral triangle is to alert the user to the presence of important safety, and operating and maintenance instructions in this manual.



## IMPORTANT SAFETY INSTRUCTIONS



**WARNING!:** TO PREVENT FIRE OR ELECTRIC SHOCK, DO NOT EXPOSE THIS EQUIPMENT TO RAIN OR MOISTURE.



**WARNING!:** Before placing, installing, rigging, or suspending any loudspeaker product, inspect all hardware, suspension, cabinets, transducers, brackets and associated equipment for damage. Any missing, corroded, deformed, or non-load rated component could significantly reduce the strength of the installation or placement. Any such condition severely reduces the safety of the installation and should be immediately corrected. Use only hardware which is rated for the loading conditions of the installation and any possible short-term, unexpected overloading.

Never exceed the rating of the hardware or equipment.

Consult a licensed, professional engineer regarding physical equipment installation. Ensure that all local, state and national regulations regarding the safety and operation of loudspeakers and related equipment are understood and adhered to.



**WARNING!:** The LA108 weighs 13.7 kg (30.1 lb), and the LA112 weighs 21.4 kg (47.2 lb). Use proper precautions when lifting or moving.

During assembly and disassembly, make sure the loudspeakers are properly, physically supported throughout the entire process.

While it is possible for one person to lift a LA108 or LA112 loudspeaker, it is important to use proper lifting techniques. Suggested reading: OSHA Technical Manual on Back Disorders and Injuries.

([http://www.osha.gov/dts/osta/otm/otm\\_vii/otm\\_vii\\_1.html#app\\_vii:1\\_2](http://www.osha.gov/dts/osta/otm/otm_vii/otm_vii_1.html#app_vii:1_2)).

1. Keep these instructions.
2. Heed all warnings.
3. Follow all instructions.
4. Do not use this apparatus near water.
5. Clean only with a dry cloth.
6. Install in accordance with the manufacturer's instructions.
7. Do not install near any heat sources such as radiators, heat registers, stoves, or other apparatus (including amplifiers) that produce heat.

8. This apparatus shall not be exposed to dripping or splashing water, and no object filled with liquids such as cups or vases shall be placed on the apparatus.
9. To reduce the risk of electric shock, the power cord shall be connected to a mains socket with a protective earthing connection.
10. Protect the power cord from being walked on or pinched, particularly at plugs, convenience receptacles, and the point where they exit from the apparatus.
11. Only use attachments/accessories specified by the manufacturer.
12. Unplug this apparatus during lightning storms or when unused for long periods of time.
13. Refer all servicing to qualified service personnel. Servicing is required when the apparatus has been damaged in any way, such as when the power-supply cord or plug is damaged, liquid has been spilled or objects have fallen into the apparatus, and/or the apparatus has been exposed to rain or moisture, does not operate normally, or has been dropped.
14. The appliance coupler (AC Mains plug) is the AC mains disconnect device and shall remain readily operable after installation.
15. Adhere to all applicable, local codes.
16. Consult a licensed, professional engineer when any doubt or questions arise regarding a physical equipment installation.
17. Suspension of this product should be done by qualified persons following safe rigging practices. Other limitations may apply.
18. Use only the recommended system components and suspension hardware intended for use with this product as directed by this manual.

## Rigging Safety Regulations:

- 2006/42/EC
- EN ISO 12100-1: 2004
- EN 1991-1 / EN 1993-1-1 / EN 1993-1-8 / EN 1999-1-1
- DGUV Vorschrift 17/18
- ANSI E1.8-2018

## General Rules for Suspension

- Consult a professional mechanical or structural engineer, licensed in the jurisdiction of the sound system installation, to review, verify, and approve all attachments to the building or structure.
- Employ the services of a certified, professional rigger for hoisting, positioning, and attaching the equipment to the supporting structure.
- Correct use of all suspension hardware and components is imperative in sound system suspension and deployment.
- Always calculate suspended loads before lifting to ensure suspension components and hardware are used within their respective load limits.
- Consult local codes and regulations to fully understand the requirements for suspended loads in the venue in which equipment will be suspended.
- Use only dedicated QSC LA108-AF and/or QSC LA112-AF array frames or the QSC LA-KIT-I installation kit for suspending a loudspeaker array. Further details can be found below.
- Be absolutely certain of the integrity of any structural member intended to support suspended loads. Hidden structural members can have hidden structural weakness.
- Never assume anything! Owner or third-party supplied suspension attachment points may not be adequate for suspending the loads.
- Before lifting, always inspect all components (enclosures, suspension brackets, pins, frames, bolts, nuts, slings, shackles, etc.) for cracks, wear, deformation, corrosion, missing, loose, or damaged parts that could reduce the strength of the assembly. Discard any worn, defective, or suspect parts and replace them with new, appropriately load-rated parts.

# Shock Loading

When a load is moved or stopped, its static weight is magnified. Sudden movements can magnify the static weight several times. This is called "shock loading."

The effects of shock loading can be instantaneous, or it can remain undetected. Proper preparation for shock loading requires careful planning and knowledge of equipment, suspension, and lifting practices. Shock loading is most often the result of lifting and installation, but natural forces (winds, earthquakes, etc.) can create shock loads several times the static load.

Shock loading poses a danger to equipment and workers. Because of this, structures and suspension equipment must be capable of supporting several times the weight of the suspended equipment.

# Maximum Suspended Load

The following table provides Working Load Limits (WLL) at varying Safety Factors (7:1, 10:1, or 12:1) for the LA108 and LA112 active line array loudspeakers and companion rigging accessories.

The data presented below is based upon the listed component weights. The tabulated Working Load Limits represent static loads only. Dynamic and shock-load conditions are determined by unknown, installation-specific factors. The choice of which Safety Factor to follow will depend upon the jurisdiction, venue of installation, and conditions of suspension.

Refer to a Licensed Structural Engineer for clarification before proceeding with suspension.

Working Load Limits				
Model	Individual Component Weight	7:1 Safety Factor	10:1 Safety Factor	12:1 Safety Factor
LA108	13.7 kg / 30.1 lb	241.3 kg / 532 lb	169.2 kg / 373 lb	140.6 kg / 310 lb
LA108 M10 Pullback Point	Built into rear of product	92.1 kg / 203 lb	64.4 kg / 142 lb	53.5 kg / 118 lb
LA112	21.4 kg / 47.2 lb	235.4 kg / 519 lb	178.4 kg / 378 lb	149.6 kg / 330 lb
LA112 M10 Pullback Point	Built into rear of product	80.3 kg / 177 lb	56.2 kg / 124 lb	46.7 kg / 103 lb
LA108-AF	10.7 kg / 23.7 lb	234.9 kg / 518 lb	164.6 kg / 363 lb	126.1 kg / 278 lb
LA112-AF	11.5 kg / 25.4 lb	235.8 kg / 520 lb	165.1 kg / 364 lb	137.4 kg / 303 lb
LA-KIT-I*		4 LA108		3 LA112

\* Included bridled angle to be 90° or less.

# FCC Statements

## LA108 Loudspeaker



**NOTE:** The LA108 active line array loudspeaker has been tested and found to comply with the limits for a Class B digital device, pursuant to Part 15 of the FCC Rules.

These limits are designed to provide reasonable protection against harmful interference in a residential installation. This equipment generates, uses, and can radiate radio frequency energy. If not installed and used in accordance with the instructions, it may cause harmful interference to radio communications. However, there is no guarantee that interference will not occur in a particular installation. If this equipment does cause harmful interference to radio or television reception, which can be determined by turning the equipment off and on, the user is encouraged to try to correct the interference by one or more of the following measures:

- Reorient or relocate the receiving antenna.
- Increase the separation between the equipment and receiver.
- Connect the equipment into an outlet on a circuit different from that to which the receiver is connected.
- Consult the dealer or an experienced radio/TV technician for help.

## LA 112 Loudspeaker



**NOTE:** The LA 112 active line array loudspeaker has been tested and found to comply with the limits for a Class A digital device, pursuant to part 15 of the FCC Rules.

These limits are designed to provide reasonable protection against harmful interference when the equipment is operated in a commercial environment. This equipment generates, uses, and can radiate radio frequency energy. If not installed and used in accordance with the instruction manual, it may cause harmful interference to radio communications. Operation of this equipment in a residential area is likely to cause harmful interference in which case the user will be required to correct the interference at his own expense.

## Warranty

For a copy of the QSC Limited Warranty, visit the QSC website at [www.qsc.com](http://www.qsc.com).



**NOTE:** Read and follow these instructions carefully. If the loudspeakers are not suspended properly, they could fall, causing personal injury and damage to the equipment. Please refer to the Flown Deployment chapter of the User Manual for rules on suspension.



# Introduction



L Class represents the next generation of advanced, intelligent, active loudspeakers for applications ranging from simple, portable, plug-and-play setups, to demanding, networked, high-tech AV productions and fixed installations.

The LA108 and LA112 are active line array loudspeakers featuring a brilliant combination of leading-edge innovation, refined engineering, and unparalleled ease of use in easy-to-deploy packages.

## Key Features and Technologies

- Purpose-designed, lightweight neodymium transducers deliver high, undistorted SPL (134 dB / 136 dB peak).
- Energy efficient Class D amplifier modules (1300 W / 2400 W peak power) with Power Factor Correction and extremely low AC consumption.
- Innovative QSC LEAF™ (Length-Equalized Acoustic Flare) waveguide provides defined, uniform coverage and exceptional throw.
- Acoustic Linear Phase (ALP) design provides complementary coherence between QSC loudspeakers deployed in the same audio system delivering a uniform listening experience across the entire venue.
- Intuitive, single operator QSC RapidDeploy™ rigging technology with short, medium, and long-throw options guarantees fast deployment without tools or additional hardware.
- Onboard QSC AWARE™ (Automatic Wireless Array Recognition) system intelligence communicates essential setup information to the user via any loudspeaker’s Rear User Interface (RUI) or QSC System Navigator™ App.
- Ar-Q™ (Array Equalization) processing automatically makes the appropriate equalization adjustments based on the total splay angle of the array, total number of boxes in the array, and the location of each loudspeaker in the array.
- QSC SysNav™ (System Navigator) App allows the user to easily design, configure, control, monitor and apply signal processing to individual loudspeakers, full arrays, or groupings of both.
- Network solution includes digital audio-over-IP (Dante®) for interoperability with other audio equipment and seamless control and monitoring integration into the Q-SYS Ecosystem via Q-SYS Inventory Extensions.
- Flown, ground-stacked over subwoofer(s), loudspeaker stand/pole mounted, or horizontal ground deployment options.

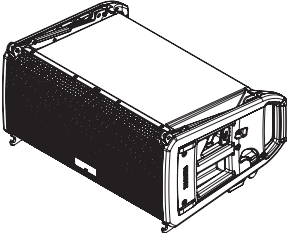
## What’s in the Box

	<p>(1) LA108/LA112 active line array loudspeaker unit</p>	<p>(1) AC power cord, with PowerCON® TRUE1 (3 m / 10 ft) connectors</p>
	<p>(1) Quick Start Guide</p>	 <p>(1) Safety Sheet TD-001655-00</p>

# LA108 Features

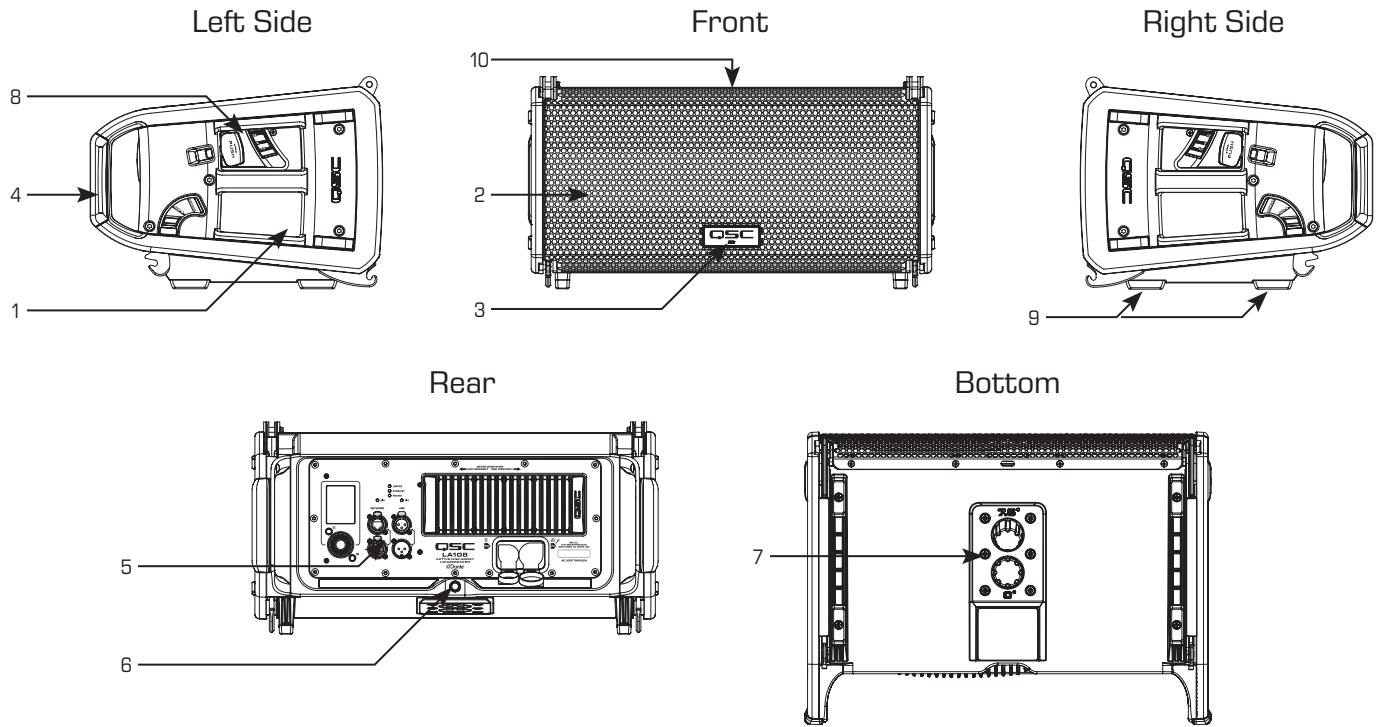

— Figure 1 —

1. ABS enclosure
2. Steel grille
3. Front power LED
4. Handles
5. Rear panel with amplifier module, connectors and rear user interface
6. M10 pull back point
7. Dual-angle, 35 mm pole socket (0° or -7.5°)
8. Side rigging panel
9. Slip-resistant feet
10. IR communication windows

# LA 112 Features

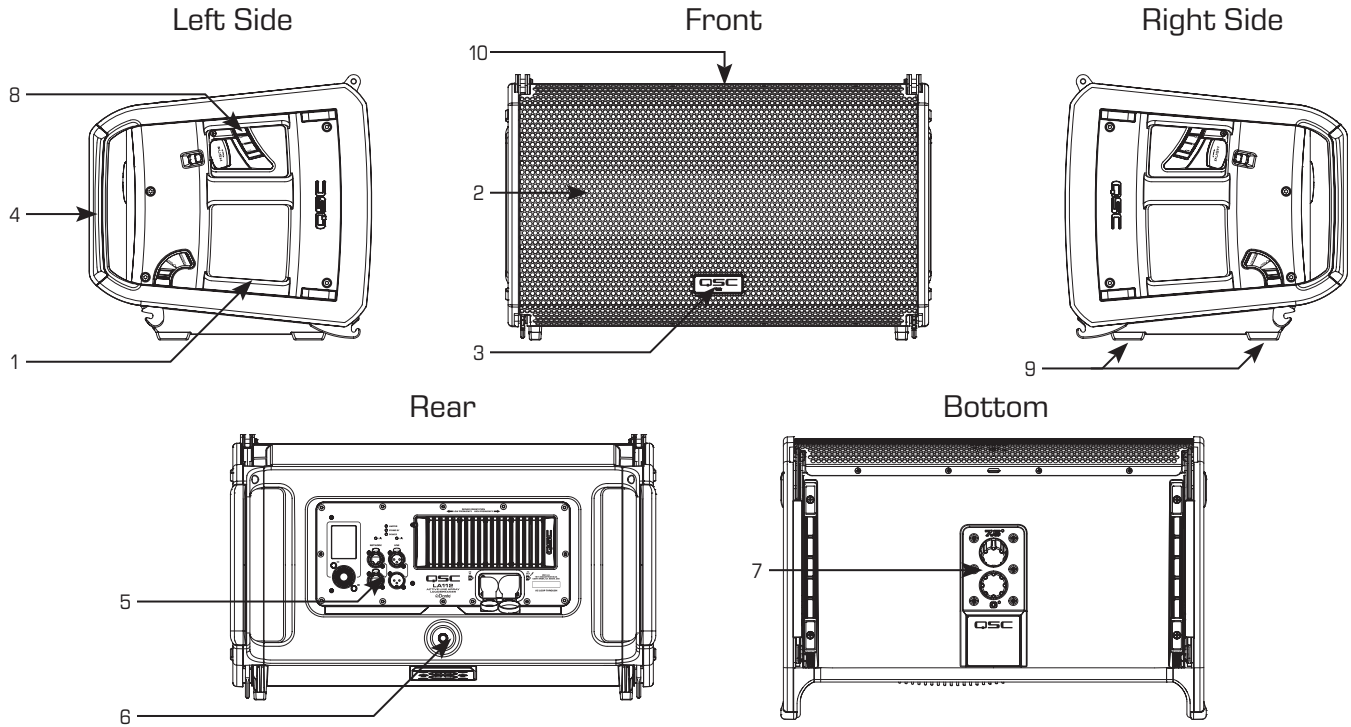

— Figure 2 —

1. ABS enclosure
2. Steel grille
3. Front power LED
4. Handles
5. Rear panel with amplifier module, connectors and rear user interface
6. M10 pull back point
7. Dual-angle, 35 mm pole socket (0° or -7.5°)
8. Side rigging panel
9. Slip-resistant feet
10. IR communication windows

# LA108 and LA112 Deployment Options

## Ground Deployment (LA108 options shown)

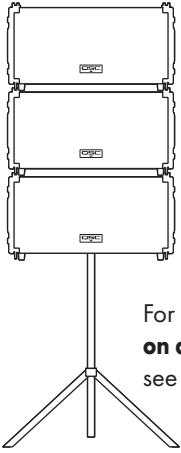

For **Pole Mounted on a Tripod Stand** see page 16.

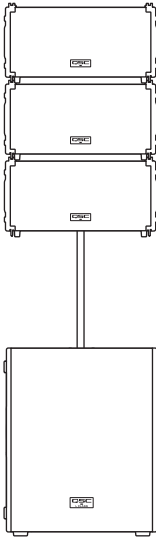

For **Pole Mounted Over a Subwoofer(s)** see page 18.

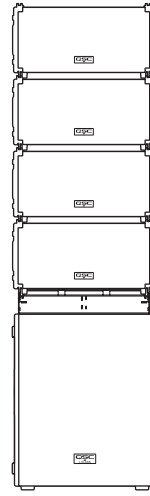

For **Stacking over a Subwoofer(s)** see page 23.

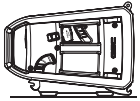

For **Front Fill (Stage-Lip)** see page 27.

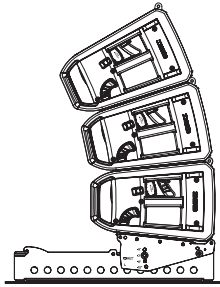

For **Ground Stack** see page 28.

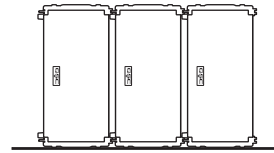

For **Horizontal Array** see page 31.

## Flown Deployment (LA108 options shown)

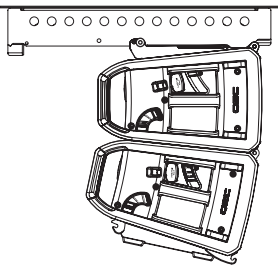

For **Flown Deployment with an Array Frame** see page 34.

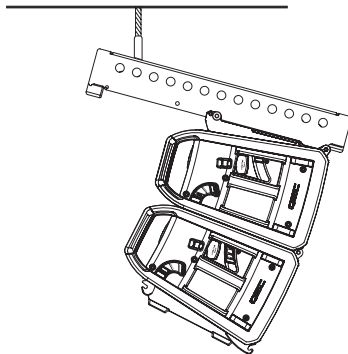

For **Pick-Point Deployment** see page 37.

# QSC RapidDeploy™ Rigging System

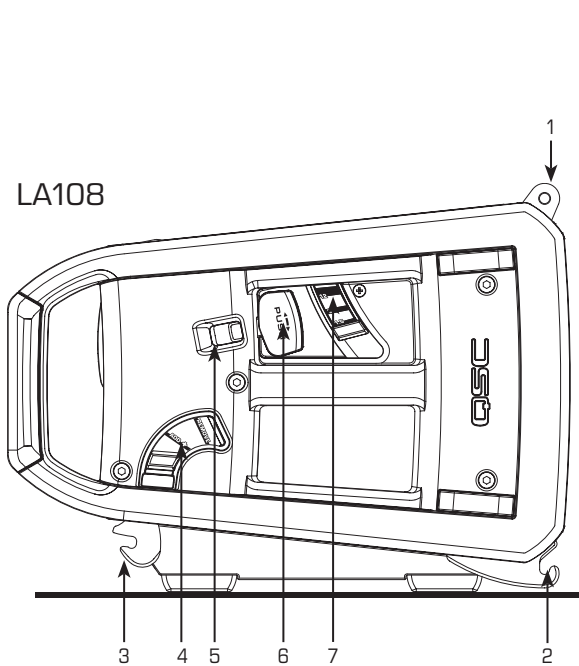

— Figure 3 —

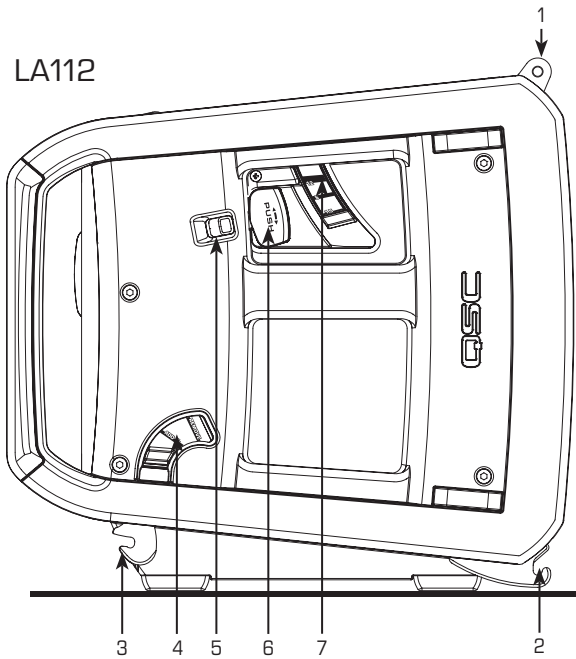

— Figure 4 —

## Loudspeaker Attachment Points

1. Front Strikes attach to Front Hooks of the loudspeaker or ground stack above it.
2. Front Hooks attach to Front Strikes of the loudspeaker or ground stack adapter below it.
3. Rear Hooks attach loudspeaker at the rear. They are the locking points once two or more enclosures are arrayed together or ground stacked.
4. The Locking Lever has three positions:
  - Up: Release loudspeaker from the array
  - Middle: Prepare loudspeaker to be secured
  - Down: Lock attached loudspeaker in place

## Loudspeaker Angle Controls

5. The Angle Lever Reset will release a depressed Angle Lever without adjusting the Angle Bar.
6. The Angle Lever prepares the Angle Bar (7) to move to the next available angle. The Angle Lever must return to the full outward position after angle adjustment. An internal pin locks the Angle Bar when the lever is in the full outward position. If necessary, move the Angle Bar, and/or push the Angle Lever Reset (5) to set the Angle Bar position.
7. The Angle Bar Lift offers manual lifting of the Angle Bar and visual representation of the splay angle setting (Up: 1.5°, Middle: 6°, Down: 12°). Note that the Angle Bar is raised in the LA108 and lowered in the LA112 in the images above.

# Understanding Splay Angles

QSC RapidDeploy™ features a unique Angle Bar with an internal pin mechanism that provides three selectable splay angle adjustments. These adjustments allow the user to create custom array shapes based on the venue size and application. These three splay angles are:

- 1.5 degrees - This smaller splay angle setting provides maximum high frequency coupling between adjacent boxes, delivering the greatest throw:



— Figure 5 —

- In a 2-box array this smaller splay angle setting is ideally suited for large venues or temporary outdoor applications.

- In a taller 3-6 box array, this smaller splay angle setting should always be used at the top of the array, which is typically aimed towards the rear-most section of the audience.

- 6 degrees - This medium splay angle setting provides less high frequency coupling between adjacent boxes, delivering a moderate throw:



— Figure 6 —

- In a 2-box array this medium splay angle setting is ideally suited for mid-sized venues.

- In a taller 3-6 box array, this medium splay angle setting acts as a coverage transition and should always be in the center of the array, which is typically aimed towards the middle section of the audience.

- 12 degrees - This larger splay angle setting provides minimal high frequency coupling between adjacent boxes, delivering a reduced throw:

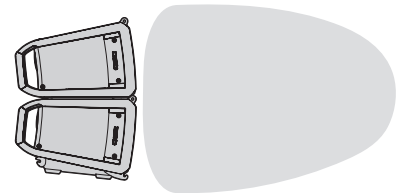

— Figure 7 —

- In a 2 box array this large splay angle setting is ideally suited for small venues or clubs.
- In a taller 3-6 box array, this large splay angle setting should be used at the very bottom of the array, which is typically aimed towards the front-most section of the audience.

## Progressive Splay Angle Rule

A larger splay angle value can NOT be used above a smaller splay angle value, as this will result in an unsupported loudspeaker array that cannot be optimized. The splay angle values must either match or progressively increase in size from the top of the array to the bottom. Here is an example of a supported array versus an unsupported array:

**NOTE:** Although it is technically possible to deploy and use the array using any splay angle combination, which does not follow the Progressive Splay Angle Rule, QSC does not recommend those deployments.

In such cases, the Ar-Q™ Array Equalization and individual loudspeaker EQ can be manually set to taste. In that process, QSC recommends setting all line array loudspeakers to a single loudspeaker voicing because using multiple array equalization settings may cause undesired acoustic results.

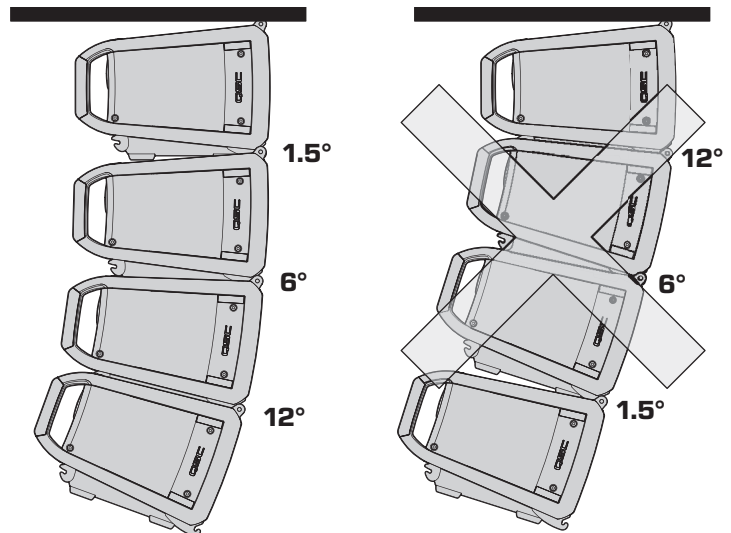

— Figure 8 —

## How to Manually Total Array Angles

When hung in an array, loudspeakers require specific EQs to ensure the array functions properly as a single sound source. The total splay angle of the array is used in part to create the filter set to make it acoustically accurate. When the array is optimized, the Ar-Q™ Array Equalization DSP relays the total splay angle of the array through infrared communication between the loudspeakers.

In the unlikely event that the infrared stops communicating on one loudspeaker, or when using a deployment that is unsupported by the Ar-Q™ optimization (for example, an array of seven or more loudspeakers), line array voicings can be set manually from the loudspeaker's Rear User Interface to achieve optimum performance.

To do this, users must calculate the total angle splay BETWEEN loudspeakers in the deployed array and enter that calculation into the DSP to get the correct loudspeaker EQ settings.

**NOTE:** Do not count the angle between the Array Frame or the Sub Stack Adapter.

**NOTE:** See the section for "Navigating the Rear User Interface" to access AR-Q™ settings.

Example 1: If an array consists of three (3) loudspeakers deployed with a splay angle of 1.5° between the top and the middle loudspeaker, and 6° between the middle and the bottom loudspeaker, then the total splay angle is 1.5 + 6, which is 7.5 (See graphic below).

Example 2: If an array consists of six (6) loudspeakers, deployed with a splay angle of 1.5° from the first to the second loudspeaker, 1.5° from the second to the third loudspeaker, 6° from the third to the fourth loudspeaker, 6° from the fourth to the fifth loudspeaker, and 12° from the fifth to the sixth loudspeaker, then the total splay angle is 1.5 + 1.5 + 6 + 6 + 12, which is 27 (See graphic below).

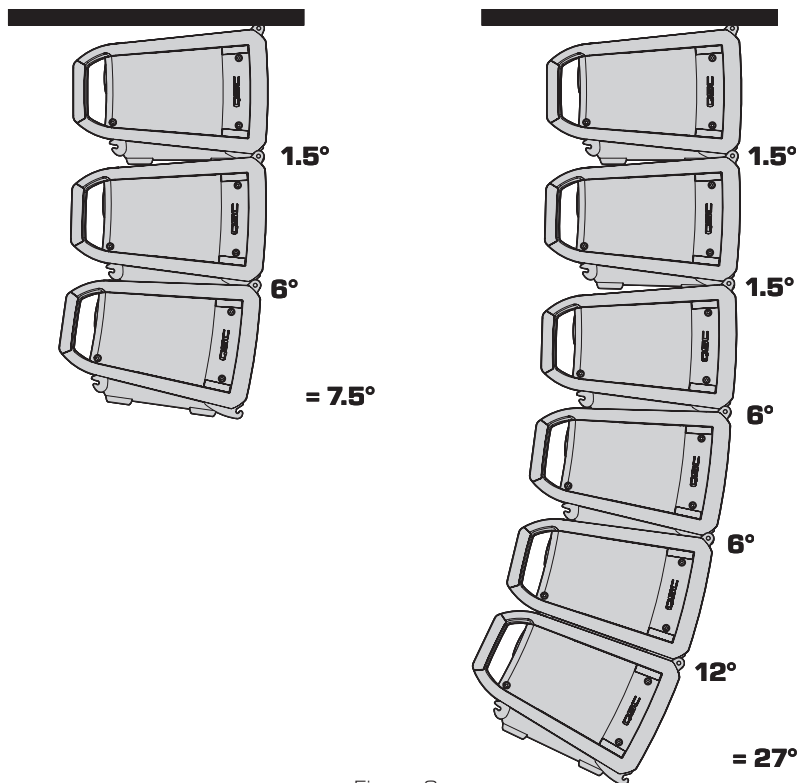

— Figure 9 —

# Ground Deployment

## Pole Mounted on a Tripod Stand

Both LA108/LA112 active line array loudspeakers feature dual 35 mm pole sockets to accommodate either 0° or -7.5° downward tilt of the enclosure to optimize audience coverage wherever deployed.



**WARNING!** Due to the large selection of various types of tripod stands available in the market, QSC cannot recommend a maximum deployment height. Assessment of the safety of each individual deployment is left to the user. However, any tripod stands used must be properly rated for the deployment.



**WARNING!** When deploying loudspeakers on poles, additional attention should be given to account for environmental conditions such as level surfaces, level materials, vibrations, wind, etc, to deploy the loudspeakers in a stable and safe manner. Use additional measures to secure the loudspeaker pole (not included) when necessary.

### LA108 Loudspeaker

Up to three (3) LA108 loudspeakers may be mounted on a 45 kg (100 lb) rated tripod loudspeaker stand.

### LA112 Loudspeaker

Up to two (2) LA112 loudspeakers may be mounted on a 45 kg (100 lb) rated tripod loudspeaker stand.

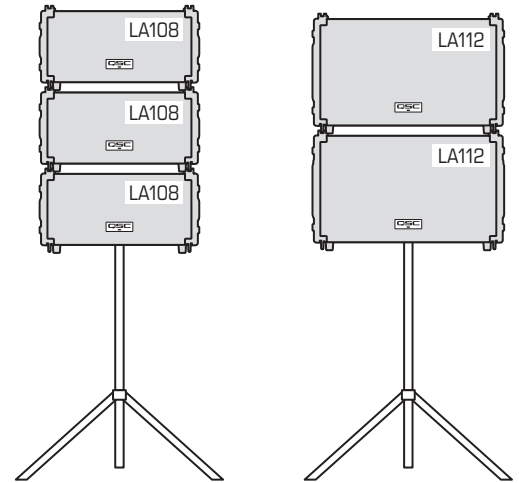

— Figure 10 —

### Pole Mounting a Loudspeaker to a Tripod

To deploy a pole mount with a tilt of 0° or -7.5°, mount the loudspeaker on a 45 kg (100 lb) rated tripod loudspeaker stand using the 35 mm pole socket labeled 0° or -7.5° on the bottom of the loudspeaker.

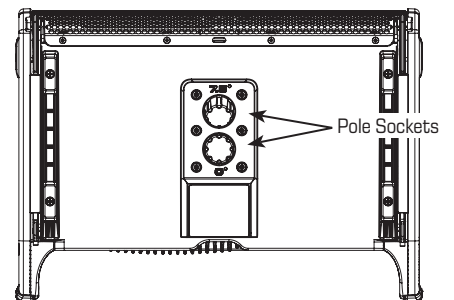

— Figure 11 —



## Stacking an Array on a Tripod Pole Mount

1. After securing the first loudspeaker to the pole, set the Locking Levers on both sides of the new loudspeaker to the middle (ADD+) position.
2. Hook both Front Strikes of the new loudspeaker onto the Front Hooks of the loudspeaker mounted to the pole.
3. Lower the back side of the loudspeaker until the new loudspeaker connects with the loudspeaker mounted to the pole, making a click sound.
4. Push Locking Levers down (LOCK) to secure the new loudspeaker on both sides.
5. Repeat steps 1-4, until array is complete.

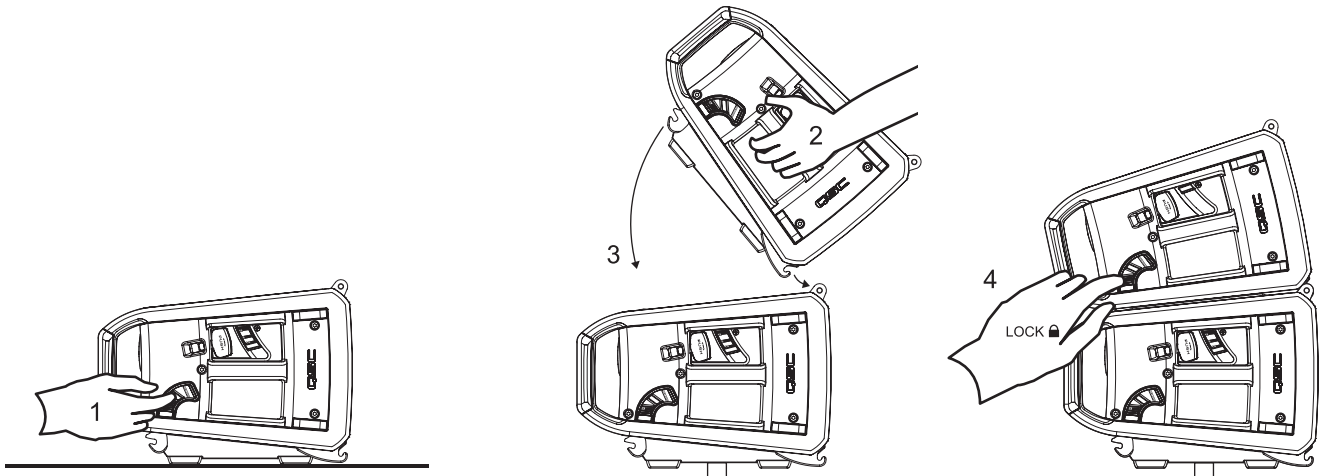

— Figure 12 —

## Splay Angle Adjustment on a Tripod Mount

Along with the 0° and -7.5° angle options on a pole mount, splay angle of individual loudspeakers can be adjusted further to 1.5°, 6°, and 12°.

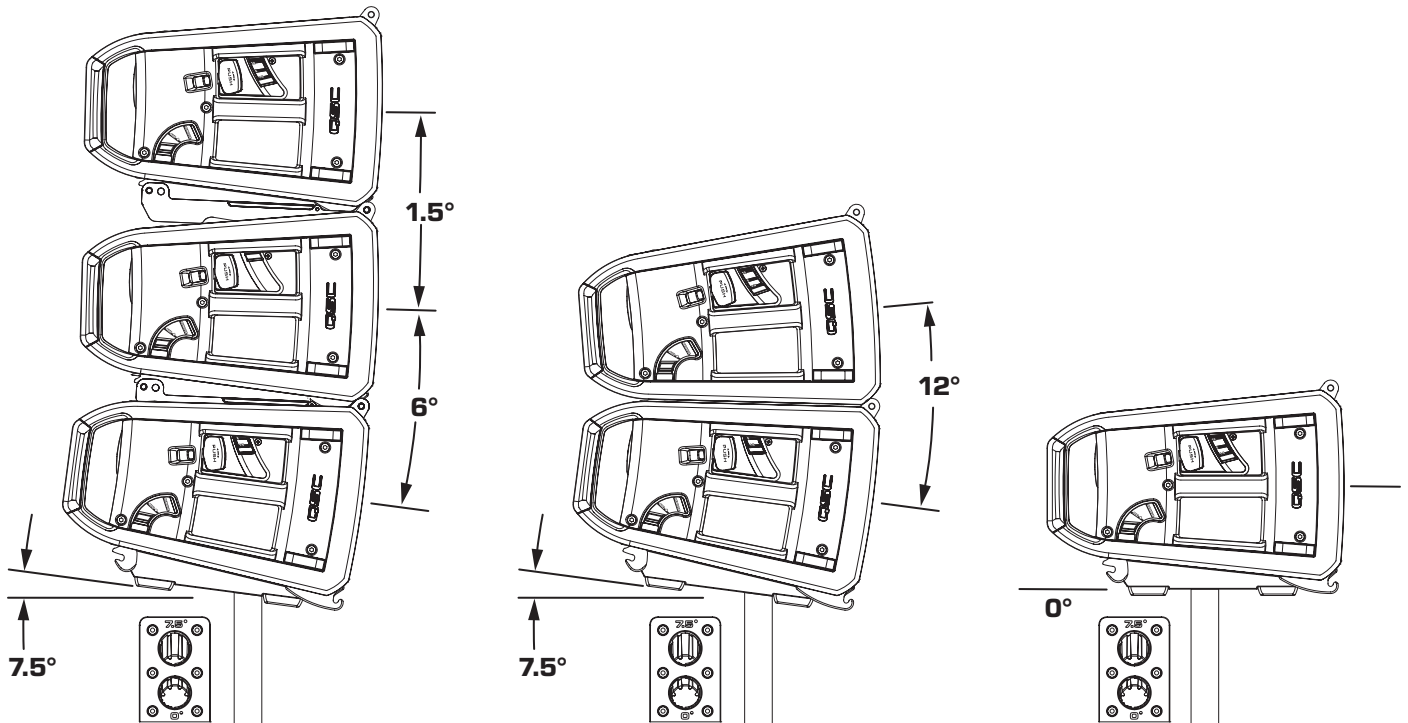

— Figure 13 —

**NOTE:** See the section on “Understanding Splay Angles” for further details.

## Decreasing Angle

1. Push Angle Lever on both sides all the way in, until they make a click sound and stay depressed.
2. Lift loudspeaker up into the next angle position, until it makes a click sound.

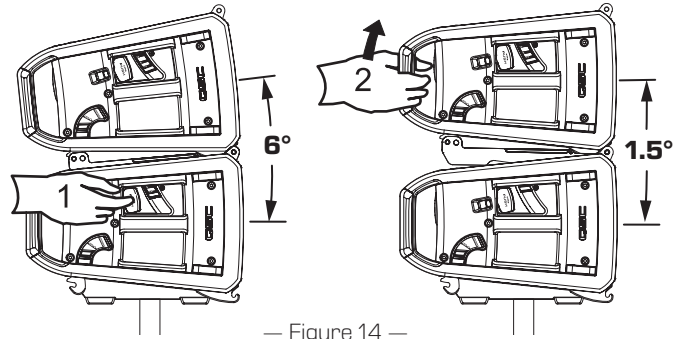

— Figure 14 —

## Increasing Angle

1. Push Angle Lever on both sides all the way in, until they make a click sound and stay depressed.
2. Slightly lift loudspeaker weight to release internal pin.
3. Lower loudspeaker into the next angle position, until it makes a click sound.

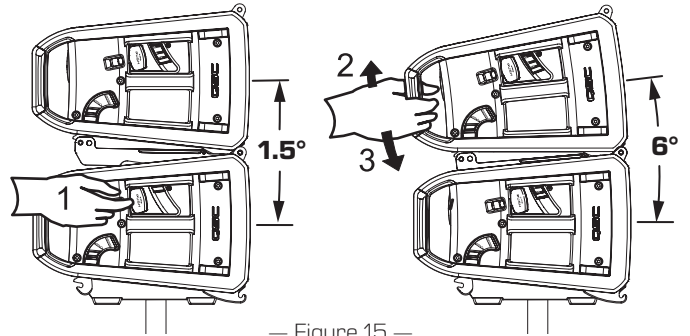

— Figure 15 —

## Pole Mounted Over a Subwoofer(s)

### LA108 Loudspeaker

Three (3) LA108 loudspeakers can be safely pole-mounted using a QSC threaded subwoofer pole over:

- a. one (1) LS118/KS118 subwoofer when the subwoofer is upright, or
- b. two (2) LS118/KS212C when the subwoofers are rotated on their side.

In the above configurations, the subwoofer pole should be no longer than 66 cm (26 inches). The QSC SP-26 accessory (sold separately) is suitable for this task.

If two (2) LA108 loudspeakers are pole-mounted using a QSC threaded subwoofer pole (QSC SP-36 accessory sold separately), then the subwoofer pole length can be safely increased to 91 cm (36 inches) in the configurations in on the next page.



**WARNING!:** Longer pole lengths should not be used, unless the subwoofer is securely attached to the ground with additional straps or hardware (not included) to prevent a tipping hazard.

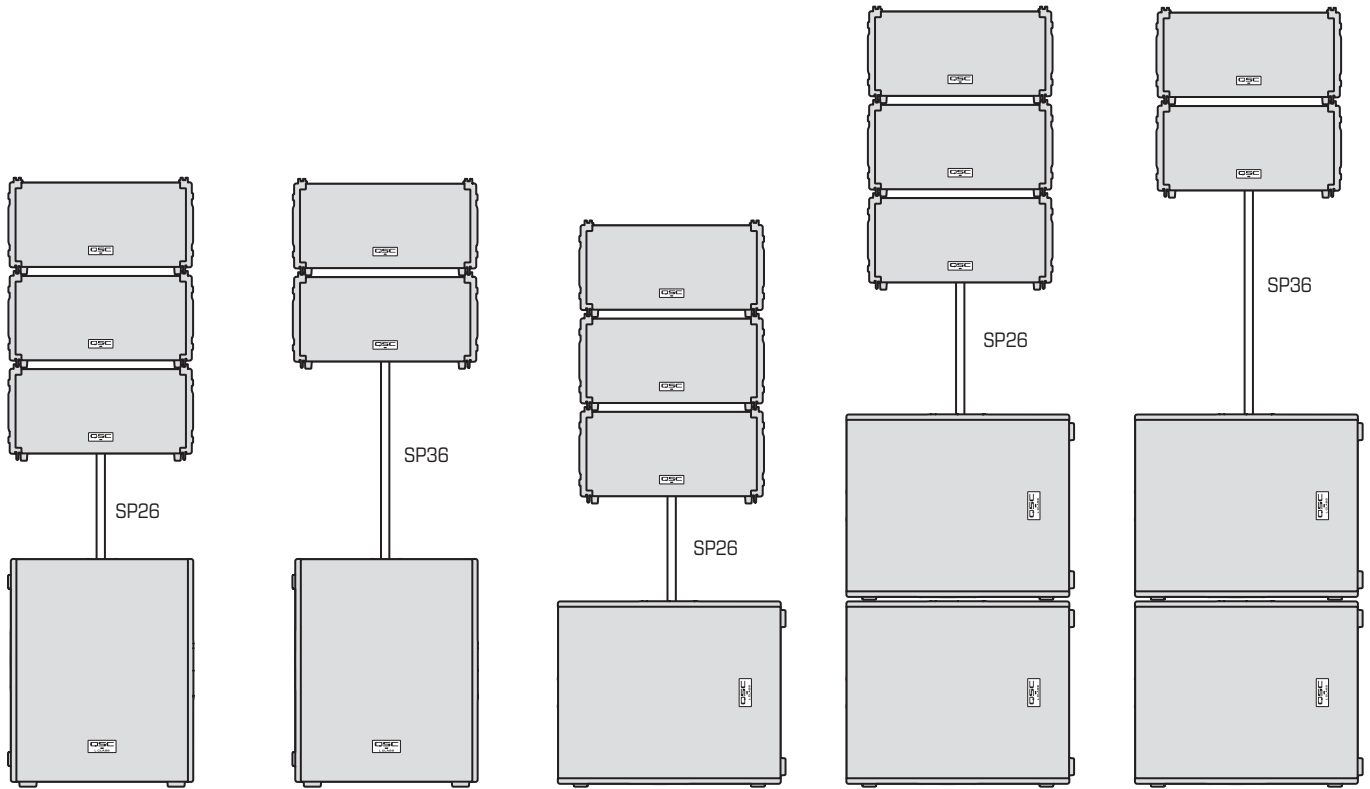

— Figure 16 —

**NOTE:** The above graphic illustrates the maximum safe deployment of each configuration given optimal environmental factors.

**WARNING!** Please take additional care to secure or stabilize your equipment in case of uneven ground, vibrating surfaces, winds, or any other scenario that could create a tipping hazard. (See — Figure 17 —)



— Figure 17 —

## LA112 Loudspeaker

Two (2) LA112 loudspeakers can be safely pole-mounted using a QSC threaded subwoofer pole over:

- a. one (1) LS118/KS118 subwoofer when the subwoofer is upright, or
- b. two (2) LS118/KS212C when the subwoofers are rotated on their side.

In the above configurations, the subwoofer pole should be no longer than 66 cm (26 inches). The QSC SP-26 accessory (sold separately) is suitable for this task.

If one (1) LA112 loudspeaker is pole-mounted using a QSC threaded subwoofer pole, then the subwoofer pole (QSC SP-36 accessory sold separately) length can be safely increased to 91 cm (36 inches) in the configurations shown below.



**WARNING!:** Longer pole lengths should not be used unless the subwoofer is securely attached to the ground with additional straps or hardware to prevent tipping hazard.

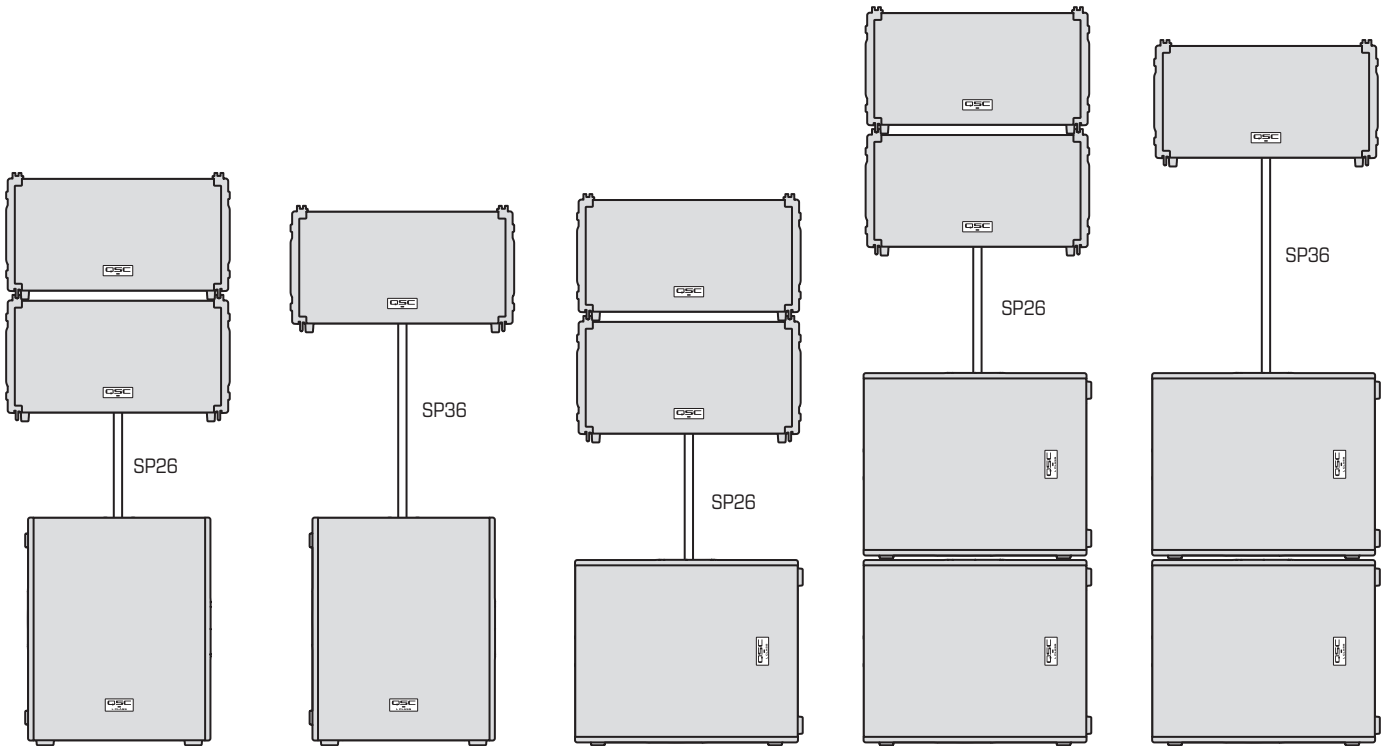

— Figure 18 —

**NOTE:** The above graphic illustrates the maximum safe deployment of each configuration given optimal environmental factors.

**WARNING!:** Please take additional care to secure or stabilize your equipment in case of uneven ground, vibrating surfaces, winds, or any other scenario that could create a tipping hazard. (See — Figure 19 —)



— Figure 19 —

## Pole Mounting a Loudspeaker over a Subwoofer(s)

To deploy a pole mount over a subwoofer(s) with a tilt of 0° or -7.5°, mount the loudspeaker using the 35 mm pole socket labeled 0° or -7.5° on the bottom of the loudspeaker.

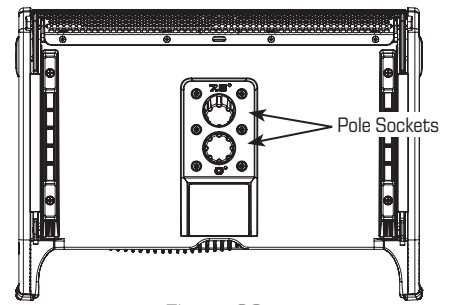

— Figure 20 —

## Stacking an Array on a Pole Mount over a Subwoofer(s)

1. After securing the first loudspeaker to the pole, set the Locking Levers on both sides of the new loudspeaker to the middle (ADD+) position.
2. Hook both Front Strikes of the new loudspeaker onto the Front Hooks of the loudspeaker mounted to the pole.
3. Lower the back side of the loudspeaker until the new loudspeaker connects with the loudspeaker mounted to the pole, making a click sound.
4. Push Locking Levers down (LOCK) to secure the new loudspeaker on both sides.
5. Repeat steps 1-4, until array is complete.

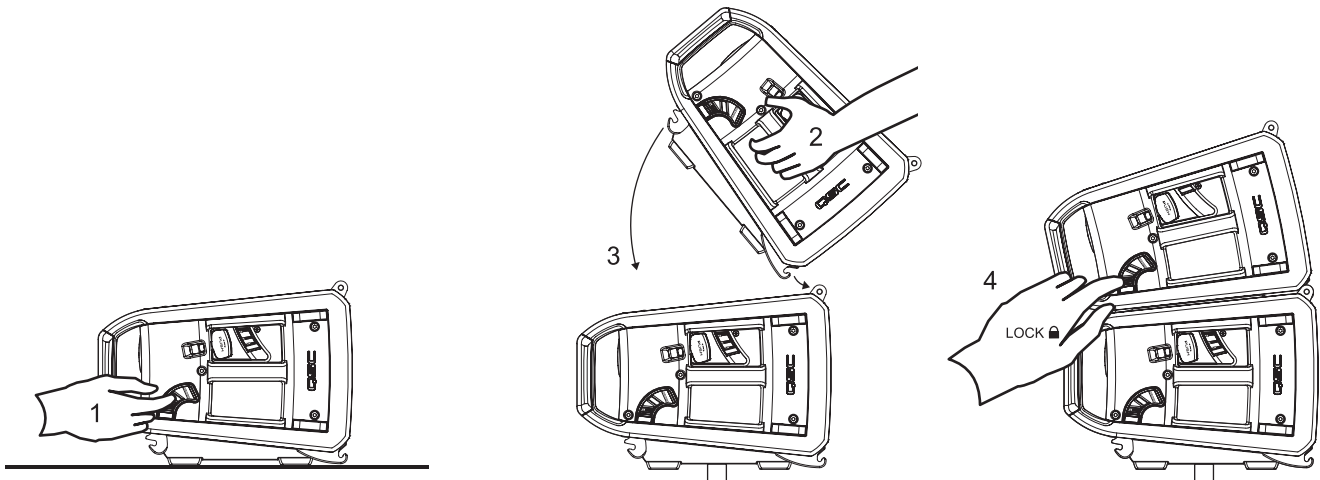

— Figure 21 —

## Splay Angle Adjustment on a Pole Mount over a Subwoofer(s)

Along with the 0° and -7.5° angle options on a pole mount, splay angle of individual loudspeakers can be adjusted further to 1.5°, 6°, and 12°.

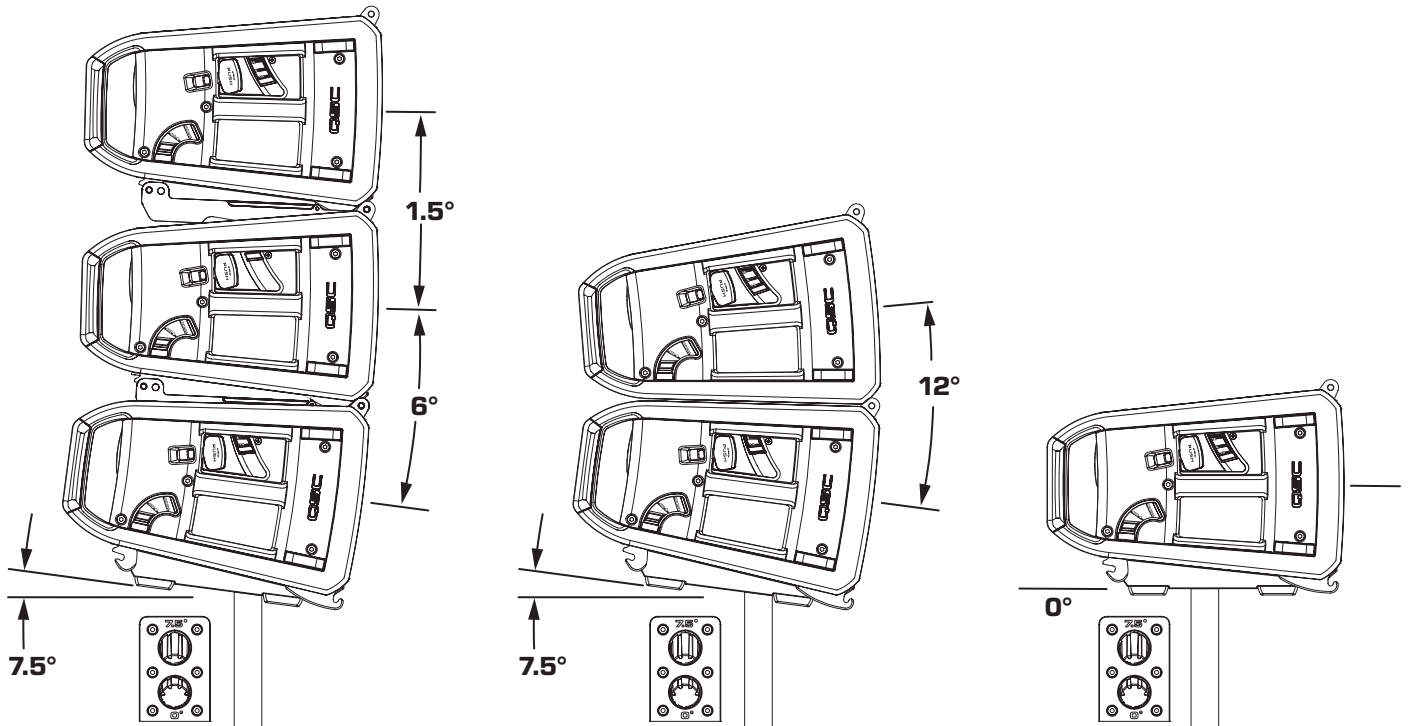

— Figure 22 —

**NOTE:** See the section on “Understanding Splay Angles” for further details.

### Decreasing Angle

1. Push Angle Lever on both sides all the way in, until they make a click sound and stay depressed.
2. Lift loudspeaker up into the next angle position, until it makes a click sound.

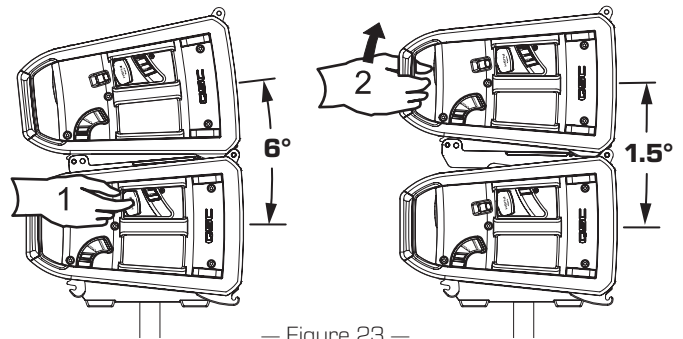

— Figure 23 —

### Increasing Angle

1. Push Angle Lever on both sides all the way in, until they make a click sound and stay depressed.
2. Slightly lift loudspeaker weight to release internal pin.
3. Lower loudspeaker into the next angle position, until it makes a click sound.

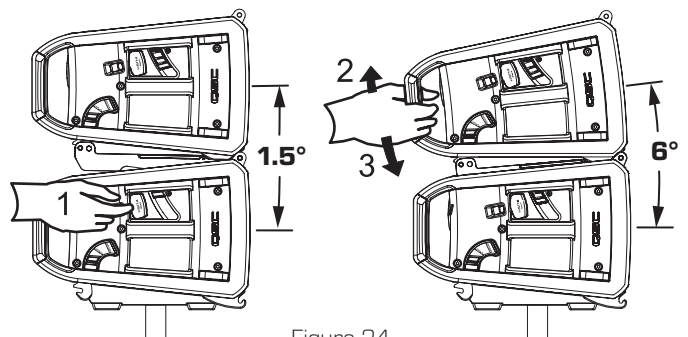

— Figure 24 —

## Stacking over a Subwoofer(s)

LA108/LA112 active line array loudspeakers offer the ability to safely stack an array over an LS118/KS118 subwoofer(s) unit using the appropriate Array Frame and Sub Stack Adapter Kit (not included, sold separately).



**WARNING!** When deploying loudspeakers on subwoofers, additional attention should be given to account for environmental conditions such as level surfaces, vibrations, wind, etc. to deploy the loudspeakers in a stable and safe manner. Use additional measures to secure the subwoofer (not included) when necessary.

### LA108 Loudspeaker

An array of up to four (4) LA108 loudspeakers can be stacked over:

- One (1) LS118/KS118 subwoofer when the subwoofer is upright, or
- Two (2) LS118/KS212C subwoofers when rotated on their side.

**NOTE:** For this ground-stack deployment, the LA108-AF (Array Frame) and the LA108-KIT-SA (Stack Adapter Kit) accessories are needed (not included, sold separately). These combined accessories bolt onto the M20 thread on top of the subwoofer to secure the array. For more details concerning the assembly of these two accessories, please refer to the individual accessories' user manuals.

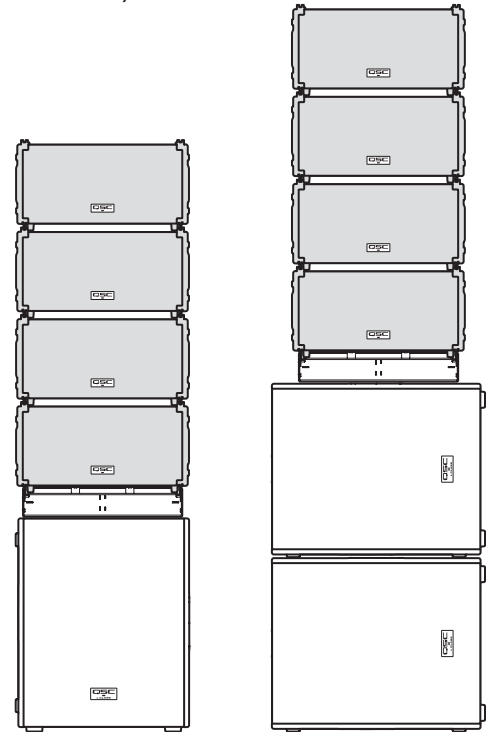

— Figure 25 —

### LA112 Loudspeaker

An array of up to three (3) LA112 loudspeakers can be stacked over one (1) or two (2) LS118/KS212C when the subwoofers are rotated on their side.

**NOTE:** For this ground-stack deployment, the LA112-AF (Array Frame) and the LA112-KIT-SA (Stack Adapter Kit) accessories are needed (not included, sold separately). These combined accessories bolt onto the M20 thread on top of the subwoofer to secure the array. For more details concerning the assembly of these two accessories, please refer to the individual accessories' user manuals.

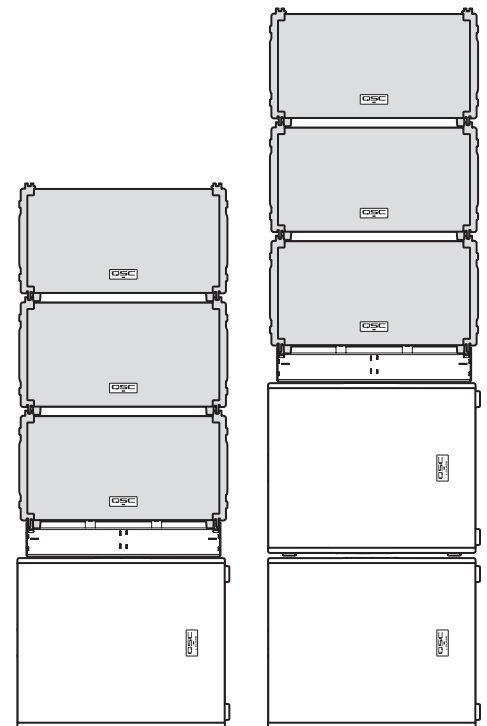

— Figure 26 —

## Attaching an Array Frame and Stack Adapter Kit to a Subwoofer

1. Carefully remove paper backing from the adhesive sides of the Bumper Pads. Adhere Bumper Pads to the bottom of the Array Frame as shown.
2. Secure the Tie-Down Assembly to the M20 thread located on top, or side, of the subwoofer enclosure. Tighten screw with fingers until snug. If necessary, tighten further using a coin, a key, or a large screwdriver.
3. Place Array Frame on subwoofer with the Bumper Pads facing downward.
4. Use the Tie-Down Knob to secure the Array Frame to the Tie-Down Assembly. Tie-Down Knob is now secured to the subwoofer.

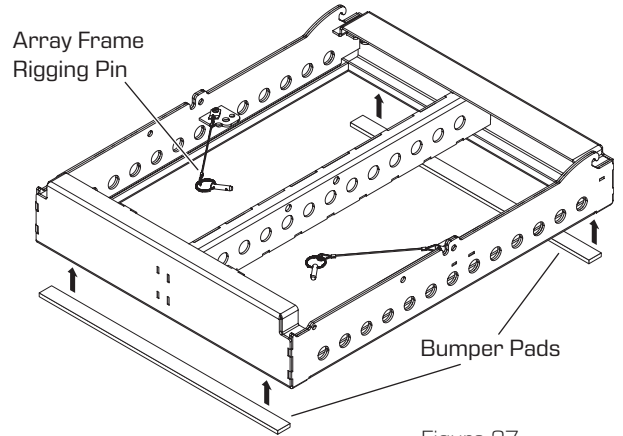

— Figure 27 —

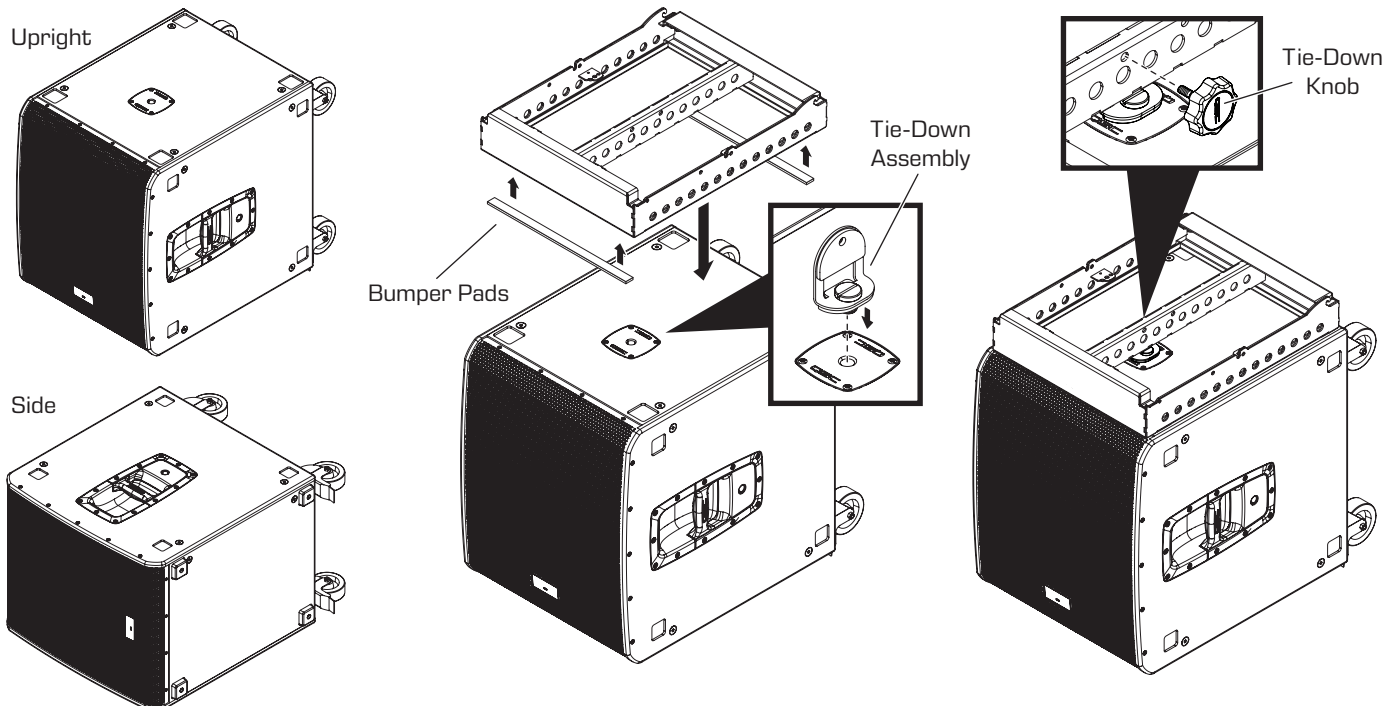

— Figure 28 —



5. Attach the front end of each Angle Arm (part of the Stack Adapter Kit, sold separately) to each side of the Array Frame. Secure each side with the Angle Arm Rigging Pins.
6. Adjust the Angle Arms to the desired angle. Secure each with the Array Frame Rigging Pins.

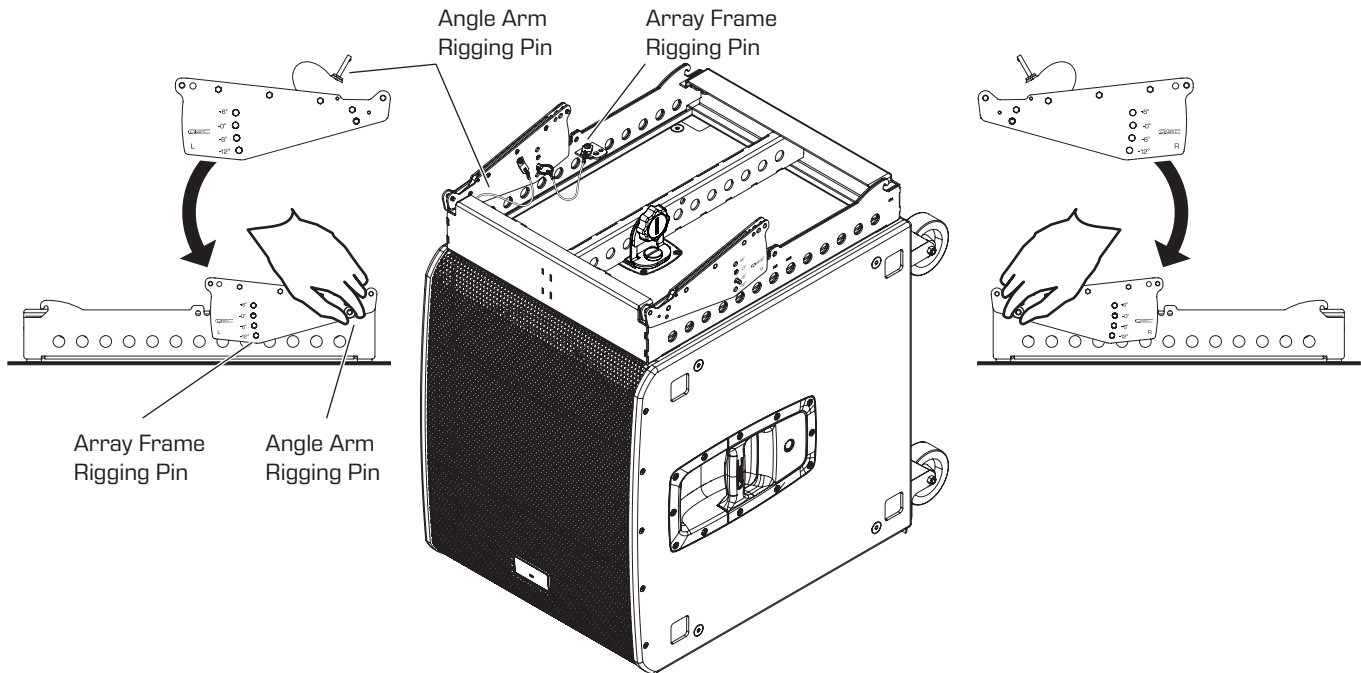

— Figure 29 —

### Attaching a Loudspeaker to a Subwoofer

1. After securing the Array Frame and Stack Adapter Kit to the subwoofer, set the Locking Levers on both sides of the loudspeaker to the middle (ADD+) position.
2. Hook both Front Strikes of the loudspeaker onto the Front Hooks of the Array Frame.
3. Lower the back side of the loudspeaker until the Angle Arm latches onto the Rear Hook of the loudspeaker on both sides, making a click sound.
4. Push Locking Levers down (LOCK) to secure loudspeaker on both sides.

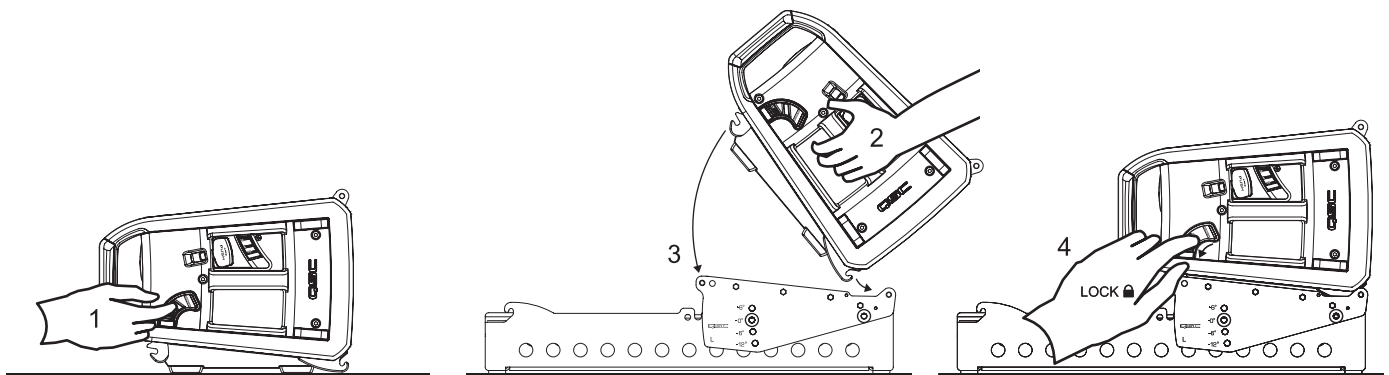

— Figure 30 —

## Detaching a Loudspeaker from a Subwoofer

1. Set the Locking Levers on both sides of the loudspeaker to the up (REMOVE) position.
2. Lift backside of the loudspeaker away from the Angle Arms.
3. Lift loudspeaker off Array Frame Front Hooks to fully detach.

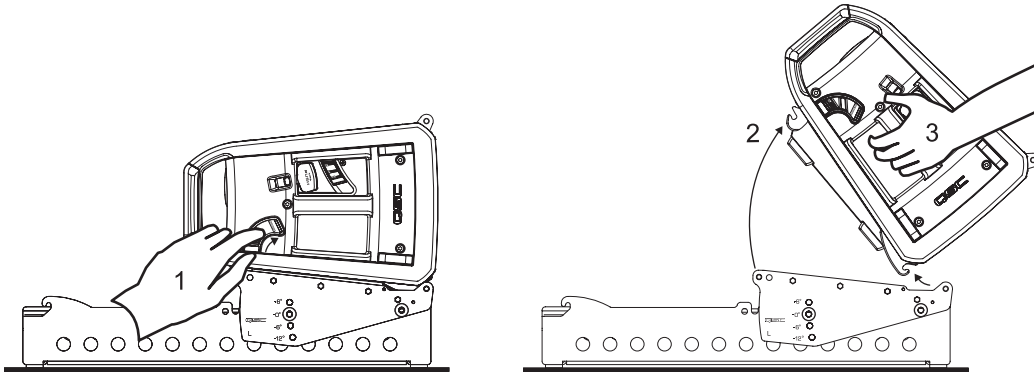

— Figure 31 —

## Stacking an Array of Loudspeakers on a Subwoofer

1. After securing the first loudspeaker to the Array Frame and stack adapter, set the Locking Levers on both sides of the new loudspeaker to the middle (ADD+) position.
2. Hook both Front Strikes of the new loudspeaker onto the Front Hooks of the loudspeaker mounted to the pole.
3. Lower the back side of the loudspeaker until the new loudspeaker connects with the loudspeaker mounted to the pole, making a click sound.
4. Push Locking Levers down (LOCK) to secure the new loudspeaker on both sides.
5. Repeat steps 1-4, until array is complete.

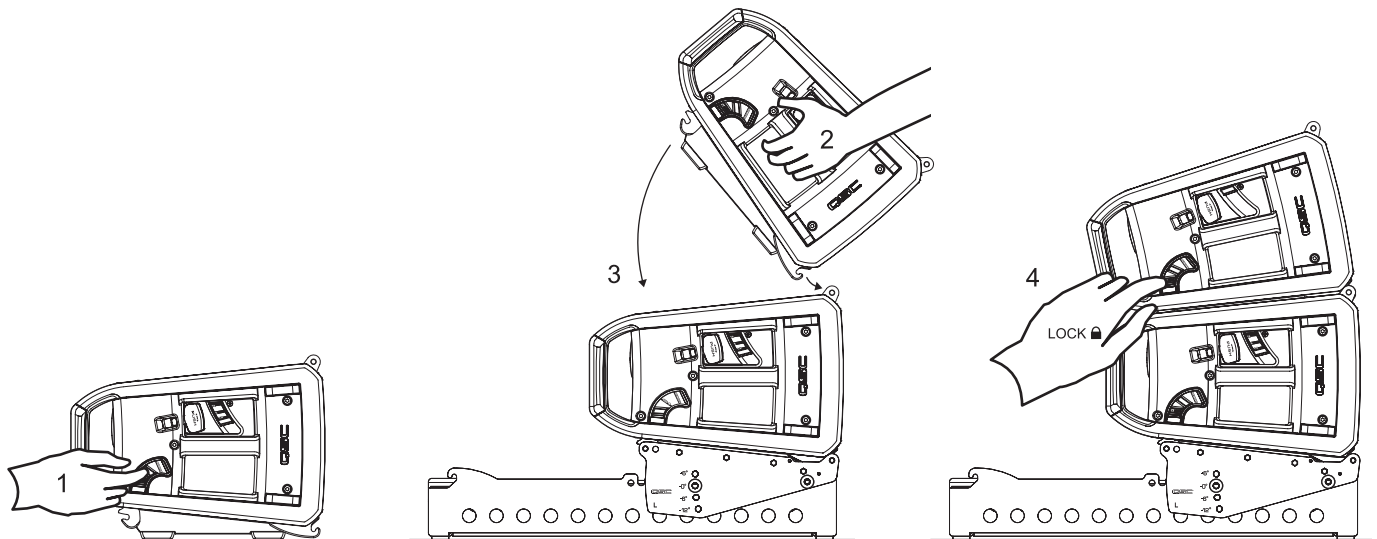

— Figure 32 —



**WARNING!** Make sure the loudspeakers are physically, properly aligned; if not, the latching system may not properly engage, and the loudspeakers could separate causing physical damage, and/or personal injury.

## Splay Angle Adjustment for a Subwoofer Stack

The Stack Adapter allows loudspeakers to be installed at 6°, 0°, -6°, and -12°.

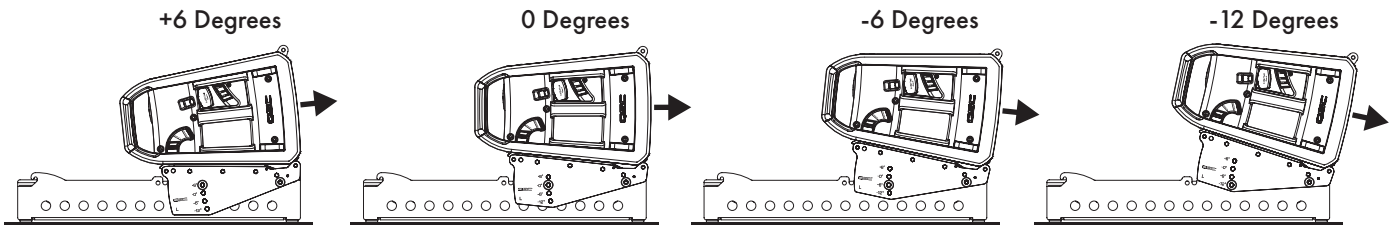

— Figure 33 —

**NOTE:** See the section on “Understanding Splay Angles” for further details.

## Decreasing Angle

1. Push Angle Lever on both sides all the way in, until they make a click sound and stay depressed.
2. Lift loudspeaker up into the next angle position, until it makes a click sound.

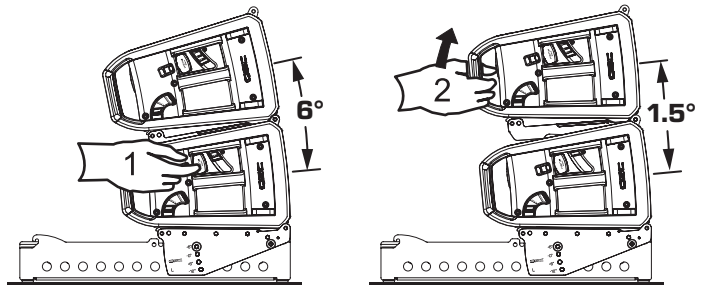

— Figure 34 —

## Increasing Angle

1. Push Angle Lever on both sides all the way in, until they make a click sound and stay depressed.
2. Slightly lift loudspeaker weight to release internal pin.
3. Lower loudspeaker into the next angle position, until it makes a click sound.

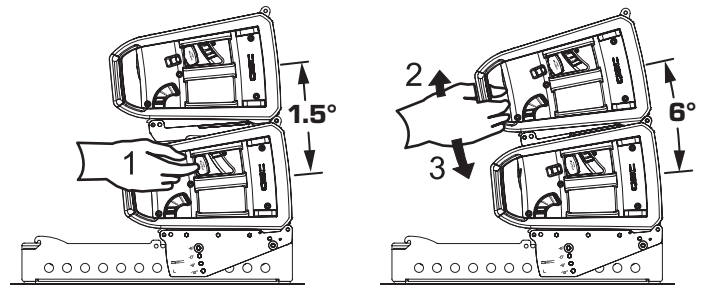

— Figure 35 —

## Front Fill (Stage-Lip)

When used as a stand-alone loudspeaker, the integrated lower feet of the LA108/LA112 active line array loudspeakers ensure that the enclosure remains exactly perpendicular to the stage floor, making it ideal for front-fill or stage-lip deployments.

Additionally, the daisy-chain capabilities of the LA108/LA112 (analog and digital signals, as well as AC power) ensure a clean installation setup with minimal cable runs.

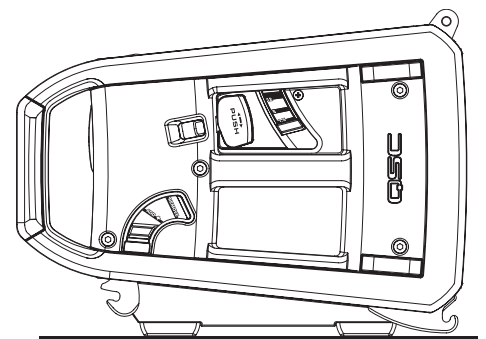

— Figure 36 —

# Ground Stack

Stand-alone loudspeakers can also be stacked when used with the Array Frame and Stack Adapter Kits (not included, sold separately).

## Preparing an Array Frame and Stack Adapter Kit for a Ground Stack

1. Adhere the adhesive sides of the Bumper Pads to the bottom of the Array Frame as shown.
2. Secure the Array Frame to the surface where the ground stack is to be deployed, using fasteners or other suitable hardware (not included) for the location of deployment.



**WARNING!:** The Array Frame **MUST** be secured to the surface where the ground stack is deployed to prevent unintended tipping.

**NOTE:** Before deploying the complete ground stack, make sure the Array Frame is adequately placed on a flat, solid surface. Make sure the ground stack cannot slip or slide due to sound vibrations or other disturbances, such as people pushing/pulling the stack.

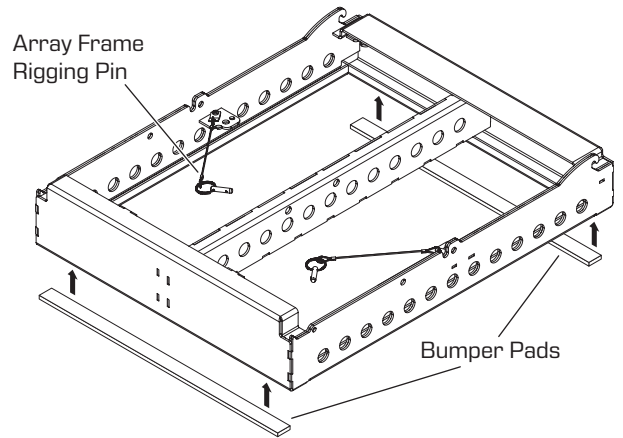

— Figure 37 —

3. Attach the front end of each Angle Arm (part of the Stack Adapter Kit, sold separately) to each side of the Array Frame. Secure each side with the Angle Arm Rigging Pins.
4. Adjust the Angle Arms to the desired angle. Secure each with the Array Frame Rigging Pins.

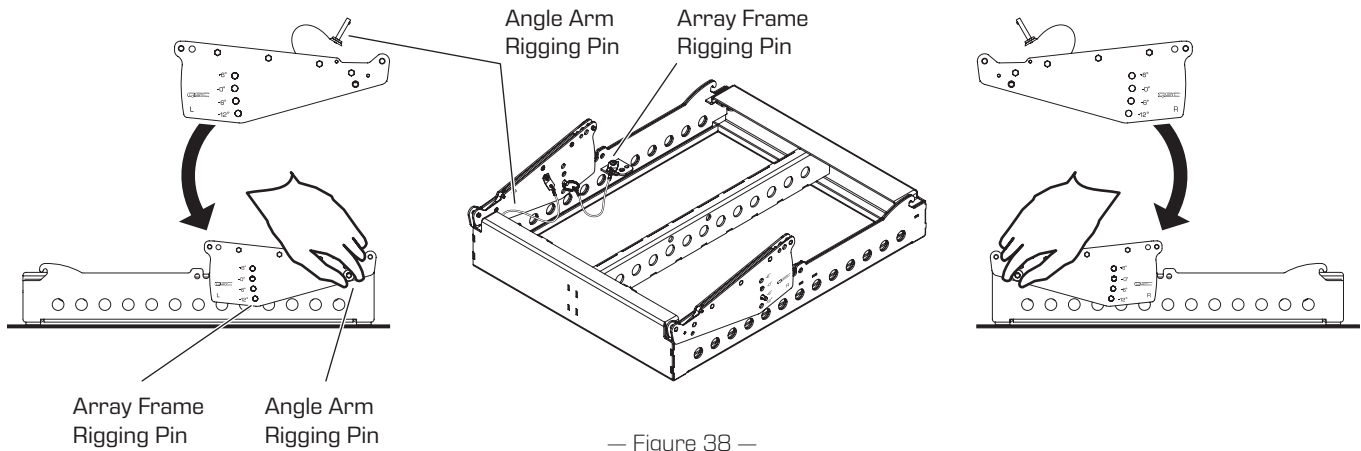

— Figure 38 —

## Attaching a Loudspeaker to an Array Frame for a Ground Stack

1. After securing the Array Frame and Stack Adapter Kit to the surface where the stack will be deployed, set the Locking Levers on both sides of the loudspeaker to the middle (ADD+) position.
2. Hook both Front Strikes of the loudspeaker onto the Front Hooks of the Array Frame.
3. Lower the back side of the loudspeaker until the Angle Arm latches onto the Rear Hook of the loudspeaker on both sides, making a click sound.
4. Push Locking Levers down (LOCK) to secure loudspeaker on both sides.

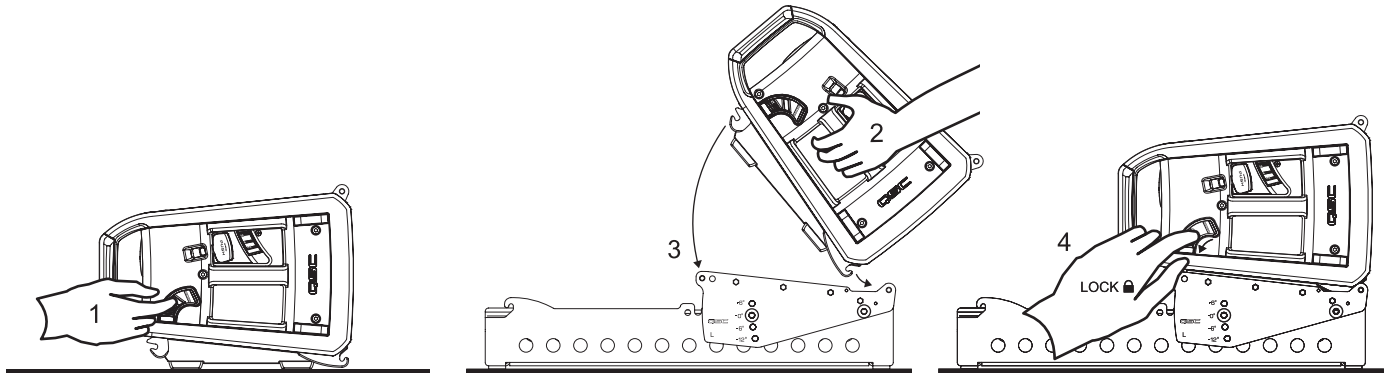

— Figure 39 —

## Detaching a Loudspeaker from an Array Frame for a Ground Stack

1. Set the Locking Levers on both sides of the loudspeaker to the up (REMOVE) position.
2. Lift backside of the loudspeaker away from the Angle Arms.
3. Lift loudspeaker off Array Frame Front Hooks to fully detach.

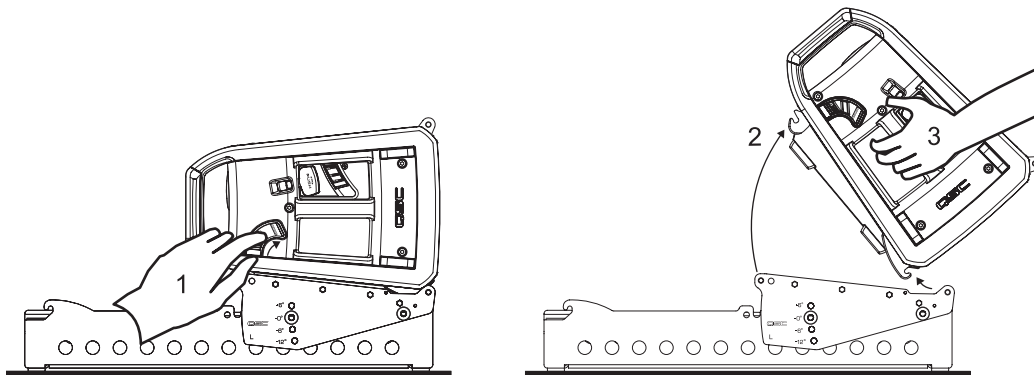

— Figure 40 —

## Stacking an Array of Loudspeakers for a Ground Stack

1. After securing the first loudspeaker to the Array Frame and stack adapter, set the Locking Levers on both sides of the new loudspeaker to the middle (ADD+) position.
2. Hook both Front Strikes of the new loudspeaker onto the Front Hooks of the loudspeaker mounted to the pole.
3. Lower the back side of the loudspeaker until the new loudspeaker connects with the loudspeaker mounted to the pole, making a click sound.
4. Push Locking Levers down (LOCK) to secure the new loudspeaker on both sides.
5. Repeat steps 1-4, until array is complete.

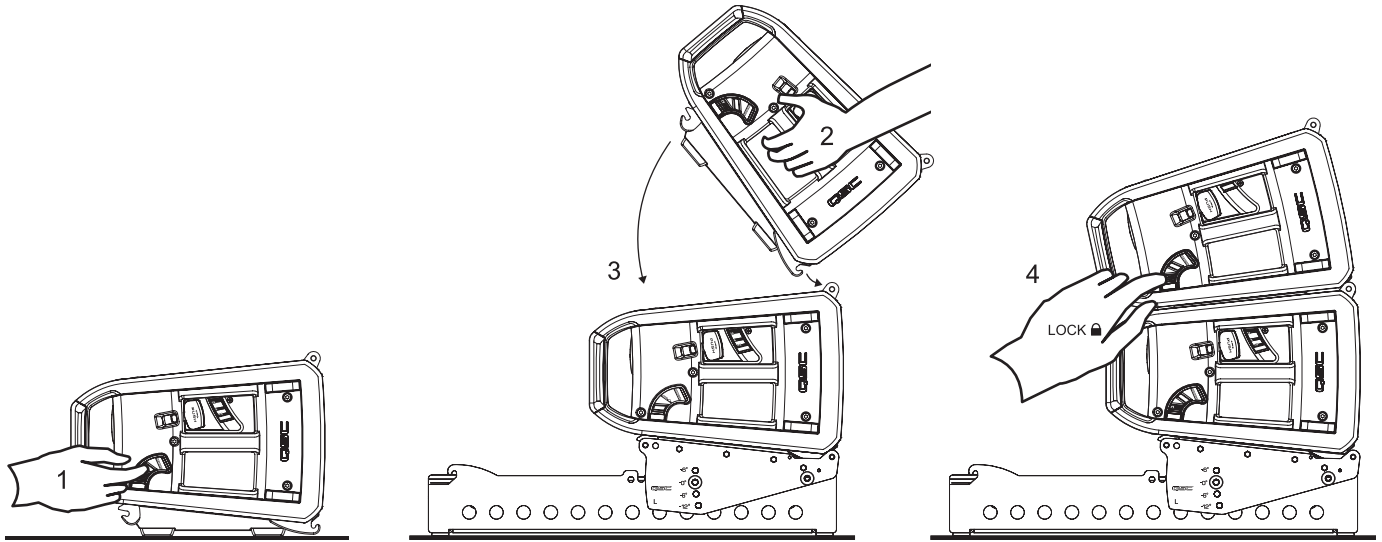

— Figure 41 —



**WARNING!:** Make sure the loudspeakers are physically, properly aligned; if not, the latching system may not properly engage, and the loudspeakers could separate causing physical damage, and/or personal injury.

## Splay Angle Adjustment for Ground Stack

The Stack Adapter allows loudspeakers to be installed at 6°, 0°, -6°, and -12°.

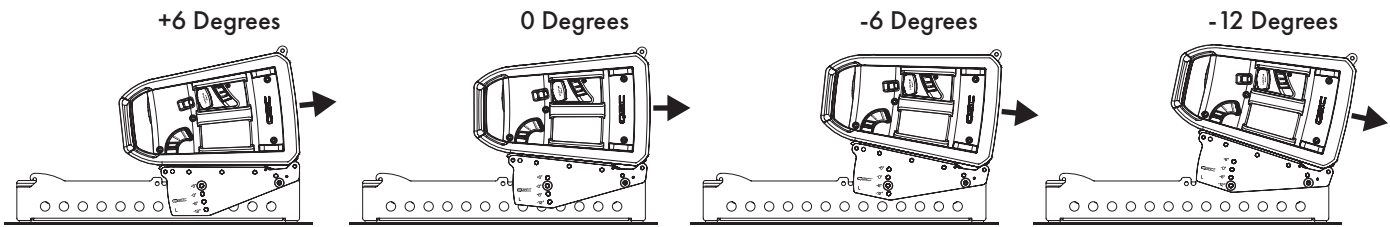

— Figure 42 —

**NOTE:** See the section on “Understanding Splay Angles” for further details.

## Decreasing Angle

1. Push Angle Lever on both sides all the way in, until they make a click sound and stay depressed.
2. Lift loudspeaker up into the next angle position, until it makes a click sound.

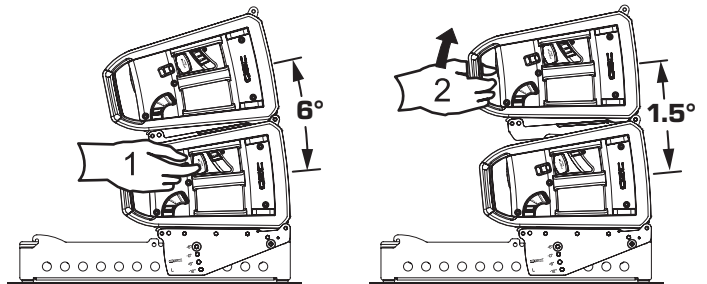

— Figure 43 —

## Increasing Angle

1. Push Angle Lever on both sides all the way in, until they make a click sound and stay depressed.
2. Slightly lift loudspeaker weight to release internal pin.
3. Lower loudspeaker into the next angle position, until it makes a click sound.

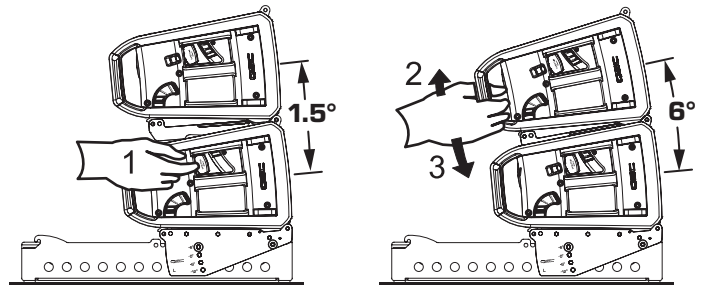

— Figure 44 —

## Horizontal Array

There may be situations where very narrow horizontal coverage is required to avoid spillover, such as a stage side-fill or drum monitor. In this application, the LA108/LA112 enclosures can be safely rotated onto their side to create tightly-packed horizontal arrays, which can be seated on a solid base (typically a road-case or a subwoofer).

Rubber feet on either side of the enclosure have been included to prevent side panels from damage.

**NOTE:** When rotating a LA108 or LA112 onto its side, there is only one correct orientation – with the high frequency waveguide towards the top. An arrow on the rear panel indicates which side of the enclosure the high frequency waveguide is located.

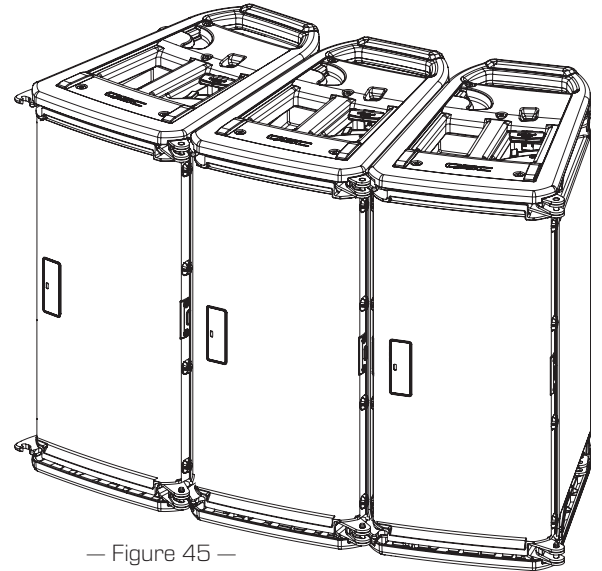

— Figure 45 —

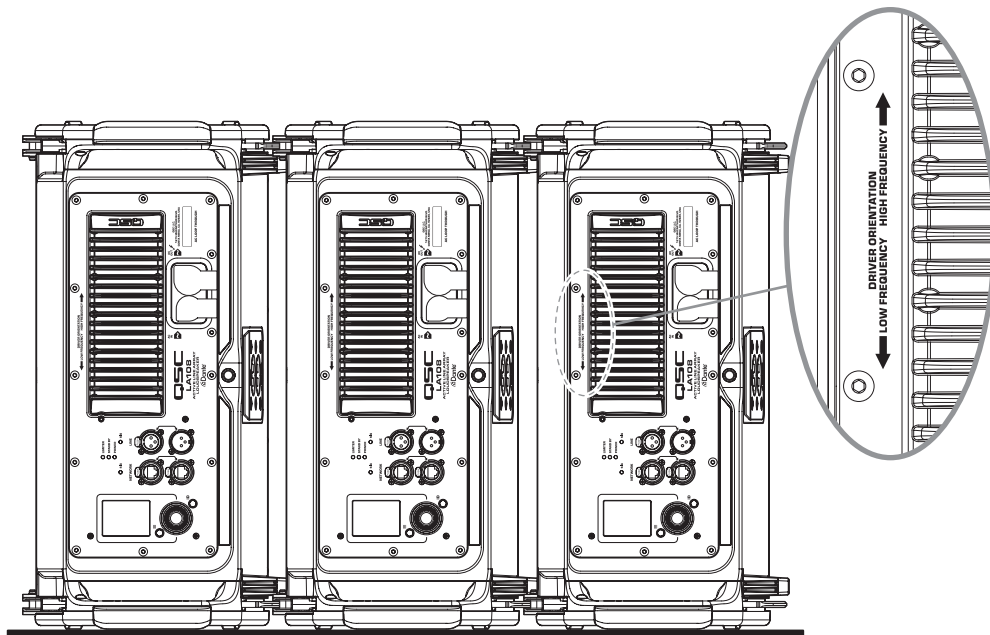

— Figure 46 —

## Stacked Horizontal Array

In a stacked horizontal array, it is possible to employ the upward-facing rigging mechanism to secure the boxes together.

1. Connect the array boxes together normally in the vertical ground stack configuration. (See Ground Stack directions above for further details)
2. Identify which side of the loudspeaker has the low frequency wave guide, using the arrow guide on the rear panel.



— Figure 48 —

3. Unlock the hardware on the low frequency-side of each loudspeaker in the array.
4. Press the Angle Lever to collapse the Angle Bar to 12° (fully collapsed) only on the low frequency side of each loudspeaker in the array.
5. Ensure hardware is connected and locked on the high frequency-side of each loudspeaker in the array.
6. Carefully rotate the entire array onto its low frequency side. The horizontal array is ready for use.

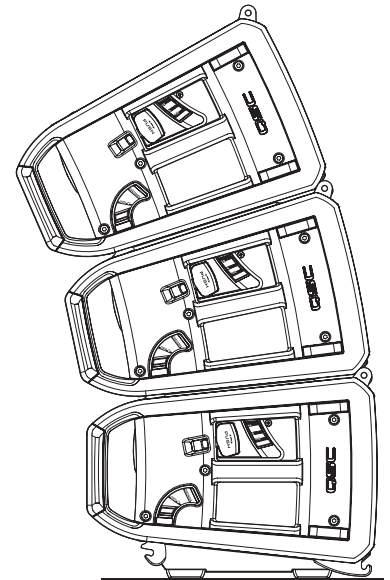

— Figure 47 —

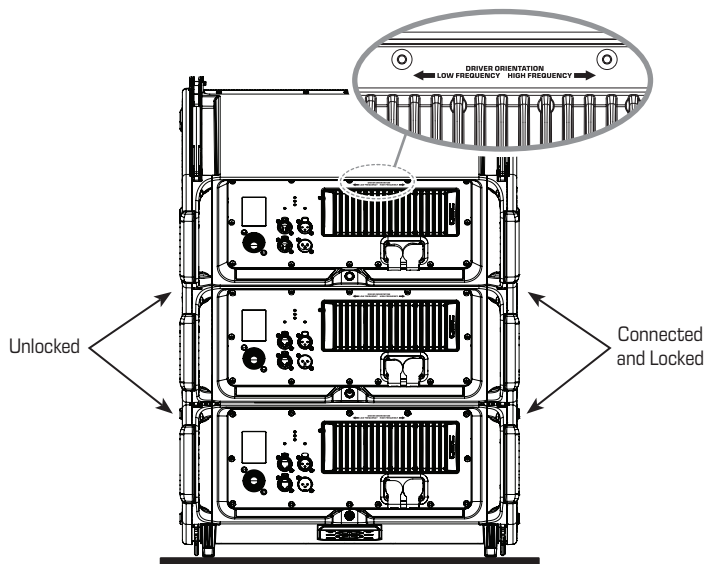

— Figure 49 —

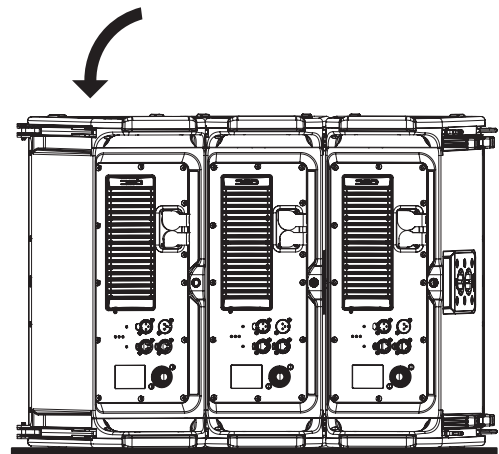

— Figure 50 —



## Splay Angle Adjustment for Stacked Horizontal Array

1. Push Angle Levers on the high frequency side of the loudspeakers all the way in, until they make a click sound and stay depressed.
2. Array can be extended or contracted, depending on coverage needs.

Number of Boxes	Splay Angles	Horizontal Coverage
1	n/a	15 degrees
2	12	27 degrees
3	12/12	39 degrees
4	12/12/12	51 degrees

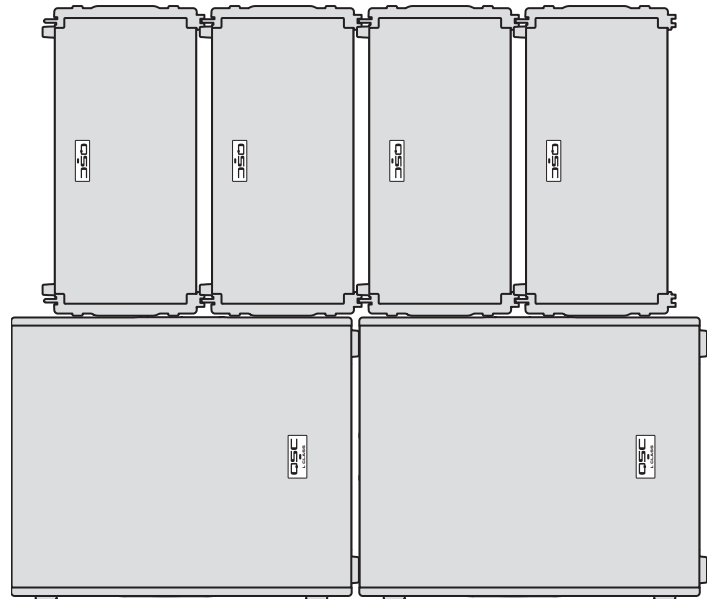

— Figure 51 —

## Detaching Loudspeakers from a Stacked Horizontal Array

1. Disengage the rigging mechanisms on the high frequency side of each loudspeaker in the array.
2. Remove loudspeakers one at a time to ensure that no potential damage to the rigging occurs.

# Flown Deployment

**NOTE:** Acceptable configurations of a flown array: 1) The position of the “Angle Bar” for any loudspeaker must be equal to or greater than the loudspeaker above it. 2) The sum of boom angles for all loudspeakers in an array, and overall array tilt, must be less than or equal to 84 degrees.

## Flown Deployment with an Array Frame

**NOTE:** Bumper Pads must be adhered to the bottom of the Array Frame for stacking. See the sections for Ground Stacking and Stacking over a Subwoofer(s) for more details.

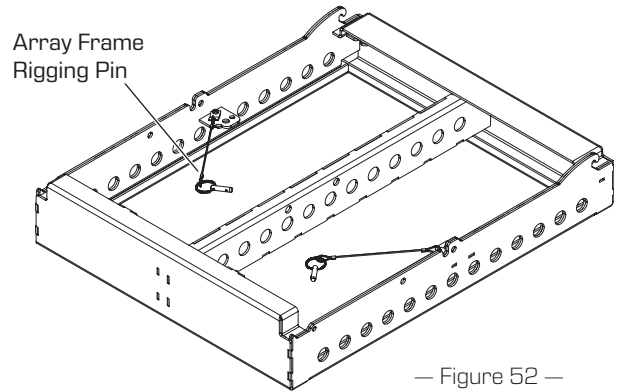

— Figure 52 —

## Array Frame Attachment Preparation

1. Push Angle Levers on both sides all the way in, until they make a click sound and stay depressed.
2. Push Angle Bar Lift up on both sides, until they make a click sound and the Angle Bar is at the 6° setting.
3. Repeat steps 1 and 2 to raise Angle Bar to the 1.5° setting.

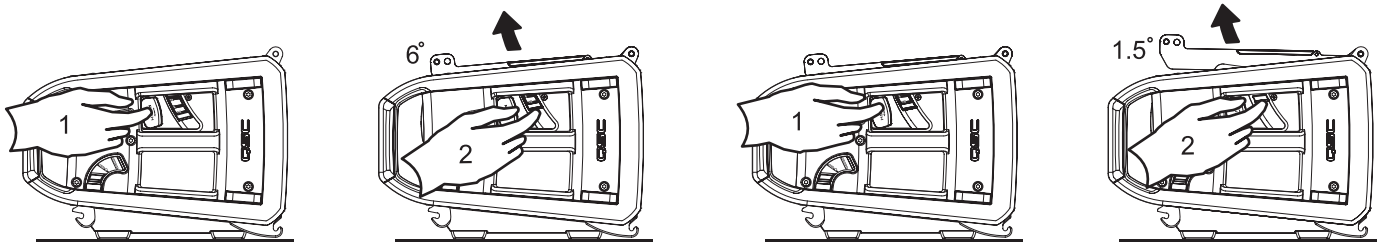

— Figure 53 —



**CAUTION!** When transporting the loudspeakers, return the Angle Bar to the retracted position (12° setting) and push the Lock Lever down to protect the QSC RapidDeploy latching mechanism.

## Attaching a Loudspeaker to the Array Frame

1. Hang both Front Strikes of the loudspeaker onto the Front Hooks of the Array Frame.
2. Lift rear handles of the loudspeaker until the Angle Bar reaches the Array Frame. Secure the loudspeaker Angle Bars to the Array Frame with the Array Frame Rigging Pins on both sides.



**WARNING!** Both Rigging Pins must be used to safely secure the loudspeaker to the Array Frame. Never use only one pin!

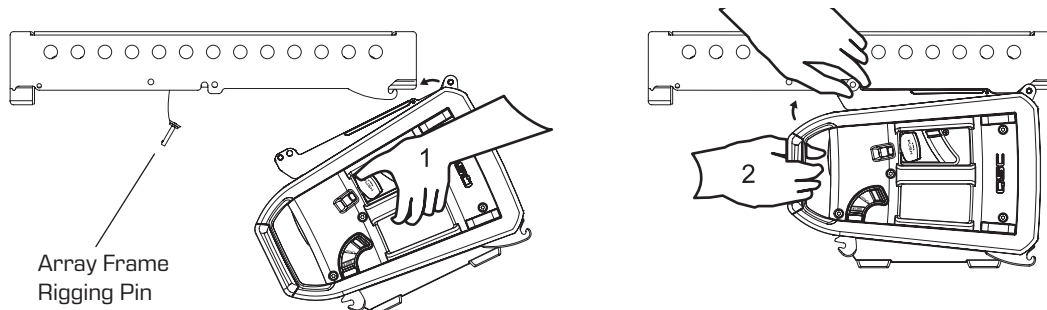

— Figure 54 —

## Attaching Loudspeakers for an Array

1. Set the Locking Levers on the upper loudspeaker to the middle (ADD+) position on both sides.
2. Hang both Front Strikes of the lower loudspeaker onto the Front Hooks of the upper loudspeaker.
3. Lift rear handles of the lower loudspeaker until the Angle Bar connects to the Rear Hooks of the upper loudspeaker on both sides, making a click sound.
4. Push the Locking Levers down (LOCK) on both sides of the upper loudspeaker.
5. Repeat steps 1-4, until array is complete.



**IMPORTANT:** When rigging loudspeakers together or to the Array Frame, attach the bottom unit to the one above using the QSC RapidDeploy latching mechanism on the upper unit.

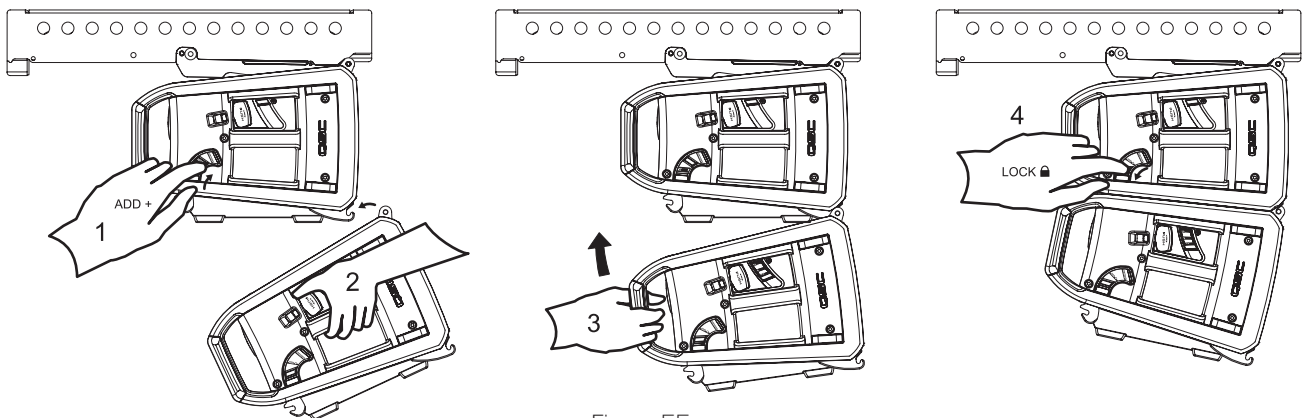

— Figure 55 —



**WARNING!:** Make sure the loudspeakers are physically, properly aligned; if not, the latching system may not properly engage, and the loudspeakers could separate causing physical damage, and/or personal injury.

## Detaching Loudspeakers from an Array

1. Support the weight of the lower loudspeaker and push the Locking Levers up (REMOVE) on both sides of the upper loudspeaker.
2. Lower the loudspeaker carefully using the rear handles. The loudspeaker remains suspended on the Front Strikes of the upper loudspeaker.
3. Lift the lower loudspeaker off the Front Hooks of the upper loudspeaker to fully detach.
4. Push the Locking Lever down (LOCK) on the upper loudspeaker.

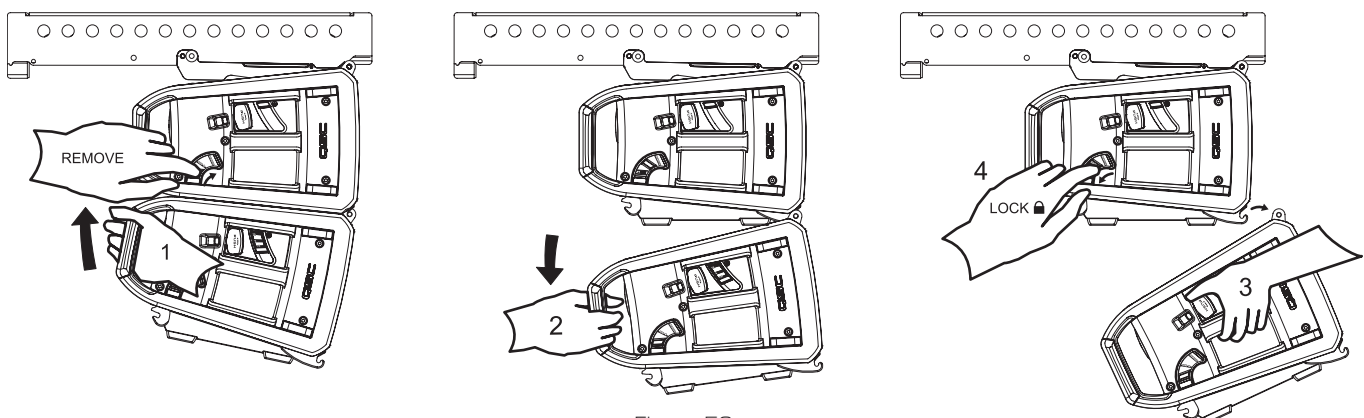

— Figure 56 —

## Detaching a Loudspeaker from the Array Frame

1. Support the weight of the loudspeaker. Remove the Array Frame Rigging Pins on both sides.
2. Lower loudspeaker carefully using rear handles. Loudspeaker remains suspended on Front Strikes.
3. Lift loudspeaker off Array Frame Front Hooks to fully detach.

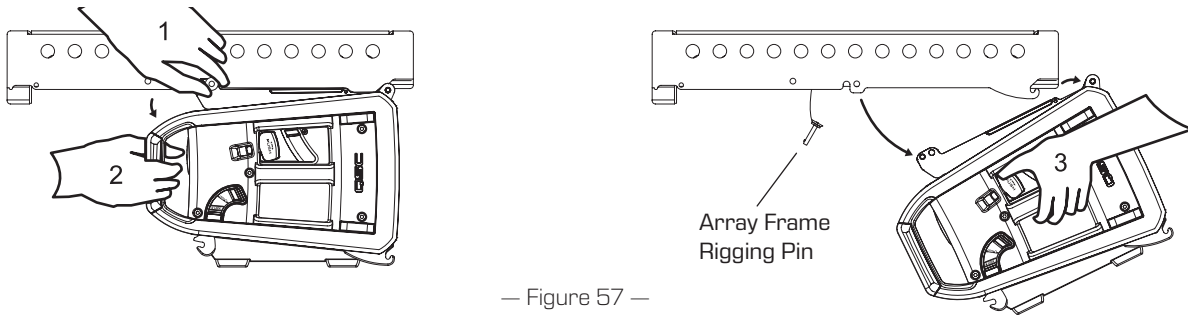

— Figure 57 —

## Splay Angle Adjustment for Flown Deployment

The splay angles for loudspeakers within an array can be adjusted individually to 1.5°, 6°, and 12°.

**NOTE:** See the “Understanding Splay Angles” section for further details.

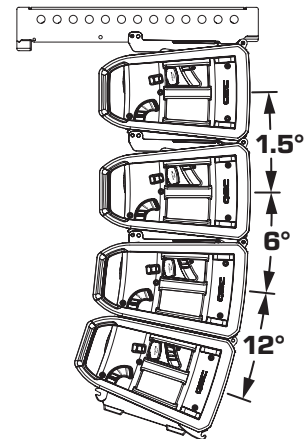

— Figure 58 —

### Decreasing Angle

1. Push Angle Lever on both sides all the way in, until they make a click sound and stay depressed.
2. Lift loudspeaker weight slightly to release internal pin.
3. Lower loudspeaker down to the next angle position, until it makes a click sound.

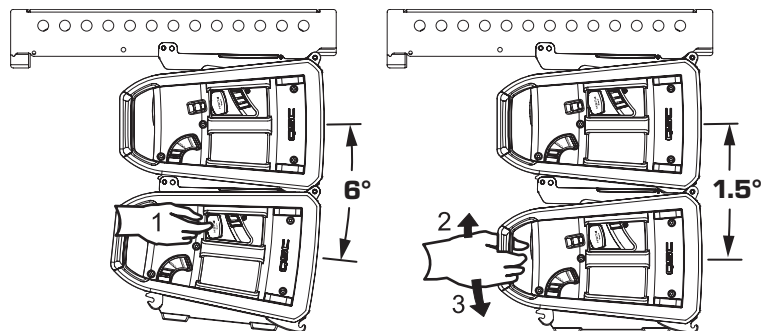

— Figure 59 —

### Increasing Angle

1. Push Angle Lever on both sides all the way in, until they make a click sound and stay depressed.
2. Lift loudspeaker up into the next angle position, until it makes a click sound.

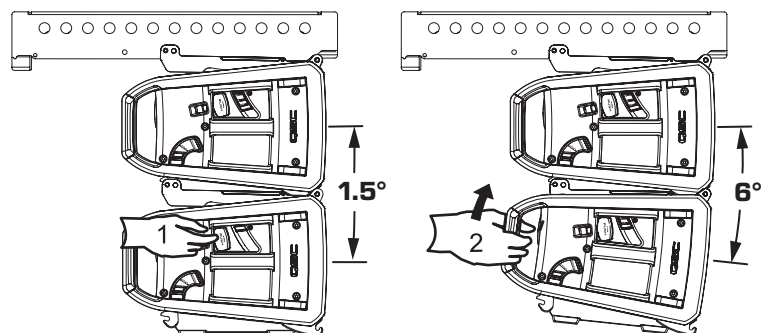

— Figure 60 —



**WARNING!** Always verify that the Locking Lever is in the full downward position (red indicator will not be visible when locked), and the Angle Lever is in the outward position after the hardware is connected. If not properly latched, the loudspeakers could separate or change angle unexpectedly and cause physical damage to the loudspeakers, and/or personal injury.

# Pick-Point Deployment

## Single Pick-Point Deployment

For single pick-point deployments, a 16 mm (5/8 in) shackle (not included) can be attached to the center rail of the Array Frame at the center-of-gravity (CG) point for the desired angle.

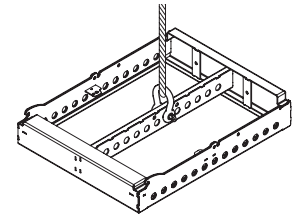

— Figure 61 —

## Dual Pick-Point Deployment

For a dual pick-point deployment with two pick-points, two 16 mm (5/8 inches) shackles (not included) can be attached to the center rail of the Array Frame at the CG point for the desired angle.

**NOTE:** Use EASE Focus 3 (available online) to locate the CG point and desired vertical angle for specific deployments.

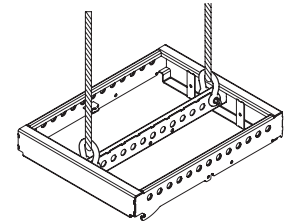

— Figure 62 —

## Bridle Deployment

For a bridle deployment with two pick-points, two 16 mm (5/8 in) shackles (not included) can be attached to the two outer rails of the Array Frame at the CG point for the desired angle.

**NOTE:** Use EASE Focus 3 (available online) to locate the CG point and desired vertical angle for specific deployments.

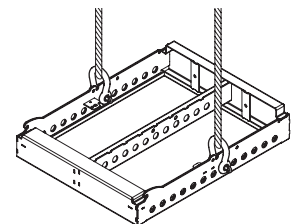

— Figure 63 —

## Adjusting the Tilt Angle of the Array on a Pick-Point Deployment

The tilt angle of the array can be adjusted for single pick-point and bridle deployments by moving the shackle(s) forward or backward on the Array Frame.

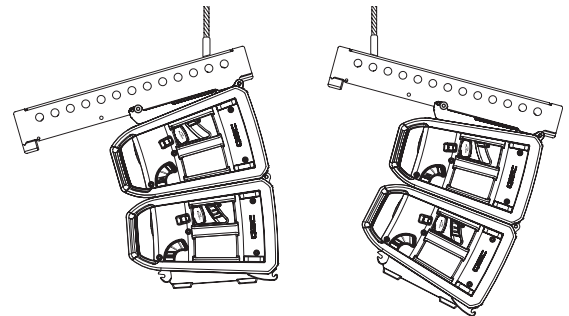

— Figure 64 —

## Optional Eyebolt

When a downtilt outside of the CG of the Array Frame is needed, an M10 Eyebolt can be used on the rear of the lowest loudspeaker of the array to provide another pick-point for further support to angle the system.

**WARNING!:** Do not exceed the Working Load Limits of the M10 Pullback Point as stated in "Maximum Suspended Load" on page 7.

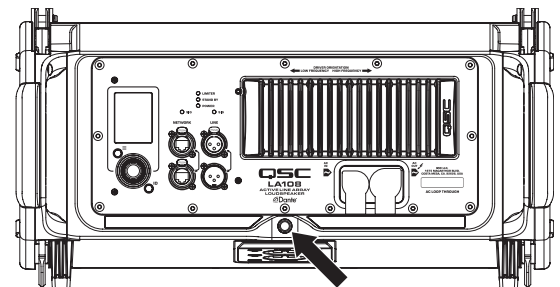

— Figure 65 —

# Rear Panel Connections

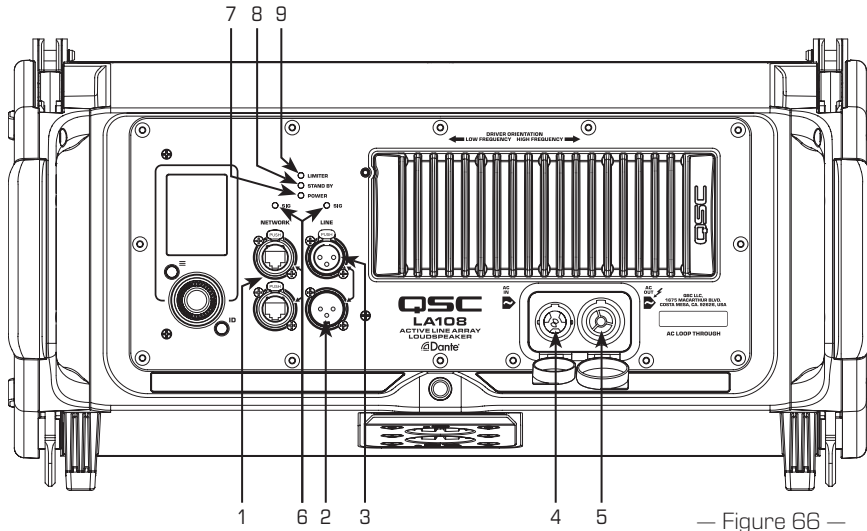

— Figure 66 —

1. Dual-switch EtherCON connections to QSC SysNav™ and/or Dante®-enabled system
2. Parallel (Thru) balanced analog output connection of the balanced input
3. Balanced analog input connection for line level sources
4. PowerCON TRUE1 locking AC Power INLET
5. PowerCON TRUE1 locking AC Power OUTLET
6. Indicates that signal is present on the associated input
7. Indicates that the loudspeaker is powered on
8. Indicates Standby Mode
9. Indicates that the loudspeaker DSP is limiting

## System Power

The LA108 and LA112 loudspeakers' electronic modules do not include a power switch. This is to prevent suspending an array with a loudspeaker's power switch inadvertently bumped off, or left in the off position. To power a loudspeaker on/off, either switch the AC supply at the plug source, or twist the AC POWER-IN connector clockwise or counter-clockwise to power each loudspeaker on/off (if AC power is connected).

For safety reasons, it is important to follow the proper power cable connection/disconnection sequence to power on or off loudspeakers.

Proper power on/off sequencing can help to prevent undesirable sounds from being introduced into the loudspeaker system (pops, clicks, thumps). Always follow the rule that loudspeakers are "last on, first off."



**WARNING!** The LA108 and LA112 loudspeakers employ a universal power supply, capable of operating the system with input AC power voltages ranging from 100 – 240 VAC at 50 – 60 Hz. Make sure to only use the power cable that is appropriate for the deployment location.

## AC Mains Connections

The LA108 and LA112 loudspeakers feature dual powerCON TRUE1 AC connectors to support daisy-chaining multiple loudspeakers within an array or for ground-stacking deployments.

Neutrik powerCON TRUE1 AC connectors have become standard in the AV production industry and are often found on lighting systems and portable LED walls. The benefits of the powerCON TRUE1 connector are:

- 20 Amp current capacity
- Safe connection/disconnection under load
- POWER-IN and POWER-OUT locking connectors can couple to create extension cables without the need for a separate barrel connector
- IP65 rating for ingress protection (once coupled)

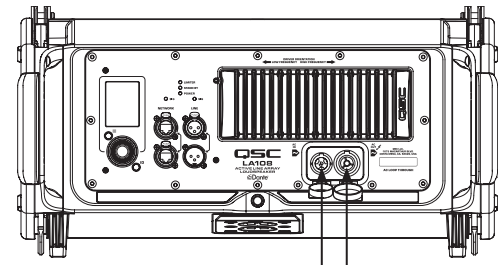

PowerCON TRUE1 AC connectors

— Figure 67 —

## Connecting to AC Mains

1. Insert the locking POWER-IN cable connector of the supplied power cable into the INLET connector on the rear panel.
2. Twist the cable connector clockwise until it locks in place. Twisting the connector also turns power on/off for that box (and any subsequent daisy-chained boxes).
3. Plug the other end of the power cable into the appropriate AC Mains power source.
4. Array will power on automatically once the AC Mains power source is switched on.

## Daisy-Chaining with Power Cable Jumpers

The LA108 and LA112 loudspeakers feature loop-thru power connection using powerCON TRUE1 connectors. The powerCON TRUE1 cable and connector system is rated for a maximum current draw of 16 amps. In most countries, this is sufficient to power a maximum of six (6) LA108 or LA112 loudspeakers from a single connection to the AC mains supply (see chart below for more details by country voltage).

When not in use, the powerCON INLETS and OUTLETS connectors located on the loudspeakers' rear panel should be covered by the available weather-resistant flaps.

Neutrik powerCON TRUE1 loop-thru cables are not included with LA108 and LA112 loudspeakers but may be purchased separately from most professional audio equipment suppliers or from QSC.

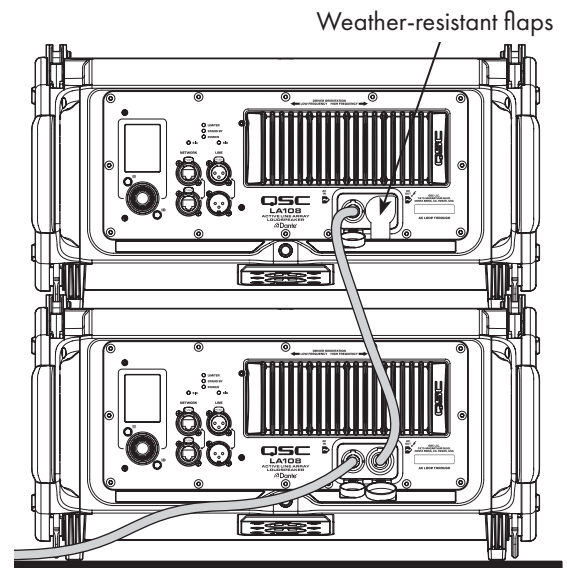

— Figure 68 —

## Compatible QSC Accessories

- LA-KIT-J (International Jumper Kit): two 60 cm PowerCon TRUE1 jumpers and two 60 cm EtherCON jumpers, 1.5 mm<sup>2</sup>/H05VV cables
- LA-KIT-J-NA (North America Jumper Kit): two 24-in PowerCon TRUE1 jumpers and two 24-in EtherCON jumpers, 12 AWG/SVT cables, NEC compliant



**WARNING!:** The amplifier AC mains power is present in the loop-thru cables. If the AC mains is connected to one LA108 or LA112 loudspeaker, electrical power is present on all connected loop-thru cables.



**WARNING!:** Do not connect more than six (6) LA108 or LA112 loudspeakers together using the jumper power cables (one AC mains power cord and five jumper cables). When using jumper power cables, make all loop-thru connections prior to connecting to the AC mains power source.

## Daisy-Chaining Procedure

1. Insert the locking POWER-OUT connector of the jumper cable (not supplied) fully into the OUTLET connector on the loudspeaker's rear panel. Twist clockwise until it locks in place.
2. Insert the locking POWER-IN connector into the INLET connector on the rear panel of the next loudspeaker in the chain. Twist clockwise until it locks in place.
3. Repeat until all loudspeakers in the array (up to six (6), using five (5) loop-thru jumper cables) are properly connected.

Please follow the table below to safely power a specific loudspeaker array.

**NOTE:** The QSC LS118 is a single 18-inch, active subwoofer, part of the L Class family of products, designed to complement LA108/LA112 loudspeakers.

Model	Input Current (Normal Use)	100V (15A Circuit)	120V (15A Circuit)	220~240V (10A Circuit)
LA108	100V = 0.8A 120V = 0.8A 220~240V = 0.5A	Up to 6x loudspeakers Total 4.8A	Up to 6x loudspeakers Total 4.8A	Up to 6x loudspeakers Total 3A
LA112	100V = 1.8A 120V = 1.5A 220~240V = 1.0A	Up to 6x loudspeakers Total 10.8A	Up to 6x loudspeakers Total 9A	Up to 6x loudspeakers Total 6A
LS118	100V = 3A 120V = 3A 220~240V = 1.5A	Up to 4x subwoofers Total 12A	Up to 4x subwoofers Total 12A	Up to 4x subwoofers Total 6A

It is also possible to mix and match subwoofers with arrayed loudspeakers when pole-mounting or ground-stacking them close together. However, the QSC LA-KIT (both J and J-/NA versions) will need to be extended with a second jumper cable or compatible Powercon TRUE1 cable to connect the uppermost subwoofer to the lowermost arrayed box.

**NOTE:** PowerCON TRUE1 cables have a plug-end and a socket-end that can be daisy chained together to create longer power connections.

## Recommended Configurations

### LA108 Loudspeaker

- 1x LS118 subwoofer with 3x LA108 loudspeakers pole mounted above (total 5.4A/100~120V or 3A/220~240V)
- 2x LS118 subwoofers with 4x LA108 loudspeakers in a ground-stack (total 9.2A/100~120V or 5A/220~240V)

### LA112 Loudspeaker

- 2x LS118 subwoofers with 2x LA112 loudspeakers pole mounted above (total 9.6A/100, 9A/120V or 5A/220~240V)
- 2x LS118 subwoofers with 3x LA112 loudspeakers in a ground-stack (total 11.4A/100V, 10.5A/120V or 6A/220~240V)



**WARNING!** Always ensure the circuit is loaded no higher than 80% of the circuit rating when daisy-chaining AC power to multiple boxes. For example, never load more than 12 Amps on a 120 V/15 A circuit, or 8 Amps on a 230 V/10 A circuit.



## Power On Sequence

1. Turn down the output levels on the mixer (or other audio source) to its minimum position.
2. Switch on all source devices (mixer, musical instruments, audio player, etc).
3. Prepare the LA108 or LA112 loudspeaker for power by twisting the locking POWER-IN connector clockwise. If the LA108 or LA112 loudspeaker are daisy-chained to other boxes, the AC POWER-IN only needs to be inserted in the first loudspeaker of the array (usually the lower unit).
4. Connect the AC mains power cable to the AC mains outlet.
5. Verify that all power connections have been made by ensuring the blue POWER indicator LED is illuminated on every single loudspeaker in the array.
6. The output level controls on the mixer/audio source may now be brought up.

## Power Off Sequence

1. Turn down the output levels on the mixer (or other audio source) to its minimum position.
2. Disconnect power from the AC mains source.
3. Disconnect the LA108 or LA112 loudspeaker power cable by pulling the connectors tab back and twisting the locking POWER-IN connector counter-clockwise. If the LA108 or LA112 loudspeaker are daisy-chained to other loudspeakers/subwoofers, then power will be disconnected to the rest of the array.
4. Verify that power connections have been disconnected on each unit. When the loudspeaker/subwoofer blue POWER indicator LED, or yellow Standby LED, is no longer illuminated and the rear screen is turned off, then it is safe to proceed.
5. Power off all source devices (mixer, musical instruments, audio player, etc.).

## Analog Audio Connections

**NOTE:** While both digital audio and analog audio connections can be physically connected simultaneously, the loudspeaker will default to digital audio if a Dante® audio connection is made, causing the analog audio inputs to be muted until the Dante® signal is disconnected. The analog connections can be used alongside a line array that is Ethernet-connected and QSC SysNav™ controlled, as standalone without SysNav control, or as a backup audio connection in the event of digital audio failure.

### XLR Connections

Each loudspeaker features a LINE IN (input) XLR and a LINE OUT (output) XLR to support daisy-chaining multiple loudspeakers/subwoofers in an array.

The LINE OUT XLR connector is wired in parallel to the LINE IN XLR connector, making it a direct pass-thru. It does not output any Post-DSP signal, nor is the level on the LINE OUT affected by the digital GAIN setting adjusted on the loudspeaker.

Using the XLR connectors, you can safely daisy-chain up to six (6) loudspeakers plus two (2) subwoofers without any signal losses.

**NOTE:** It is not recommended to use unbalanced audio connections with LA108/LA112 loudspeakers. Always use XLR balanced audio connections and wiring as shown in Figure 69.

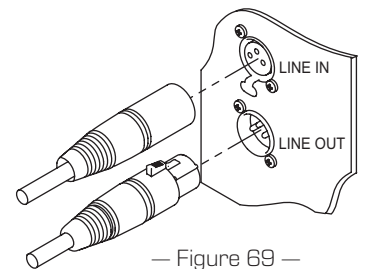

— Figure 69 —

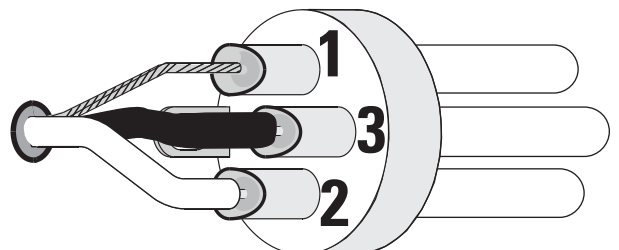

— Figure 70 —

## Daisy-Chaining with Balanced XLR Jumper Cables

1. Connect the audio source (mixer, musical instruments, audio player, etc.) to the LINE IN XLR connector (6) on the rear panel.
2. If additional units are daisy-chained in the array, connect the audio loop-thru jumper cable (not supplied) from the LINE OUT XLR connector to the LINE IN XLR connector on the next loudspeaker.
3. Continue this process until all loudspeakers in the array are connected using balanced XLR cables.

## Network Connections

The dual network connectors also support daisy-chaining multiple loudspeakers in an array. Unlike the powerCON and XLR connectors, which have dedicated input and throughput connectors, the network ports are identical switched-ethernet ports, which means either can be used as an input or as a network hop to the next unit in the array.

The network ports can accept either a rugged etherCON connector or a standard RJ45 connector; however, it is always recommended to use etherCON type connectors, rather than conventional RJ45 connectors, as the mechanical robustness and EMC performance is superior.

Each loudspeaker includes two IP addresses, one dedicated to “control” and one dedicated to “Dante audio-over-IP.” However, both control and Dante data traffic are carried over a single CAT5/6 cable into a single RJ45 port.

## Daisy-Chaining with Network Jumper Cables

There are two common methods for connecting network devices:

- a. Star Topology: With the star topology method, each device has its own port on an ethernet switch. This is the most robust method, but it requires a cable home run from each device back to the ethernet switch, which is fine for permanent installations but challenging for temporary deployments.
- b. Daisy Chain: The daisy-chain method requires dual switched ports on each device, as found on the LA108/LA112 loudspeakers. While daisy-chaining is much easier to deploy, it should be noted that each “hop” incurs a latency penalty, measured in microseconds that quickly add up. Therefore, a pre-determined latency is applied to each Dante-receiving device to account for switch hops, eliminating the risk of dropped packets and resulting audio glitches.

The Dante latency settings are based on worst-case latency assumptions and are therefore quite conservative. The LA108/LA112 loudspeakers default to 1 ms, which will accommodate up to 10 switch hops.

As a reference point, a Dante mixer connected through an ethernet switch to a 6-box daisy-chained array of LA108 or LA112 loudspeakers is the equivalent of 6 switch hops.

If 5 switch hops or less are used, there is the potential to adjust the latency down from 1 ms to 0.5 ms using the Dante Controller software. Please refer to Audinate for more information on Dante Controllers.

For ethernet daisy-chaining, the optional LA-KIT-J or LA-KIT-J-NA jumper kit mentioned above is needed (refer to the Accessories section for more information).

## Connecting to a Network

1. Connect the network source (router, switch, or computer) to the RJ45 jack on the rear panel using a CAT5/6 cable (not supplied).
2. If using the RJ45 loop-thru connections, connect another CAT6 cable to the available RJ45 port on the first loudspeaker and connect the open-end connector to the RJ45 input on the next loudspeaker.
3. Continue this process until all loudspeakers in the array are connected using RJ45 digital connections.

## Network Control

There are two modes of operation using network control:

- a. **Simple Mode:** This mode duplicates all the functionalities of the loudspeaker's Rear User Interface (RUI) as described in the following chapters. Simple mode allows users to connect an Ethernet cable to just one single loudspeaker. Low data communication to the other loudspeakers in the array is managed via wireless transmission (QSC AWARE™).

**NOTE:** Simple mode is not recommended for loudspeaker firmware updates. The recommended method is to use a wired Ethernet connection to each loudspeaker.

- b. **Advanced Mode:** This mode offers greater functionalities, but requires an Ethernet network connection to every loudspeaker in the array. When all loudspeakers in the array are discovered on the network, Simple Mode is disabled and each loudspeaker only displays its unique IP address.

## Dante® Audio Setup

Each array of loudspeakers can subscribe to a Dante audio-over-IP Transmitter (TX), sent over the network from common audio sources, such as a digital mixing console or a QSC Q-SYS Core. Dante subscriptions can be set up using one of two methods:

- a. **QSC SysNav™ (System Navigator):** This Windows application is available from QSC.com and allows the user to view all Dante Transmitters (TX) discovered on the network and then subscribe a loudspeaker (or array of loudspeakers) to that transmitter.
- b. **Dante Controller:** This Windows or macOS application is available from Audinate.com and provides users with more advanced tools to manage Dante traffic.

## Cooling

The LA108 and LA112 models are internally powered loudspeakers that contain Class D power amplifiers, which produce some heat.

- Allow a minimum of 15 cm (6 inches) clearance at the rear of the enclosure for cooling.
- Do not restrict airflow to the rear of the loudspeaker enclosure.

## Outdoor Installations



### CAUTION!:

- Do not install LA108/LA112 loudspeaker enclosures with their rear panels exposed to direct sunlight. Direct sunlight will heat the amplifier module and reduce its ability to produce full output. Install sunshades if the application merits. Maximum ambient temperature for full performance to specification is 50° C (122° F).
- Do not install enclosures with exposure to rain or other water sources. The enclosure is not weatherproof. Outdoor installations must provide protection from the elements.

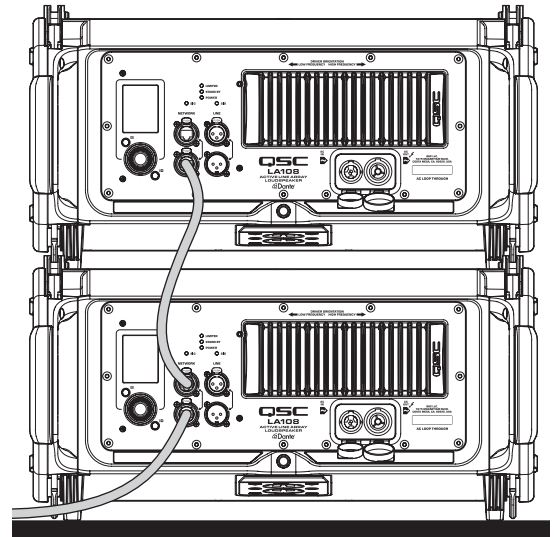

— Figure 71 —

# Rear Panel User Interface

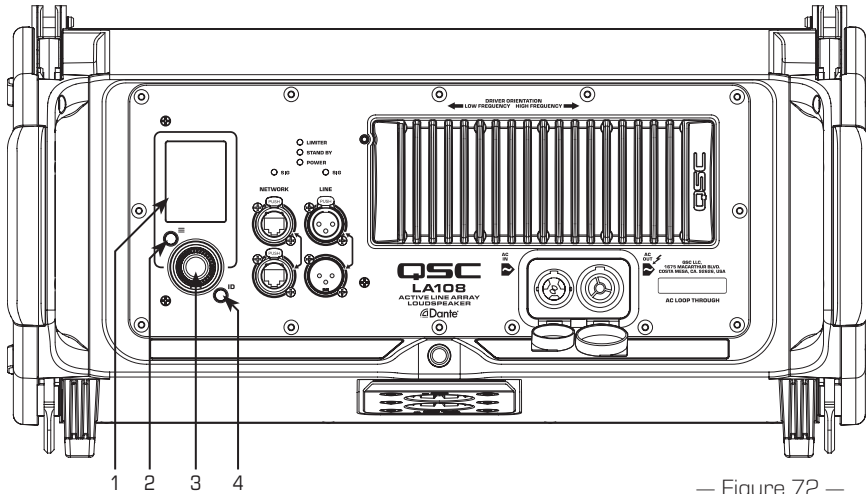

— Figure 72 —

1. Displays Menus and Settings
2. Push to enter the Menu, or return to Home Screen from Menu
3. Rotate to adjust gain, select values, and press for enter
4. Push to ID loudspeaker in QSC SysNav™ or Q-SYS Ecosystem

## Navigating the Rear User Interface

When first unpacking LA108 or LA112 active line array loudspeakers, make sure to download the latest loudspeaker firmware as well as the latest version of the QSC SysNav™ (System navigator) App from QSC.com.

### Menu Map

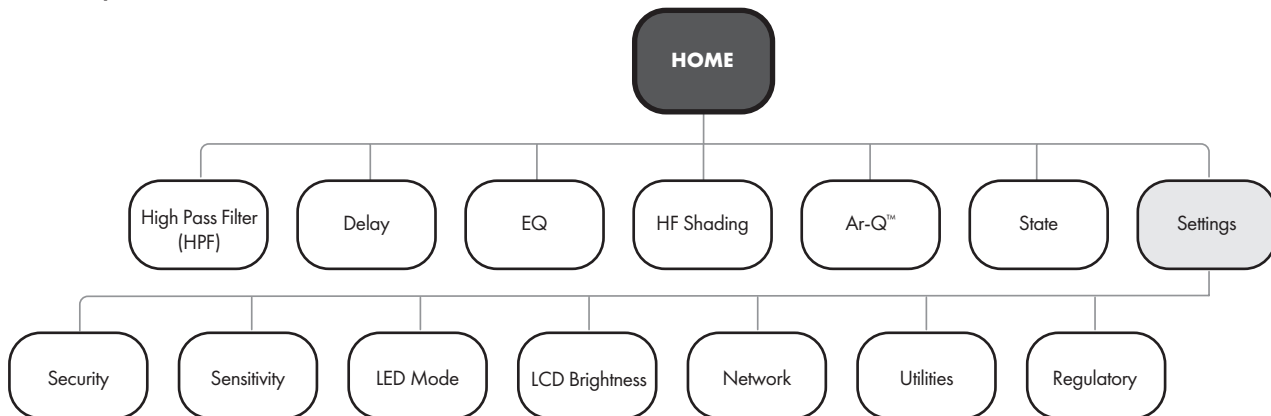

— Figure 73 —

## Home Screen

The Home screen is visible after the loudspeaker has powered on and booted up completely. If any changes are made via the user interface, you can always return to the Home screen from any menu parameter by pressing the Menu button twice, or waiting 30 seconds.

1. Rotate to adjust gain on HOME screen or select values in the MENU. Press to confirm a selected value. This press-knob is also used to engage QSC AWARE™ array optimization.
2. Press to access the MENU from the HOME screen, or press while in the MENU to return to the HOME screen
3. Press ID button to identify loudspeaker location when connected to QSC SysNav™ or Q-SYS Ecosystem
4. Information on Array Name and Status
5. Displays the security lock status of the loudspeaker
6. Splay angle between arrayed loudspeakers
7. Total number of detected loudspeakers
8. HF Shading applied to each arrayed loudspeaker
9. Current Gain level for the loudspeaker
10. Network icon displays if the loudspeaker is connected to an active network
11. Displays status of Ar-Q™ Array Equalization DSP
12. Displays status of the High-Pass Filter
13. Displays status of the on-board EQ
14. Displays current Input Sensitivity setting

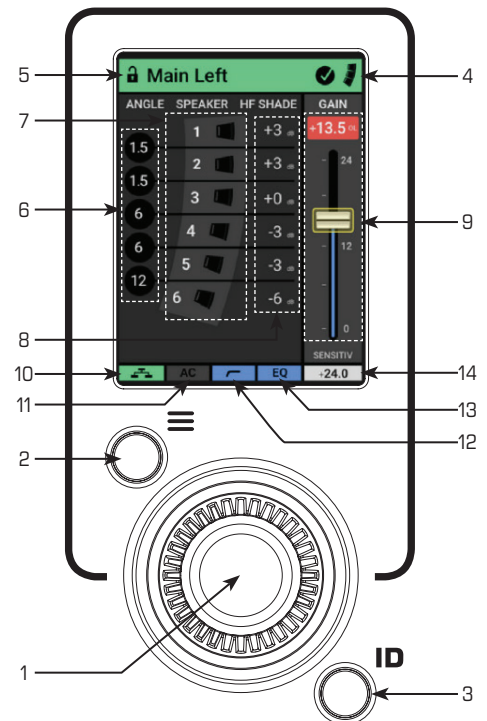

— Figure 74 —

## Home Screen Status

Utilizing infrared technology, LA108 and LA112 active line array loudspeakers can sense the state of other array member loudspeakers, as well as the state of the entire array at any given point in time. Based on the state of the array, the top bar will show the following colors to verify the array status at a glance.

## Top Bar

- Green: The array is optimized, and working in its factory-recommended state for the deployment it is currently in. If more than one box is present, grouped functions like Gain, Ar-Q™ Array Equalization, High-Pass Filter, EQ, Delay, and Input Sensitivity can all be adjusted from a single loudspeaker for the entire array.
- Orange: The Array is not optimized due to a mismatch of parameters from the loudspeakers' last known state. Grouped functions will not operate together, and each loudspeaker must be adjusted manually via its individual user interface. In this state, the array can be optimized again by simply pressing the rotary controller for three (3) seconds, which will set the array to a factory-optimized state, returning the status to green.
- Red: A hardware failure has been detected. Remove the faulty loudspeaker from the array and run the Diagnostic test available in the menu. If necessary, bring the faulty loudspeaker to a QSC Authorized Service Center.

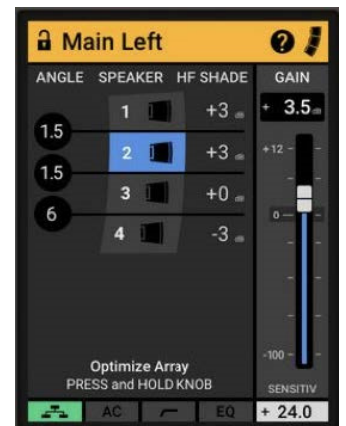

— Figure 75 —

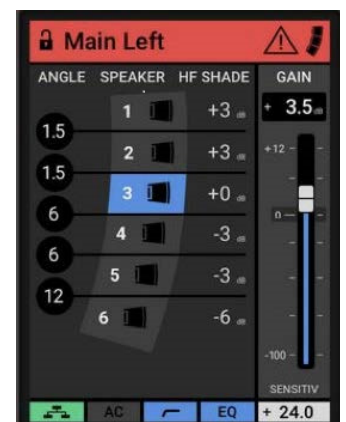

— Figure 76 —

## Network Icon

- **Green:** The loudspeaker is connected to a functioning network.
- **Grey:** The loudspeaker has not been connected to a functioning network since its last power cycle.
- **Red:** The loudspeaker was previously connected to a functioning network since its last power cycle but has lost connection to that network.

## Ar-Q™ (Array Equalization)

- **Blue:** Array equalization is engaged, and the current compensation is correct for the array deployment.
- **Orange:** Array equalization is engaged, but the current compensation is not correct for the array deployment.
- **Grey:** Array equalization has been defeated.

**NOTE:** AC can only be defeated when loudspeaker/array is connected to QSC SysNav software app.

**NOTE:** For QSC AWARE to function, the maximum number of LA108 or LA112 loudspeakers in any array is six (6). Any arrays larger than 6 will require manual voicing setup (see Ar-Q™ section).

## High-Pass Filter

- **Blue:** The high-pass filter is engaged and matches all loudspeakers in the array.

**NOTE:** Default is 80 Hz for use with L Class and KS Series subwoofer; however, a 100 Hz setting is available to be used with legacy QSC KW181/KLA181 subwoofers.

- **Orange:** The high-pass filter is engaged, but it does not match the high-pass filter set in the rest of the array.
- **Grey:** High-pass filter has been defeated, and the loudspeaker is operating in its full-range state.

## EQ

- **Blue:** The EQ is engaged, and it matches the EQ set in the rest of the array.
- **Orange:** The EQ is engaged, but it does not match the EQ set in the rest of the array.
- **Grey:** The EQ has been defeated.

**NOTE:** EQ parameters can only be adjusted via QSC SysNav software app.

## Menu

The menu can be accessed from the Home Screen by pressing the Menu button once, which will provide access to the following parameters:

- **High-Pass Filter:** 80 Hz or 100 Hz
- **Delay:** 0 – 200 ms
- **EQ:** In or Bypassed (User EQ adjustment requires the QSC SysNav software app)
- **HF Shading:** -6 dB to +3 dB
- **Ar-Q™ (Array Equalization):** Factory voicing optimization of the deployed array. These parameters are set automatically when the array is **optimized** but can be defeated and set manually in the event of a hardware failure of the infrared communication links.
  - **Box Count:** The number of loudspeakers in an array.
  - **Box Number:** The location of the loudspeaker in the array. In a 6-box array, 1 is the top, and 6 is the bottom.
  - **Total Splay:** The sum of the total splay angles between the array loudspeakers (do not count the Array Frame or Sub-Stack angle).

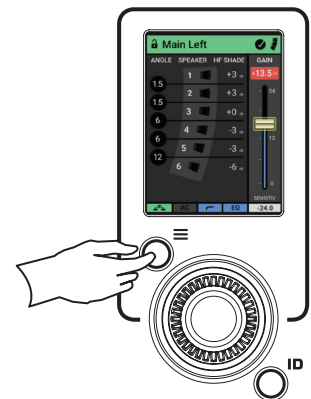

— Figure 77 —

- **Confirm:** Once you have manually entered the Ar-Q values, select the Confirm button and press the encoder to apply the settings.
- **Splays:** When you manually select the Box Count, Box Number, and Total Splay, you will see the correct splay angle for your array listed in the Splays window. The angles read left to right are the angles of the loudspeakers in the array from top to bottom.

## Settings

This menu contains important, but less frequently viewed, loudspeaker parameters.

- **Security:** A 4-digit code can be entered to lock the loudspeaker settings from being adjusted, until the code is re-entered. After a code has been entered and the loudspeaker is locked, the user interface will return to the Home Screen, and a lock icon will be displayed in the upper left-hand corner.
- **Sensitivity:** Determines the signal level needed to drive the loudspeaker to maximum output.
  - **+24 dBu:** For use with high-output, professional mixing consoles (using typically XLR connectors).
  - **+4 dBu:** For use with low-output mixing consoles or audio interfaces (using typically 6.35 mm [1/4-in] TRS or RCA connectors)
- **LED Mode:** Front and Rear lit, Front only, Rear only, Blackout (all out).
- **LCD Brightness:** Adjusts LCD screen brightness for light or dark environments.
- **Network:** Displays network IP address and subnet for QSC SysNav connection, as well as IP address, subnet, and TX Source for the Dante® network connection. DHCP or static IP address can also be selected.

## Utilities

- **Diagnostic Test:** An isolated tone is played separately through the low frequency and high frequency drivers to validate if it is functioning. If no tone is heard through either driver, contact a local QSC Service Center for assistance.
- **Factory Reset:** Returns all loudspeaker settings to factory default state.
- **Re-calibrate Angle:** On rare occasions (after service, accidental shock, etc.), the internal accelerometer may need to be re-calibrated. Place the loudspeaker on a known, level surface and run this re-calibration process. It is best to re-calibrate all loudspeakers on the same surface for consistency.

**NOTE:** When re-calibrating the accelerometer, make sure no audio is connected or playing through the loudspeaker.

- **Regulatory:** Statements for regional regulatory compliance.

## Additional Functions

- **ID Button:** When connected to System navigator, the ID button can be pressed to locate the speaker in the design. The resulting speaker will flash in the design for 30 seconds or until the ID button is pressed again.
- **Factory Reset Shortcut:** With the loudspeaker powered on, press and hold the MENU and ID buttons simultaneously for 3 seconds to initiate a factory reset.

## DSP Features

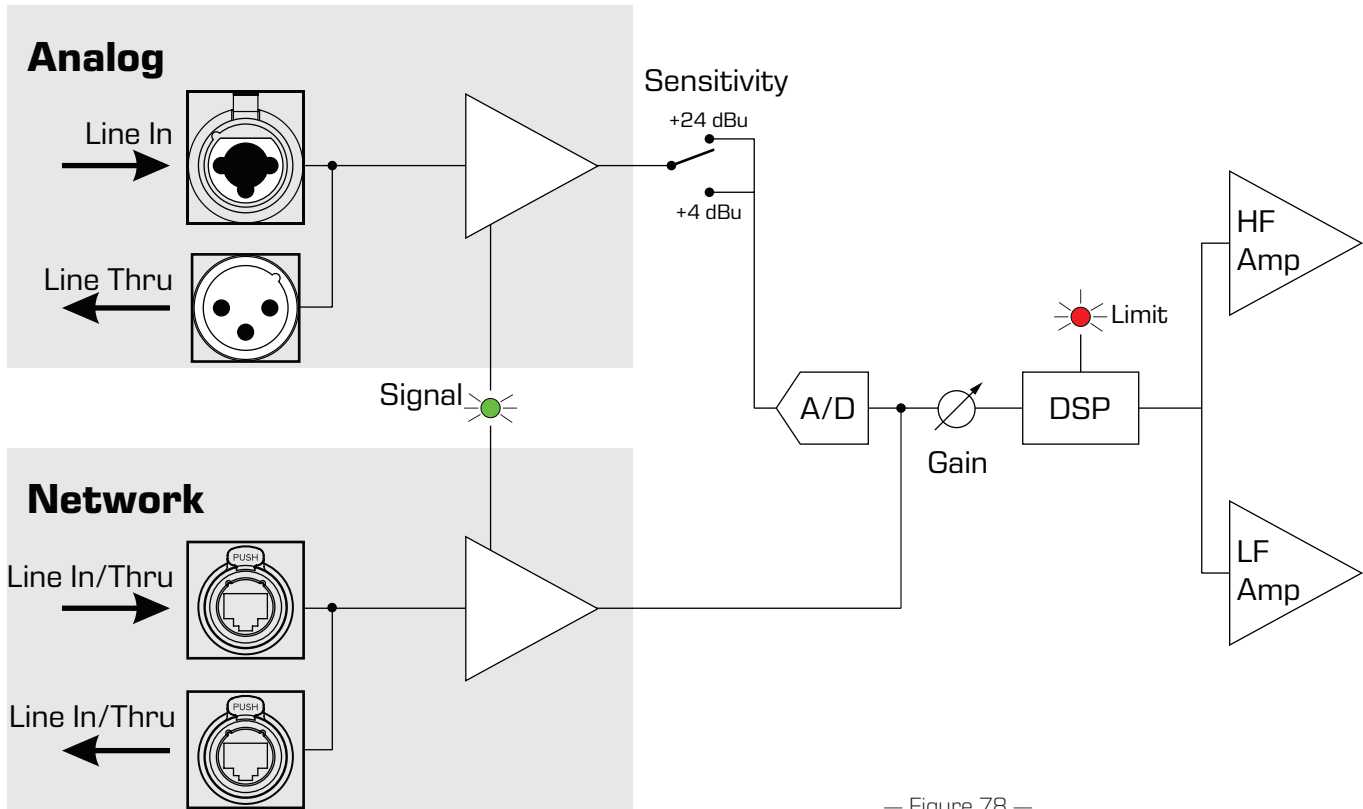

— Figure 78 —

## L Class Accessories

### Transportation

Both the LA108 and LA112 are designed to be highly mobile. Heavy-duty Cordura Tote accessories are available for each model.

<b>LA108-TOTE</b>	Heavy-duty Cordura Transport Tote with Velcro flap
<b>LA112-TOTE</b>	Heavy-duty Cordura Transport Tote with Velcro flap

### Interconnect Jumpers

**NOTE:** The jumper kits below do not include short analog XLR cables, as these are readily available.

### Between Loudspeakers

Both the LA108 and LA112 use the same interconnecting jumper cables for AC power and networking. When creating arrays of two or more boxes, the LA-KIT-J jumper kit is required (depending on home country):

<b>LA-KIT-J</b>	International Jumper Kit (includes 2x 60 cm EtherCON jumpers / 2x 60 cm PowerCON TRUE1 jumpers with 1.5 mm <sup>2</sup> /H05VV cables)
<b>LA-KIT-J-NA</b>	North-America Jumper Kit (includes 2x 24-in EtherCON jumpers / 2x 24-in PowerCON TRUE1 jumpers with 12 AWG/SVT cables, NEC compliant)

- If there are two (2) boxes on either side of the stage, one (1) jumper kit is required.
- If there are three (3) boxes on either side of the stage, two (2) jumper kits are required.



## Temporary Outdoor Use

The L Class products may be deployed outdoors on a temporary basis (music festivals, events, etc.). While the enclosures and power connectors are IP rated, extra caution should always be taken in case of inclement weather. For these situations, it is recommended to use the Temporary Weather Shield accessory to cover the Rear I/O's situated on the loudspeakers' rear panel.

<b>TWS-IO</b>	Temporary Weather Shield covers input/output section of each LA108/LA112
---------------	--

## Sub-stacking

### LA108 Loudspeaker

The LA108 loudspeaker can be stacked over the LS118 subwoofer (upright or on its side), the KS118 (upright only), or the KS212C (on its side only). For stack deployment over these subwoofers, the following accessories are required:

<b>LA108-AF</b>	Array Frame for LA108
<b>LA108-KIT-SA</b>	Stack Adapter Kit (includes 2x metal plates and hardware to be attached to LA108-AF array frame)

### LA112 Loudspeaker

The LA112 loudspeaker can only be stacked over the LS118 subwoofer on its side. To stack over this subwoofer, the following accessories are required:

<b>LA112-AF</b>	Array Frame for LA112
<b>LA112-KIT-SA</b>	Stack Adapter Kit (includes 2x metal plates and hardware to be attached to LA112-AF array frame)

## Flown (Portable or Installed)

The LA108 and LA112 loudspeaker can each be flown in an array of up to six (6) boxes. It is recommended to use the following Array Frame accessories:

<b>LA108-AF</b>	Array Frame for LA108
<b>LA112-AF</b>	Array Frame for LA112

## Flown (Installed Only)

For cost-sensitive installations, the LA108 and LA112 loudspeakers can each be flown in a smaller array of up to three (3) boxes when using the following Installation Kit:

<b>LA-KIT-I</b>	Installation Kit for LA108/LA112 (includes 2x Shackle Adapters and 1x Pullback Eyebolt)
-----------------	---

## Additional Information

### Care and Maintenance

The LA108 and LA112 do not contain user-serviceable parts. QSC does not recommend using chemicals or solvents to wash loudspeakers. Instead, use a damp towel with water only, and dry immediately after wiping down. Do not allow water to pool on the rigging, hardware, or rear user interface.

If exposed to direct sunlight for extended periods of time, the hardware and ABS parts may become discolored or faded. Cover or shade your LA108 or LA112 loudspeakers from long-term, direct sunlight whenever possible.



## QSC Self Help Portal

Read knowledge base articles and discussions, download software and firmware, view product documents and training videos, and create support cases.

<https://qscprod.force.com/selfhelpportal/s/>

## Customer Support

Refer to the Contact Us page on the QSC website for Technical Support and Customer Care, including their phone numbers and hours of operation.

<https://www.qsc.com/contact-us/>

## Warranty

For a copy of the QSC Limited Warranty, visit the QSC, LLC., website at [www.qsc.com](http://www.qsc.com).

© 2025 QSC, LLC. All Rights Reserved.

QSC, LLC's trademarks include but are not limited to QSC® and all trademarks are listed under [www.qsc.com/trademarks](http://www.qsc.com/trademarks), some of which are registered in the U.S. and/or other countries.