

W0098 - Steel Caster Plate

*Steel Plate with Integrated
Threads to mount casters*

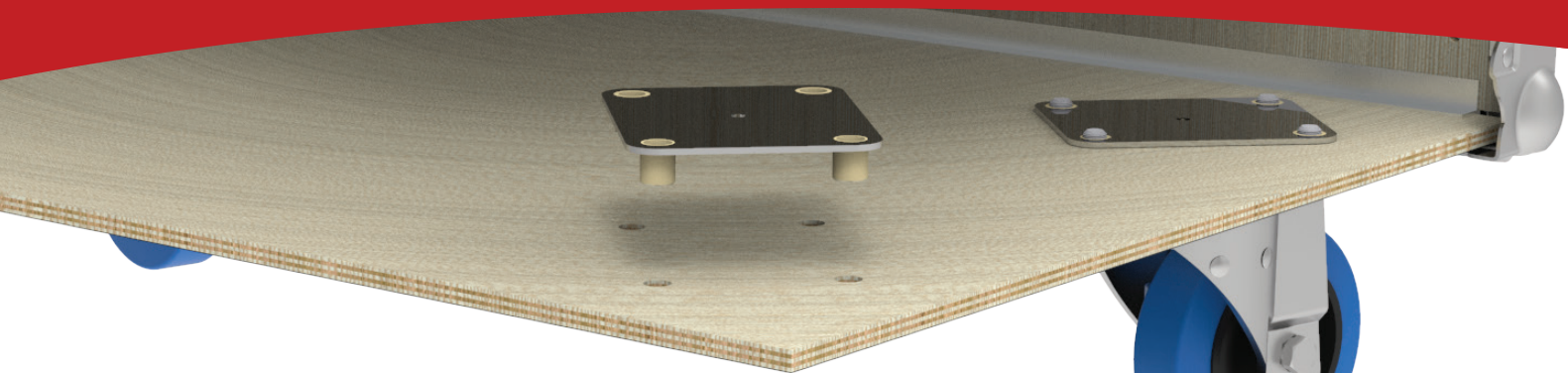

**With Integrated
threads to
mount casters**



Scan to Watch

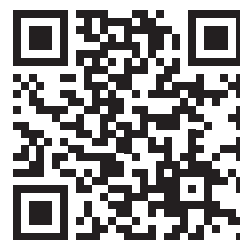

Our Video

Or Visit:

youtu.be/_0hV4jb0z_0



With this innovative new castor plate there's no longer a need for a large and heavy castor board.

Castors bolt directly through the wheel plate into the W0098-FM's integrated

M8 threads or 3/8-16UNC threads with no need for any t-nuts.

Significantly reduce your overall case weight and speed up fixing time with this new system ideal for fast or automated production.

- **No T-Nuts Required**
- **Huge Time and Cost Saving**
- **Ideal for Automated Production**

W0098-FM (M8 Thread)

W0098-FM-UNC (3/8-16UNC Thread)

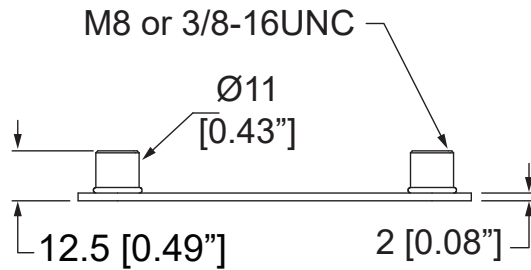
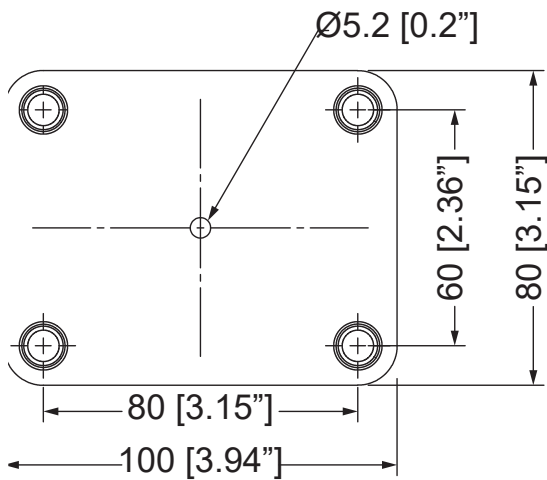

Fit castors:

75mm / 3" Castors

W0975/80	W0980
W0990/80	W0980/B
W0985/80	W0981

100mm / 4" Castors

W0990-AUTO	W0975-V6	W9004-V6	OBR100/LP PENN
W0985-AUTO	W0990-V6	W9000-V6	OBR100/LPTB PENN
W9000-AUTO	W0985-V6	W9008-V6	
W9008-AUTO			

125mm / 5" Castors

W8992

W0098CZ (#2 castor top plates / 3/8-16UNC Thread)

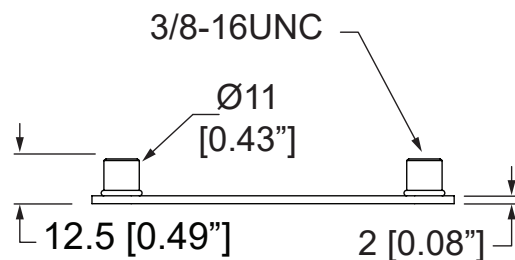
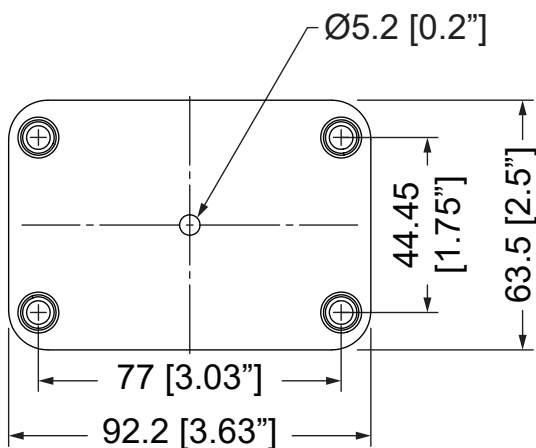

Fit castors:

90mm / 3.5" castors

6355SR	3075	1352Z210
6355SRTB	3075TB	1352Z210TB

100mm / 4" Castors

3175
3175TB