

Single Column Bottom Rigging

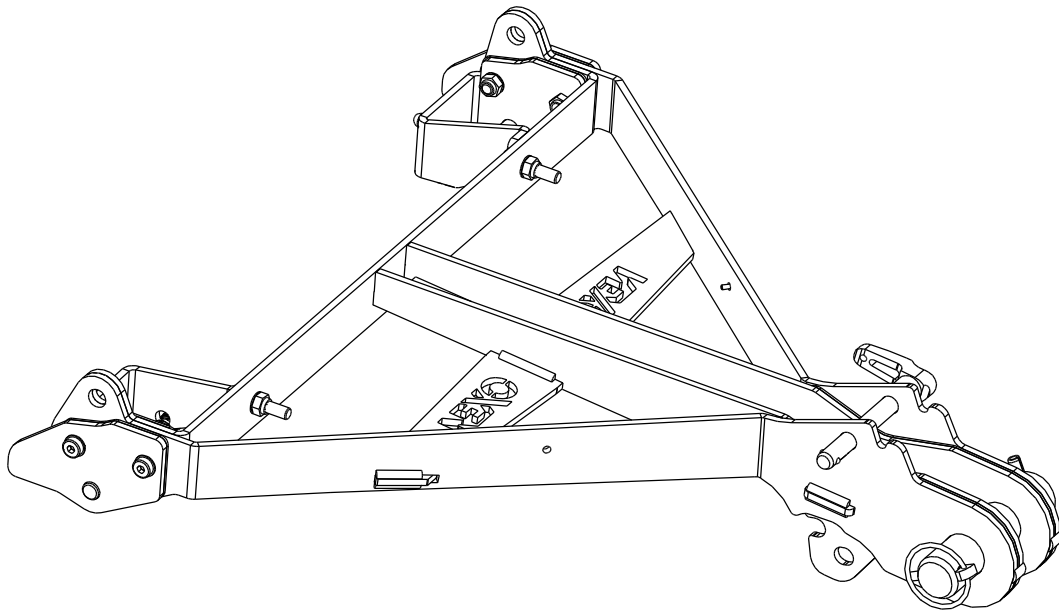
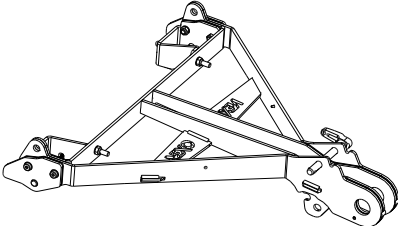
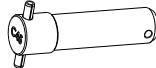
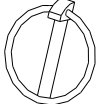

Contents:

 <p>X1</p>	 <p>X1</p>	 <p>X1</p>
---	---	---

Weight: 10 kg / 22 lb

Dimensions:

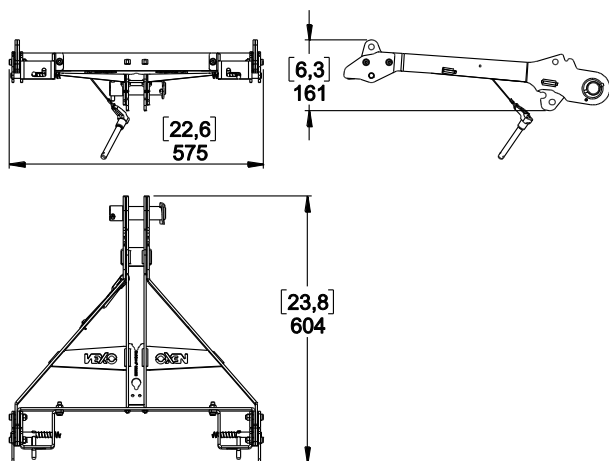

Assembly with M28 and M46/B112:

Align BTBUMPER to bottom cabinet side rigging slots, and lock the BTBUMPER to bottom cabinet by pushing RedLock™.

- M28:

Rotate Compass to BTBUMPER connection point, and insert the quick release pin.

Lift BTBUMPER so that it is adjacent to bottom cabinet and lock them with the quick release pin into BTBUMP hole.

- M46/B112:

Slide PistonRig™ to BTBUMPER connection point by rotating lock handle in OPERATION mode (vertical position), and insert the quick release pin.

Turn PistonRig™ wheel to ■ parking position.

Lift BTBUMPER so that it is adjacent to bottom cabinet and lock them by turning lock handle in STORAGE mode (horizontal position).

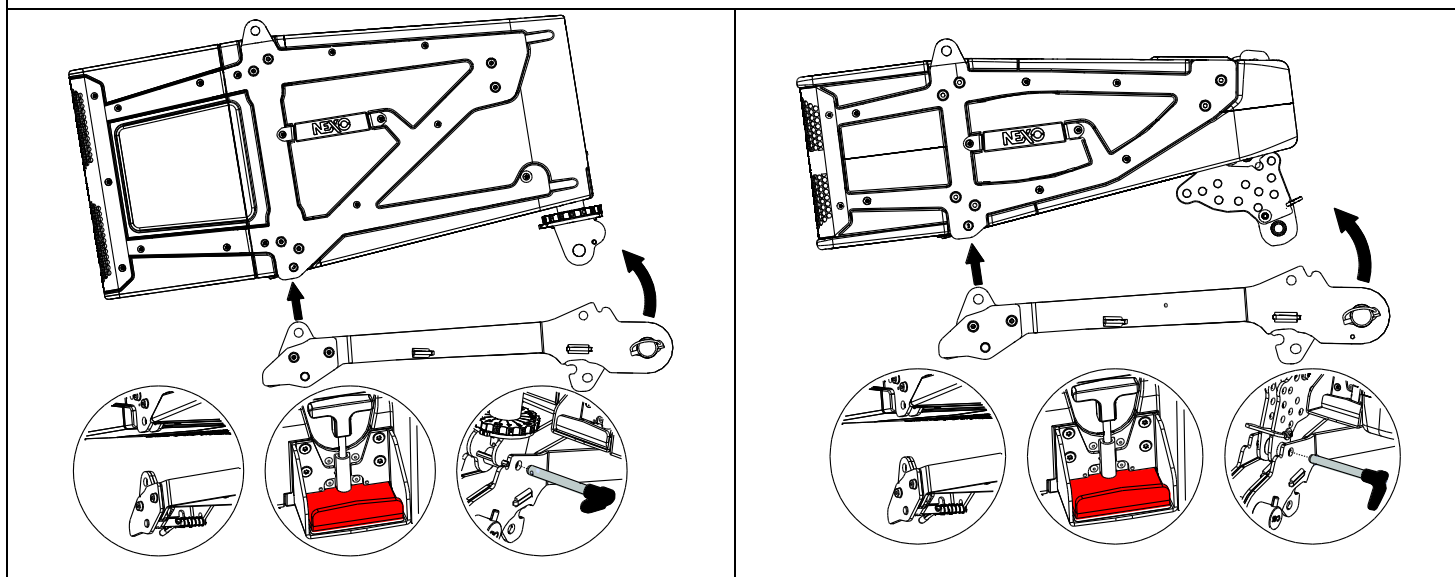

Ensure RedLock™ safety pins are locked into handle holes.

Check rear quick release pins are fully engaged and locked

NEXO

nexo-sa.com
ZA du Pre de la Dame Jeanne
60128 PLAILLY - France

- Read this document before using.
- Keep this document.
- Observe all warnings and cautions.



Assembly with S118 for stacking

- Insert BTBUMPER into the 3 fixing points, 2 on the side and one at the back.
- Lock the lateral spring pins located inside the BTBUMPER to the front lateral holes.
- Insert quick release pin at the back.

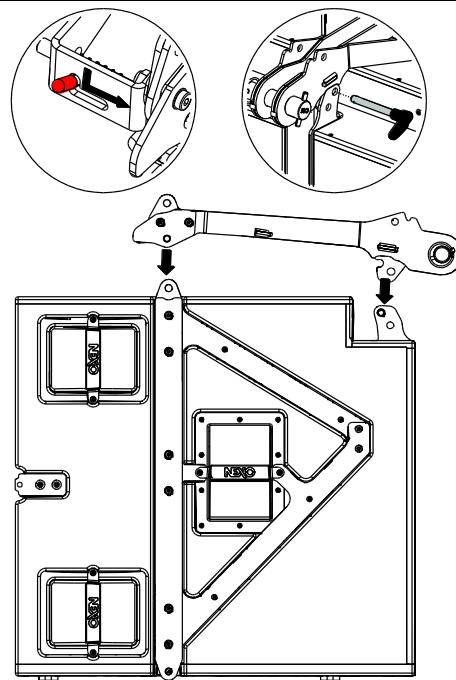

Tilt

B112 / M46

Adjust the tilt (Negative or positive) with the PistonRig™.
Range $\pm 5^\circ$

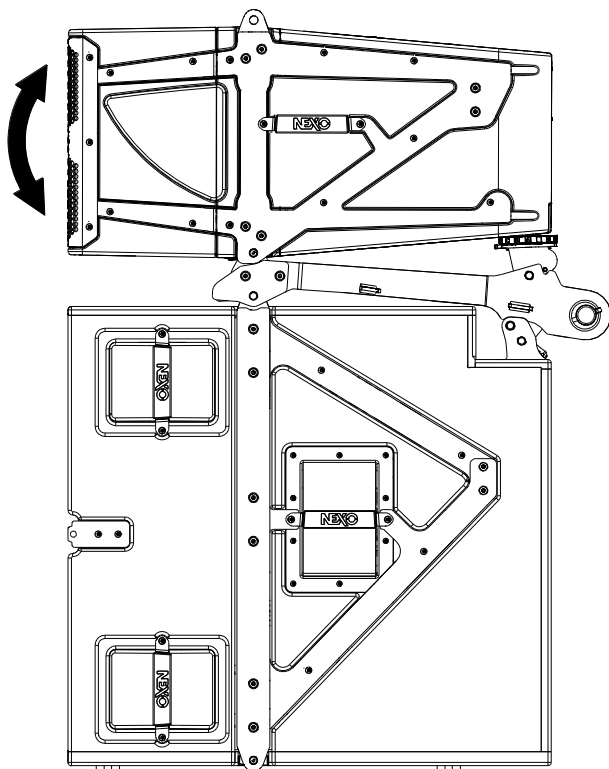

M28

Adjust the tilt (Negative or positive) with the Compass.
Range -5° to $+10^\circ$

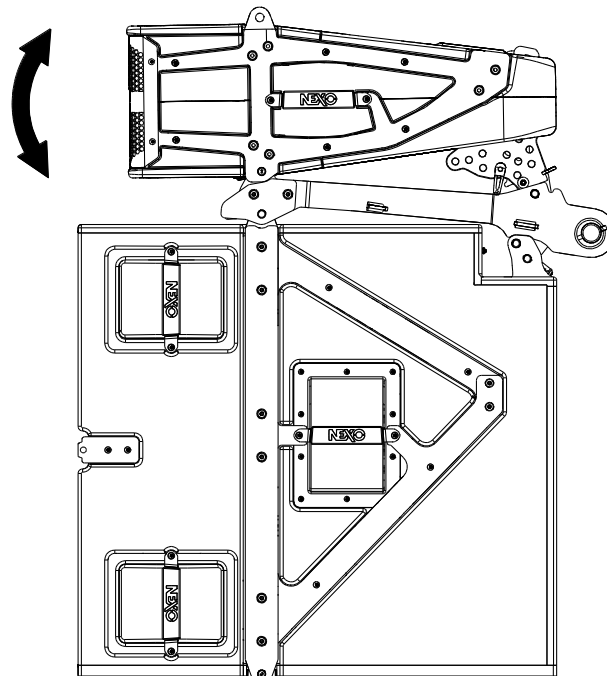

NEXO

nexo-sa.com
ZA du Pre de la Dame Jeanne
60128 PLAILLY - France

- Read this document before using.
- Keep this document.
- Observe all warnings and cautions.



Assembly with VXT-LIKM

- Insert the laser/clinometer into the slots, and push to lock it.
- To remove the laser/clinometer, pull up the latch and pull it back.

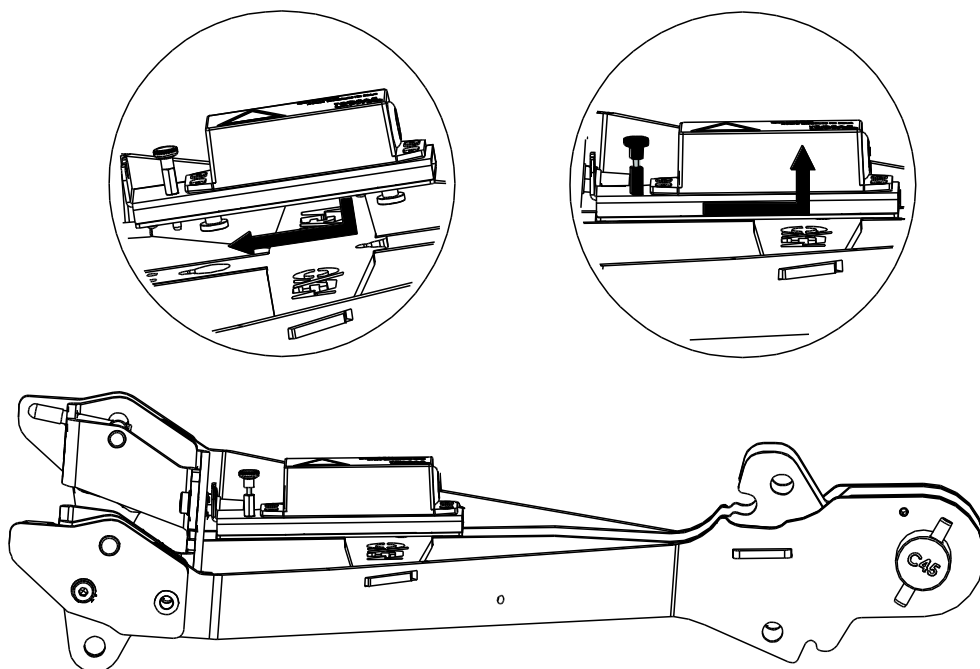

- NEXO cannot accept responsibility for accidents caused by any factor other than defects in this product itself.
- Please check the web site nexo-sa.com for the latest update.

NEXO

nexo-sa.com
ZA du Pre de la Dame Jeanne
60128 PLAILLY - France

- Read this document before using.
- Keep this document.
- Observe all warnings and cautions.

