

### Flanges 120° for GEOM10

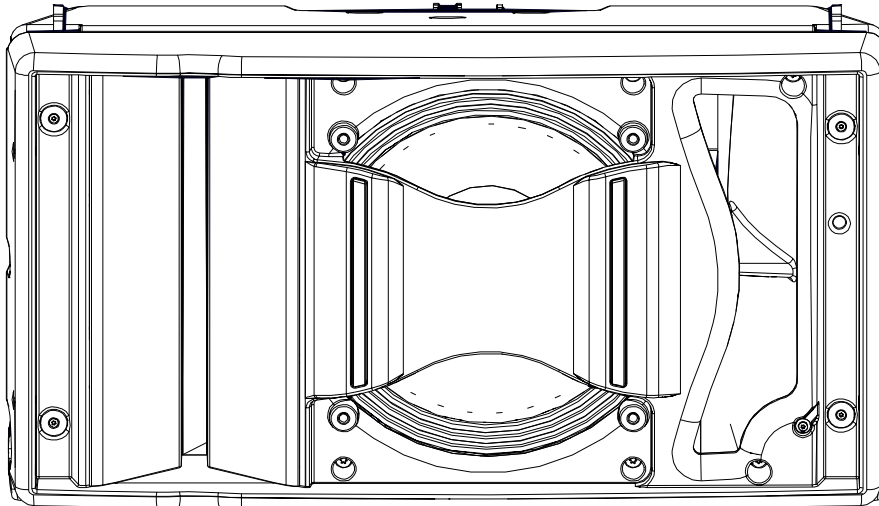

#### Contents:

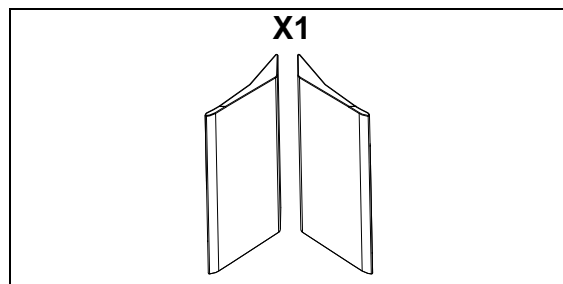

**Weight: 0.3 kg / 0.7 lb (pair)**

## Use:

### Implementation

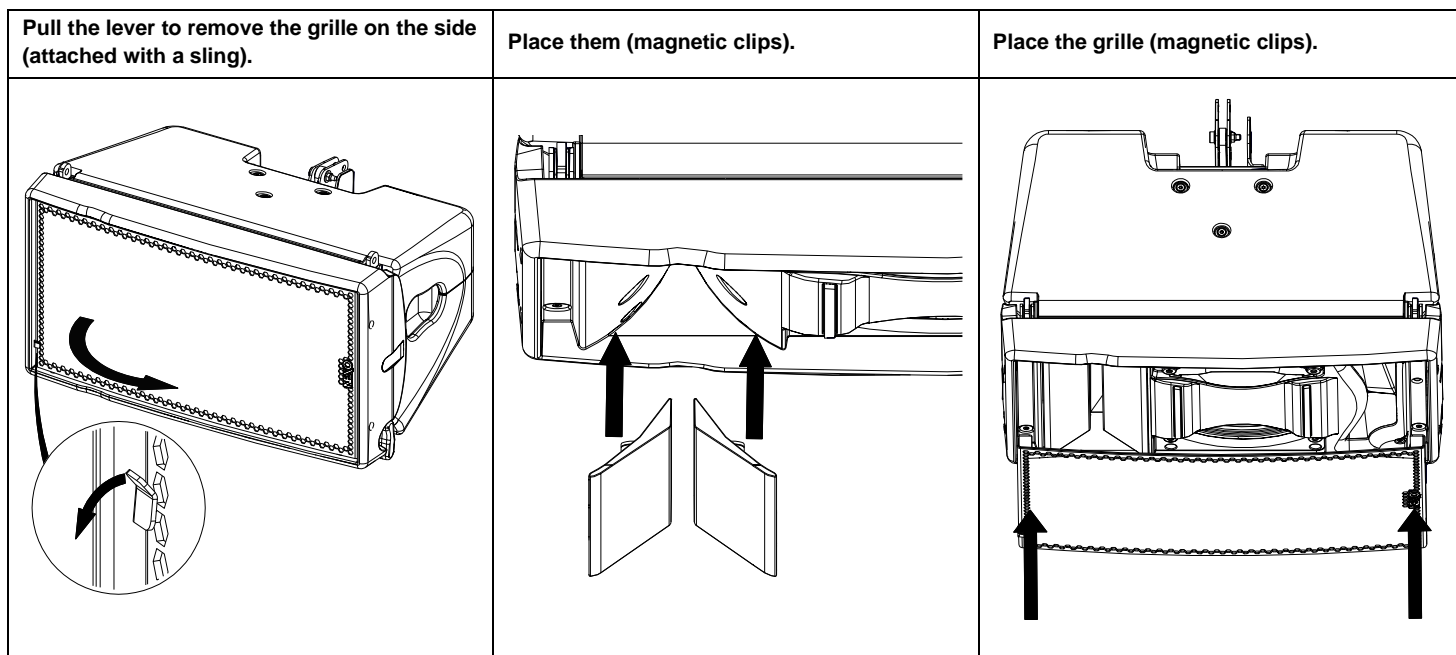

### Disassembly

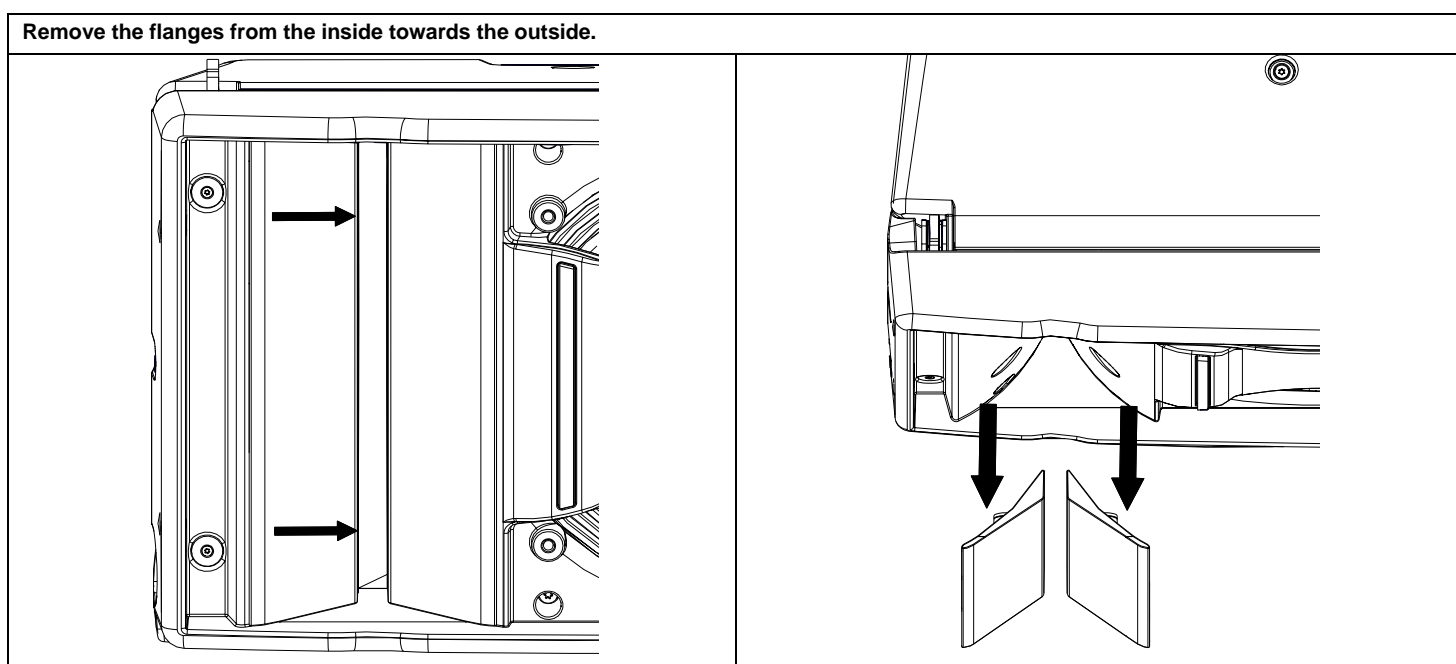

- NEXO cannot accept responsibility for accidents caused by any factor other than defects in this product itself.
- Please check the web site [www.nexo-sa.com](http://www.nexo-sa.com) for the latest update.

# NEXO

www.nexo-sa.com

ZA du pre de la Dame Jeanne

60128 PLAILLY-France

- Read this document before using.
- Keep this document.
- Observe all warnings and cautions.