



RM Quartet

UHF Radio Microphone System

User Manual



Order code: MIC80

WARNING

FOR YOUR OWN SAFETY, PLEASE READ THIS USER MANUAL CAREFULLY BEFORE YOUR INITIAL START-UP!

- Before your initial start-up, please make sure that there is no damage caused during transportation.
- Should there be any damage, consult your dealer and do not use the equipment.
- To maintain the equipment in good working condition and to ensure safe operation, it is necessary for the user to follow the safety instructions and warning notes written in this manual.
- Please note that damages caused by user modifications to this equipment are not subject to warranty.



IMPORTANT:

The manufacturer will not accept liability for any resulting damages caused by the non-observance of this manual or any unauthorised modification to the equipment.

- Never let the power cable come into contact with other cables. Handle the power cable and all mains voltage connections with particular caution!
- Never remove warning or informative labels from the unit.
- Do not open the equipment and do not modify the unit.
- Do not connect this equipment to a dimmer pack.
- Do not switch the equipment on and off in short intervals, as this will reduce the system's life.
- Only use the equipment indoors.
- Do not expose to flammable sources, liquids or gases.
- Always disconnect the power from the mains when equipment is not in use or before cleaning! Only handle the power-cable by the plug. Never pull out the plug by pulling the power-cable.
- Make sure that the available voltage 12-18V DC, 500mA. (240V AC~50Hz power supply included)
- Make sure that the power cable is never crimped or damaged. Check the equipment and the power cable periodically.
- If the equipment is dropped or damaged, disconnect the mains power supply immediately and have a qualified engineer inspect the equipment before operating again.
- If the equipment has been exposed to drastic temperature fluctuation (e.g. after transportation), do not connect power or switch it on immediately. The arising condensation might damage the equipment. Leave the equipment switched off until it has reached room temperature.
- If your product fails to function correctly, stop use immediately. Pack the unit securely (preferably in the original packing material), and return it to your Pro Light dealer for service.
- Only use fuses of same type and rating.
- Repairs, servicing and power connection must only be carried out by a qualified technician. THIS UNIT CONTAINS NO USER SERVICEABLE PARTS.
- This fixture is for professional use only - it is not designed for or suitable for household use. The product must be installed by a qualified technician in accordance with local territory regulations. The safety of the installation is the responsibility of the installer. The fixture presents risks of severe injury or death due to fire hazards, electric shock and falls.
- **WARRANTY:** One year from date of purchase.

OPERATING DETERMINATIONS

If this equipment is operated in any other way, than those described in this manual, the product may suffer damage and the warranty becomes void. Incorrect operation may lead to danger e.g: short-circuit, burns and electric shocks etc.

In case of malfunction this unit should be returned for service or inspection.

Do not endanger your own safety and the safety of others!

Incorrect installation or use can cause serious damage to people and/or property.

RM Quartet UHF Radio Microphone System

The RM Quartet wireless microphones are designed for numerous applications, including vocals and public address where up to four handheld transmitters are required. Robust design allows them to withstand the stresses of the road making them perfect for karaoke, entertainers and amateurs alike. The rack mountable receiver features four balanced XLR outputs, one for each channel plus one mixed output via an unbalanced 6.35mm (1/4") jack. The receiver features a USB 5V power outlet for charging the handheld receivers with the supplied USB cable.

- 4 x handheld transmitters, each with colour code ring
- Four channel, metal UHF receiver
- LED status indicators
- Removable 19" rackmount brackets
- 4 x balanced XLR outputs
- 1 x unbalanced 6.35mm jack mixed output
- 6.35mm (1/4") jack to jack patch cable
- USB charging (2 at a time) via supplied USB cable
- Dual squelch circuit
- CH70 license free operation



In the box:
1 x receiver,
4 x wireless microphones,
1 x PSU,
2 x rack ears,
1 x USB charging mic cable,
1 x audio lead
& 1 x user manual

Specifications	RM Quartet UHF Radio Microphone System
Operating frequency	863.42Mhz / 864.99Mhz / 864.30Mhz / 863.01Mhz
AF output impedance	2.2K Ohms
Maximum output level (balanced)	0-400mV
Maximum output level (unbalanced)	0-200mV
Total harmonic distortion	less than 0.5% @1KHz
Frequency response	40Hz-18KHz
Power supply	DC 12-18V, 500mA (14V, 1.2A adaptor supplied)
Receiver dimensions (H x W x D)	45 x 420 x 220mm
Weight	3.8kg
Order code	MIC80

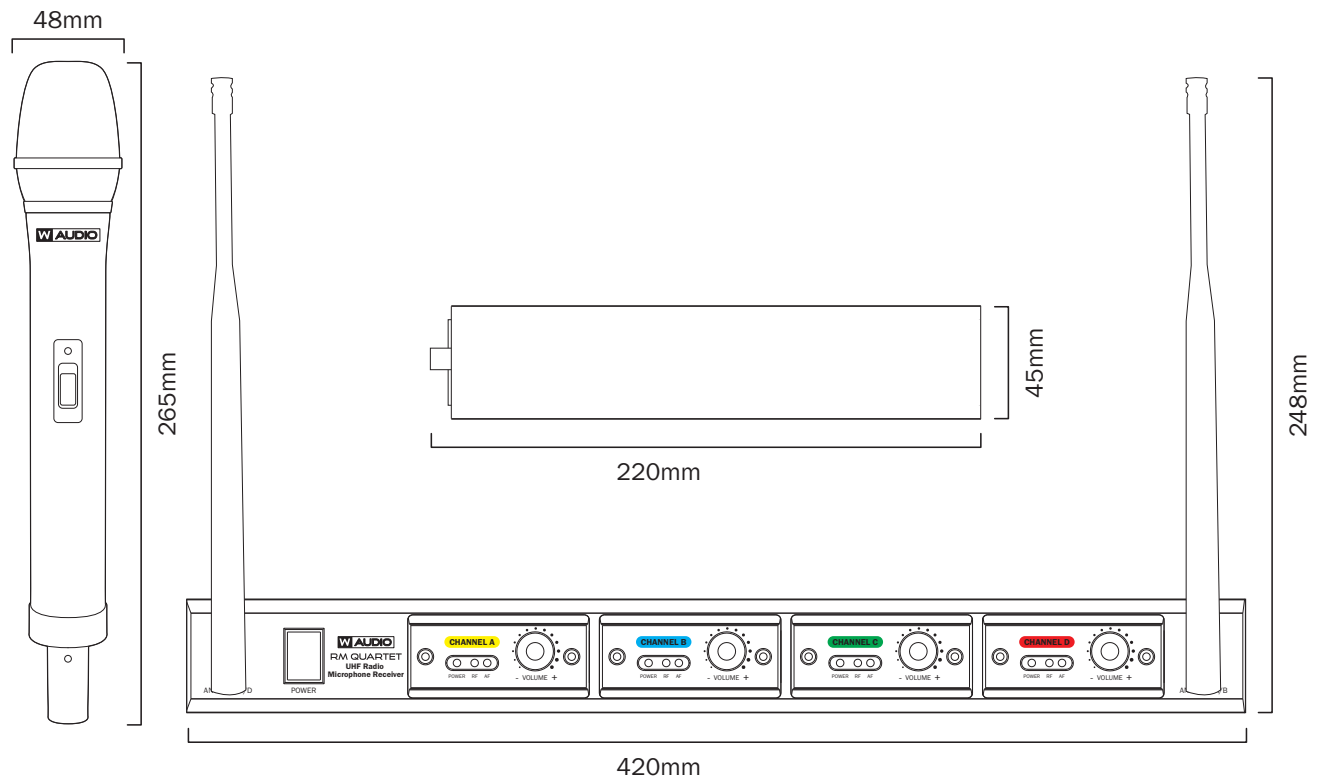

RM Quartet receiver (front):

1. Antenna socket (channels C & D)
2. Power switch
3. Channel A power Indicator
4. Channel A radio frequency indicator
5. Channel A signal level indicator
6. Channel A volume control
7. Channel B volume control
8. Channel C volume control
9. Channel D volume control
10. Antenna socket (channels A & B)

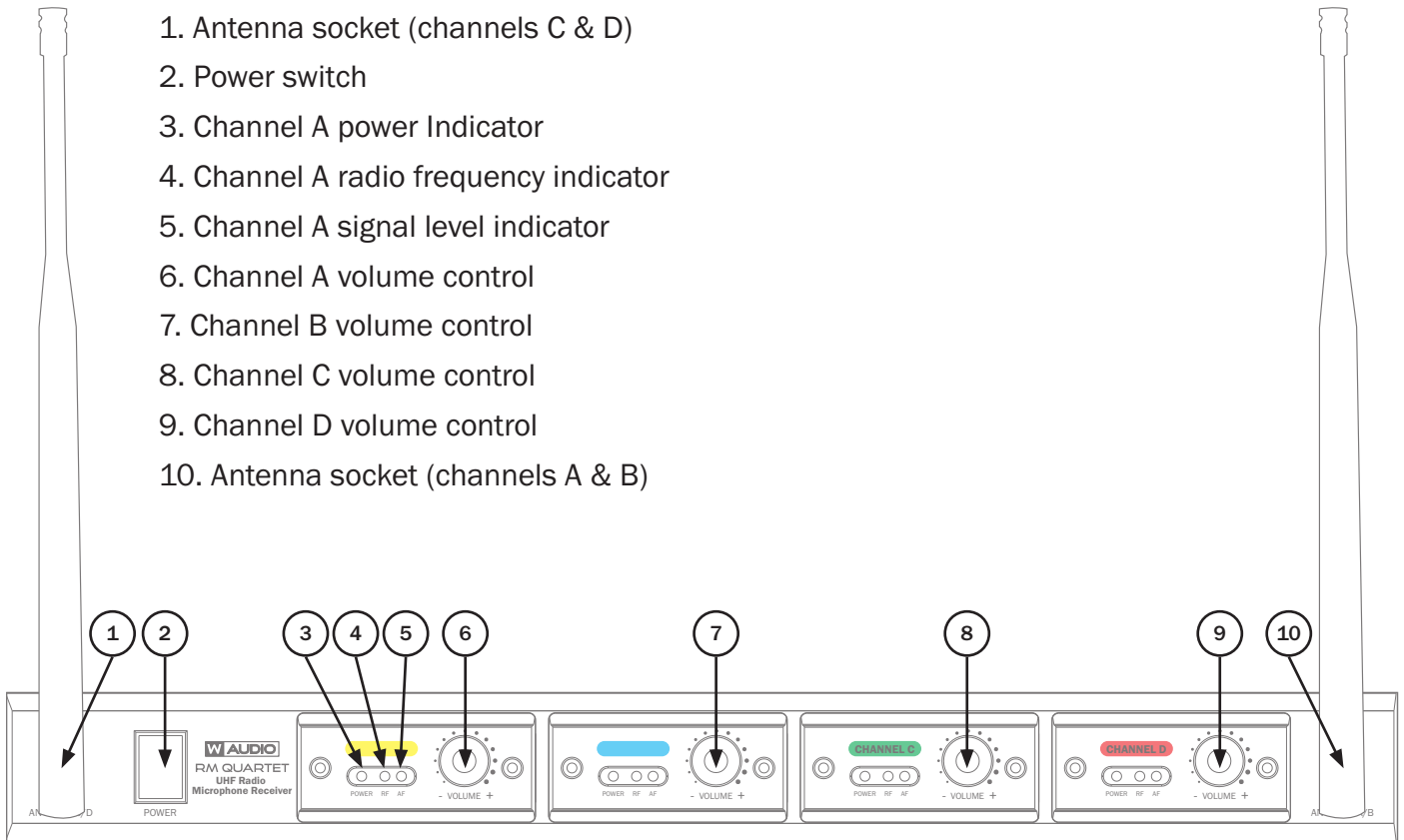

RM Quartet receiver (rear):

1. Channel D output - balanced XLR audio output
2. Channel C output - balanced XLR audio output
3. Channel B output - balanced XLR audio output
4. Channel A output - balanced XLR audio output
5. Mix output - unbalanced 1/4 inch TRS audio output
6. USB charger output (5V / 500mA)
7. DC power adaptor socket

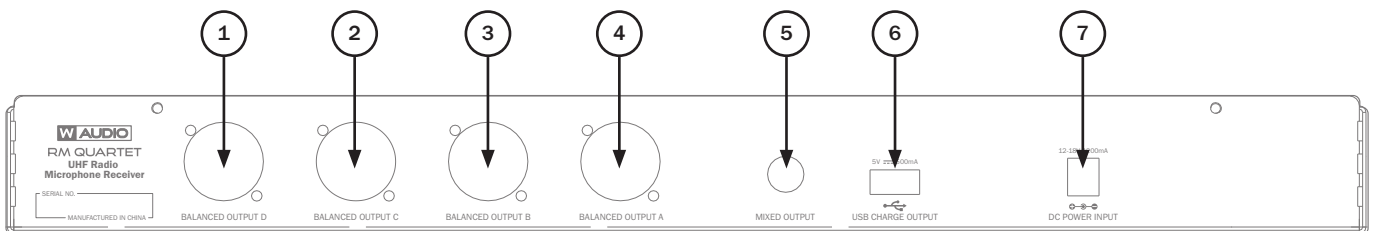

Features of the USB rechargeable microphone:

1. Grille covering microphone element
2. LED status indicator
3. Power switch (on/mute/off)
4. Battery compartment cover
5. Coloured ring indicator
6. Recharging socket

Battery compartment cover removal Unscrew the coloured ring at the base of the microphone. Remove ring (5) and slide battery compartment (4) down, then pull away.

Charging the microphones Ensure the rechargeable batteries have been correctly installed. Only use rechargeable Ni-MH batteries. Do not use standard non-rechargeable batteries as this may result in damage to the equipment. Plug the USB recharging lead (supplied) in to the USB socket on the rear of the receiver. This allows charging of two microphones at any one time. Plug the other end of the USB charging lead in to the socket on the base of the microphone.

During normal operating conditions, the battery indicator will not illuminate and will turn red when the battery runs low.

When charging, the battery indicator LED will flash continually, and illuminate permanently when fully charged. Allow the microphones to charge fully before removing the charging lead. Charge time from empty is approximately 5 hours. If microphones are not going to be used for an extended period of time please remove the batteries to prevent damage and corrosion.

Important: Do not leave the microphones plugged in to charge whilst the receiver is not powered.

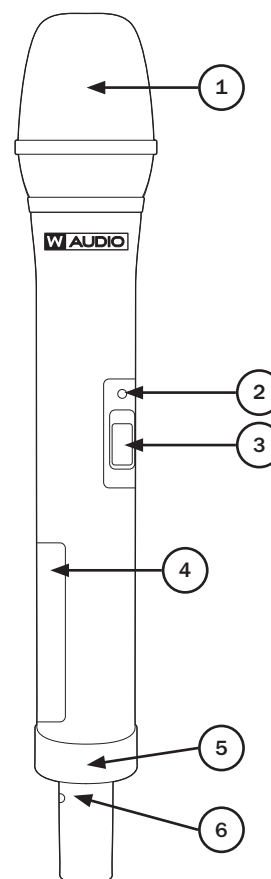

Connecting the receiver and operating system:

1. Push and turn the antenna plug in to the antenna socket on the front of the receiver, repeat for second antenna. Point both antennas upwards in a vertical position.
2. Ensure your mixer/amplifier is turned down before connecting the receiver.
3. Connect the receiver using the Mix output with the supplied 1/4 inch TRS (unbalanced) lead. This should go to the **MIC IN** on your mixer or amplifier. Control of individual microphone channel levels is via the individual channel volume controls on the front of the receiver. Alternatively, if you are using a multi-channel mixer, you can connect the receiver using the individual channel outputs using XLR (balanced) leads (not supplied).
4. Plug the DC power adaptor into the DC socket on the rear of the receiver. Plug the other end in to a suitable AC outlet.
5. Press the power switch on the front panel of the receiver to **I**. All four channel power indicator LEDs should light red.
6. Ensure all the channel volume controls are turned down to minimum. Turn your chosen microphone on using the power switch. The LED status indicator will flash red briefly to indicate it is **ON**.
7. When a microphone is turned on the status LED on the corresponding channel on the receiver will also light up. The radio frequency (RF) indicator will turn yellow to show a signal is being received from the microphone. The audio frequency (AF) indicator will turn green to show audio is being received (i.e. it will pulse with your voice as you speak in to the microphone).
8. Turn the microphone power switch to mute or **OFF** when you have finished speaking/singing in to the microphone and before you place it down on a table.

The receiver has 4 separate volume controls, one for each microphone. Use this in conjunction with the controls on your mixer/amplifier to adjust the sound level required. If the sound is distorted check the volume level controls on the receiver and the mixer/amplifier. If sound continues to be distorted move the microphone further away from your mouth and also check the battery is fully charged.

The receiver can be mounted in to a standard 19" rack mount case/rack using the supplied rack-mount brackets. Fix one of these to each side of the receiver using the supplied screws, and then fit the unit in to your rack. The microphones have a maximum effective range of around 100m, depending on the environment in which the system is being used. This can be reduced to 60m in many situations. If the sound becomes intermittent move the microphones closer to the receiver. Interference is occasionally possible when the distance between a microphone and the receiver is less than 1.5m. To achieve the best possible system performance, please keep the microphones at least 1.5m away from the receiver.

Also, for optimum reception, extend the antenna fully and orientate vertically. Reception maybe impaired by obstacles between the transmitter and receiver. High power electrical equipment can cause unwanted interference.

Troubleshooting:

Problem	Possible cause	Solution
Receiver - no sound	Power button is in the OFF position. DC power adapter is not plugged in	Turn on the power button plug in the power adapter
Receiver - no LED		
Microphone - no sound but LED indicators are lit	Mic transmitter is out of range. Mic is switched off. Mic volume it turned down. Batteries in mic are not installed properly. Receiver is not connected to an amp or mixer.	Ensure that the mic is within range. Turn on the mic switch. Turn up the mic volume on the receiver. Reinstall or use new batteries. Connect an output cable to an amp or mixer
Distorted sound or feedback	The 4 mics may be too close together. Batteries are running out of charge. Mic volume may be too high. Possible interference from another source.	Increase the distance between mics. Replace the batteries. Reduce the volume. Move the system away from other electric sources.



***Correct Disposal of this Product
(Waste Electrical & Electronic Equipment)***

**(Applicable in the European Union and other European countries
with separate collection systems)**

This marking shown on the product or its literature, indicates that it should not be disposed of with other household wastes at the end of its working life. To prevent possible harm to the environment or human health from uncontrolled waste disposal, please separate this from other types of wastes and recycle it responsibly to promote the sustainable reuse of material resources.

Household users should contact either the retailer where they purchased this product, or their local government office, for details of where and how they can take this item for environmentally safe recycling.

Business users should contact their supplier and check the terms and conditions of the purchase contract. This product should not be mixed with other commercial wastes for disposal.



