

LEDJ

Libretto Mini Bi-CCT Profile

User Manual



Order codes: LEDJ601

WARNING

FOR YOUR OWN SAFETY, PLEASE READ THIS USER MANUAL CAREFULLY BEFORE YOUR INITIAL START-UP!

- Before your initial start-up, please make sure that there is no damage caused during transportation.
- Should there be any damage, consult your dealer and do not use the equipment.
- To maintain the equipment in good working condition and to ensure safe operation, it is necessary for the user to follow the safety instructions and warning notes written in this manual.
- Please note that damages caused by user modifications to this equipment are not subject to warranty.



IMPORTANT:

The manufacturer will not accept liability for any resulting damages caused by the non-observance of this manual or any unauthorised modification to the equipment.

- Never let the power cable come into contact with other cables. Handle the power cable and all mains voltage connections with particular caution!
- Never remove warning or informative labels from the unit.
- Do not open the equipment and do not modify the unit.
- Do not connect this equipment to a dimmer pack.
- Do not switch the equipment on and off in short intervals, as this will reduce the system's life.
- Only use the equipment indoors.
- Do not expose to flammable sources, liquids or gases.
- Always disconnect the power from the mains when equipment is not in use or before cleaning! Only handle the power-cable by the plug. Never pull out the plug by pulling the power-cable.
- Make sure that the available mains supply voltage is between 100~240V AC, 50/60Hz.
- Make sure that the power cable is never crimped or damaged. Check the equipment and the power cable periodically.
- If the equipment has been exposed to drastic temperature fluctuation (e.g. after transportation), do not connect power or switch it on immediately. The arising condensation might damage the equipment. Leave the equipment switched off until it has reached room temperature.
- Never touch the fixture during operation as it may be hot.
- If the equipment is dropped or damaged, disconnect the mains power supply immediately and have a qualified engineer inspect the equipment before operating again.
- If your product fails to function correctly, stop use immediately. Pack the unit securely (preferably in the original packing material), and return it to your Pro Light dealer for service.
- Only use fuses of same type and rating.
- Repairs, servicing and power connection must only be carried out by a qualified technician. THIS UNIT CONTAINS NO USER SERVICEABLE PARTS.
- This lighting fixture is for professional use only - it is not designed for or suitable for household use. The product must be installed by a qualified technician in accordance with local territory regulations. The safety of the installation is the responsibility of the installer. The fixture presents risks of severe injury or death due to fire hazards, electric shock and falls.
- Warning! Risk Group 2 LED product according to EN 62471. Do not view the light output with optical instruments or any device that may concentrate the beam.
- WARRANTY: Two years from date of purchase.

OPERATING DETERMINATIONS

If this equipment is operated in any other way, than those described in this manual, the product may suffer damage and the warranty becomes void. Incorrect operation may lead to danger e.g: short-circuit, burns and electric shocks etc.

Do not endanger your own safety and the safety of others!

Incorrect installation or use can cause serious damage to people and/or property.

Libretto Mini Bi-CCT Profile

The Libretto Bi-CCT is a 50W COB LED Profile which combines both warm-white and cool-white within the same LED chip. Ideally suited to gallery, museum and theatres applications it operates with a manually adjustable zoom range of 14-31 degrees and projects a precise, focused hard-edge beam. Control is via both DMX and the on-board menu. Beam shaping is possible with the four-blade shutter system and both metal and glass gobos can be installed. Five metal gobos are included with the fixture.

- 1 x 50W cool white (5800K) and warm white (2800K) COB LED (CW/WW)
- Manually adjustable beam angle: 14° - 31°
- 14° - 1,786 Lux @ 2m, 31° - 1,625 Lux @ 2m
- 2kHz refresh rate
- CRI: CW - 95, WW - 96
- Beam framing shutters
- Zoom and focus adjustment
- Gobo slot
- DMX channels: 2/3 or 3 selectable
- Manual dimming mode via menu
- 0-100% dimming and variable strobe
- 4 dimming curves: Linear, square law, inverse square law and S-curve
- 4 push button menu with OLED display
- PowerCON input/output
- 5-Pin XLR input/output
- Fan cooled
- Rear positioning handle
- Includes 5 metal gobos
- Filter frame included



14° - Lux					
FULL ON	7144	1786	794	447	286
CW	8728	2182	970	546	349
WW	5624	1406	625	352	225

31° - Lux					
FULL ON	6500	1625	722	406	260
CW	7868	1967	874	492	315
WW	4964	1241	552	310	199

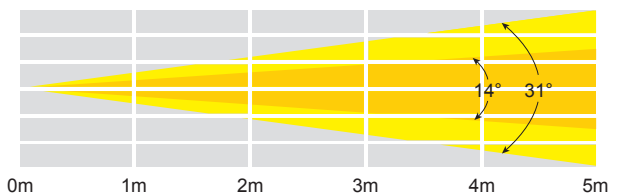

Specifications	Libretto Mini Bi-CCT
Power consumption	57W
Power supply	100-240V,50/60Hz
Fuse	T1A 250V
Dimensions	260 x 171 x 405mm
Weight	2.6kg
Order code	LEDJ601

Included gobos:



Gobo 1

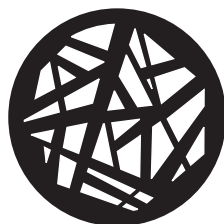

Gobo 2

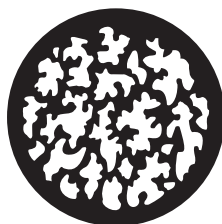

Gobo 3

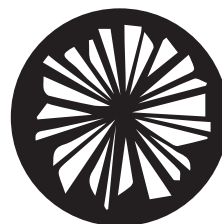

Gobo 4

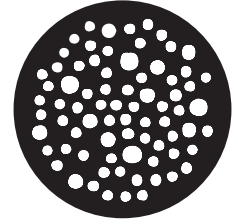

Gobo 5

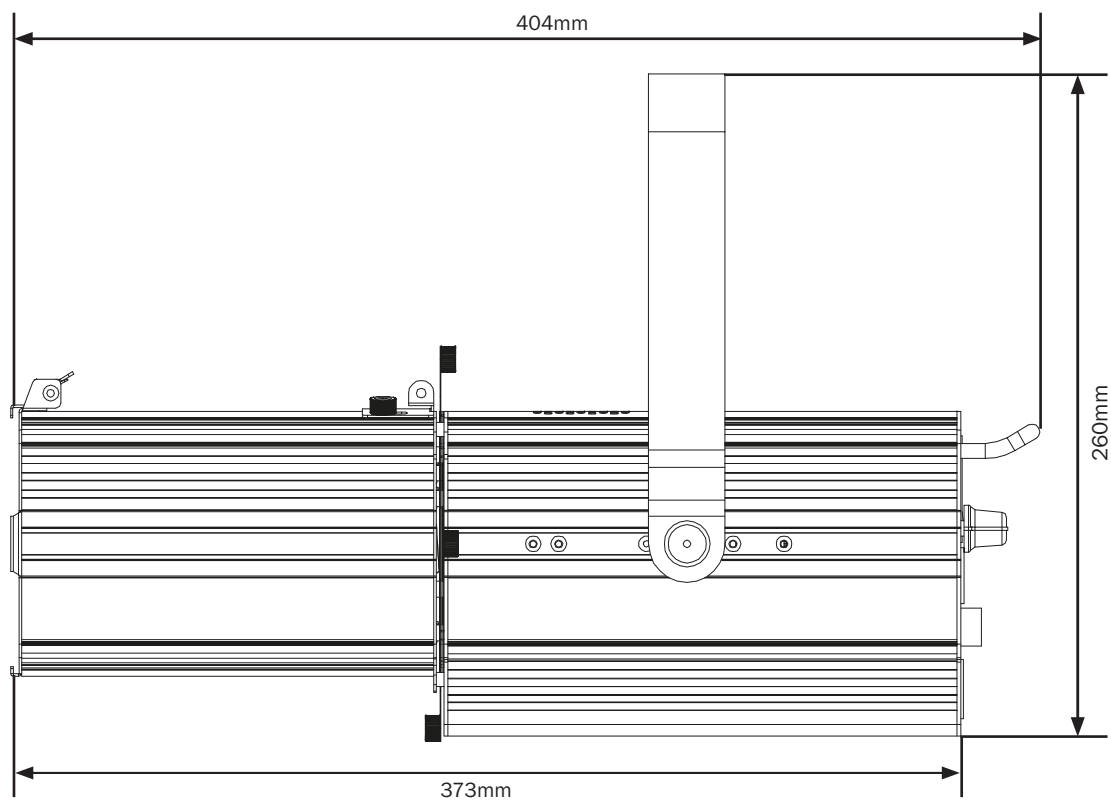
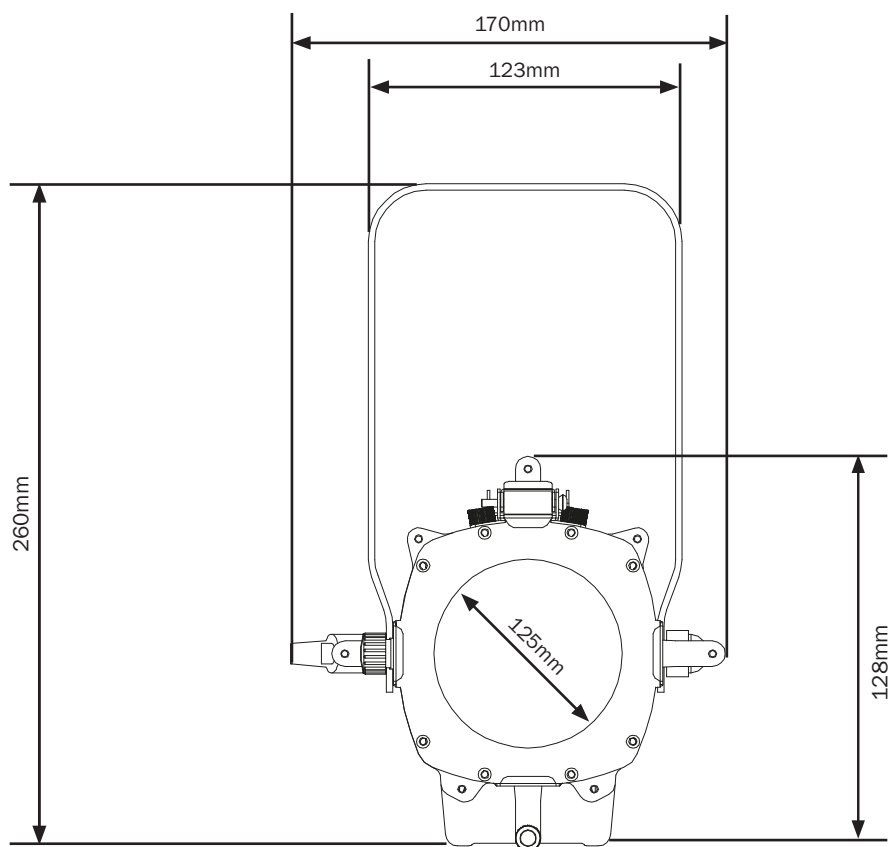

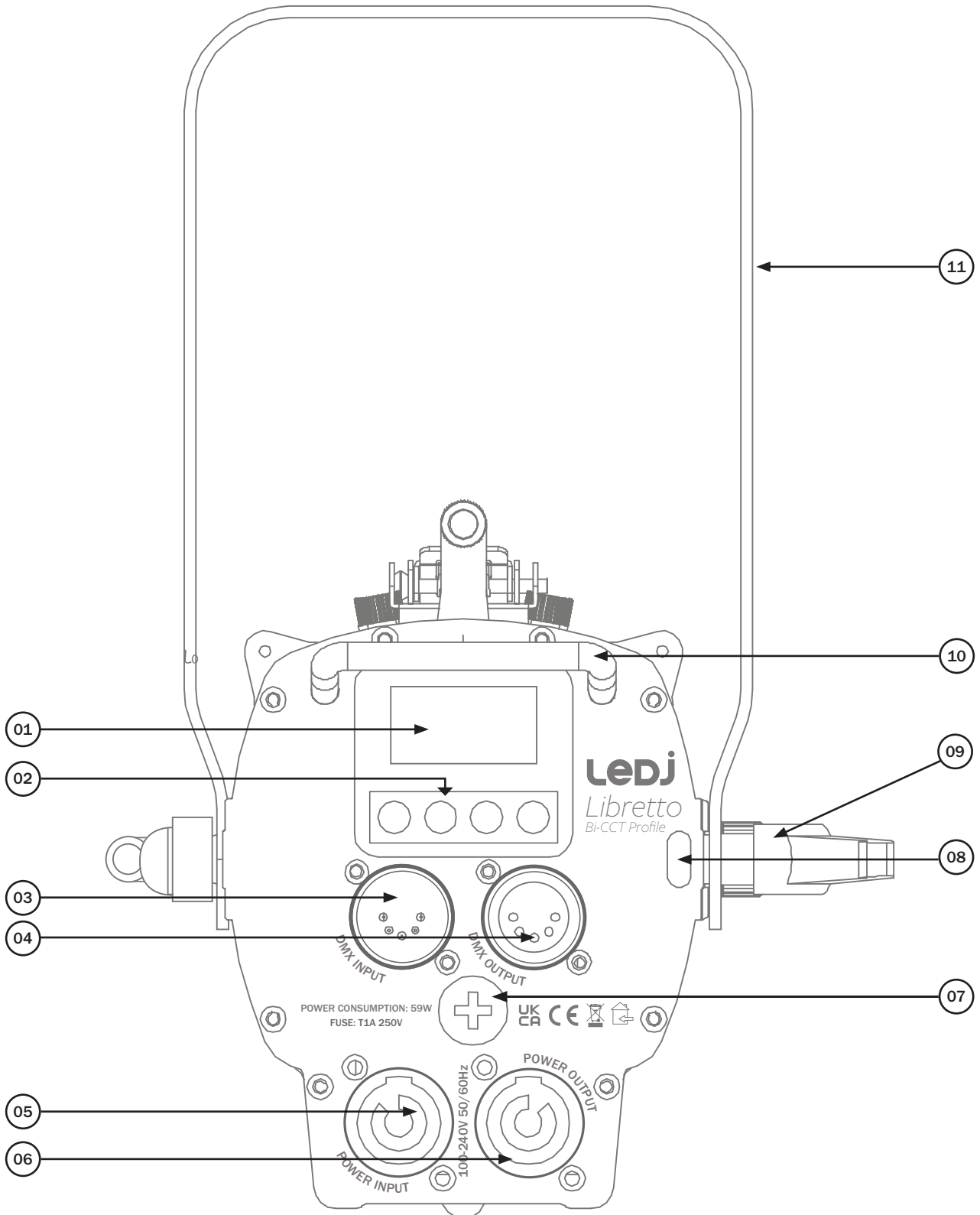

- 01 - OLED display
- 02 - Function buttons
- 03 - 5-Pin DMX input
- 04 - 5-Pin DMX output

- 05 - PowerCON input
- 06 - PowerCON output
- 07 - Fuse T1A 250V
- 08 - Safety eye

- 09 - Hanging bracket adjustment knobs
- 10 - Positioning handle
- 11 - Hanging bracket

In the box: **1 x fixture, 5 x metal gobos & 1 x power cable**

Before installing the fixture, the supporting structure (ie. truss) must be able to hold a minimum of 10 times the fixtures weight without any deformation (eg. 15kg - 150kg point load). The fixture must be secured with a secondary safety attachment when being installed (ie. an appropriate safety cable). Never stand directly below the fixture when mounting, removing, and/or servicing.

Overhead installation requires experience and qualifications to calculate working load limits, the material being used at the installation area and periodic safety inspections of the fixture and installation material. If you do not have the relevant experience and/or qualifications please do not attempt the installation yourself. The installation should be checked annually by a qualified person.

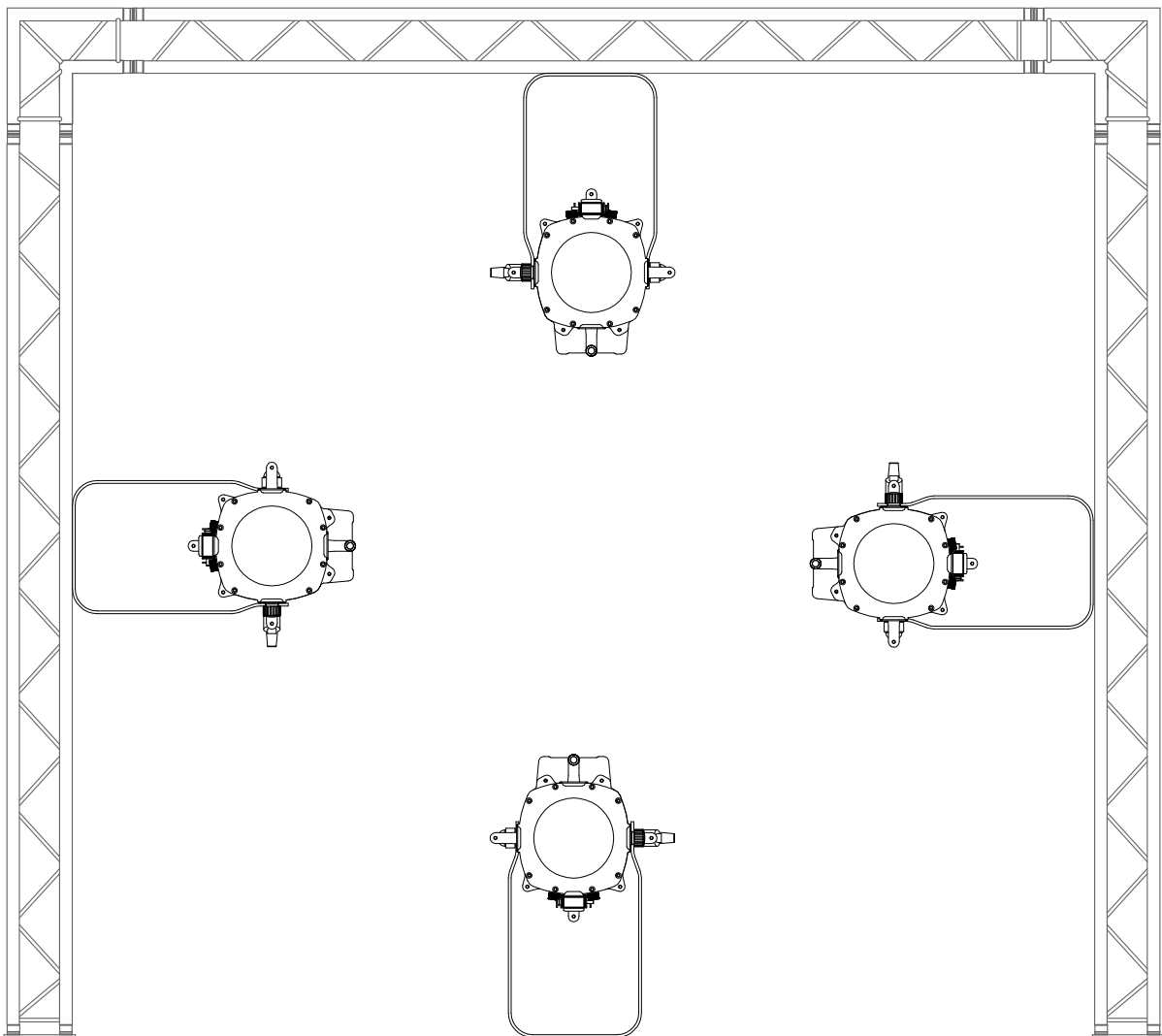

The Libretto Mini Bi-CCT Profile can be operated in a number of mounting positions as shown in the diagram above, hanging upside-down from the ceiling or truss, mounting sideways on truss or stood upright on a flat level surface. Always use a safety wire as an extra safety precaution to prevent damage/injury in the event a clamp fails (see the next page for clamp installation). Never use the carry handles for secondary attachments.

Control Panel Menu:

The OLED control panel situated on the front of the fixture allows the user to access the menu system to adjust the fixtures settings.

When the unit has been powered on the display will show “**Libretto Mini Bi-CCT Profile**”.

The fixture will then return to its home screen.

Pressing the “**MENU**” button once will take the user to the fixtures main menu. Using the “**UP**” and “**DOWN**” buttons you can then navigate between the different options in the main menu. Pressing the “**ENTER**” button on one of these options allows you to access the sub menu where you can use the “**UP**” and “**DOWN**” buttons to select option/value required. Once the option/value has been selected press the “**ENTER**” button once more to confirm the setting.

To exit out of any of the above options, press and hold the “**MENU**” button.

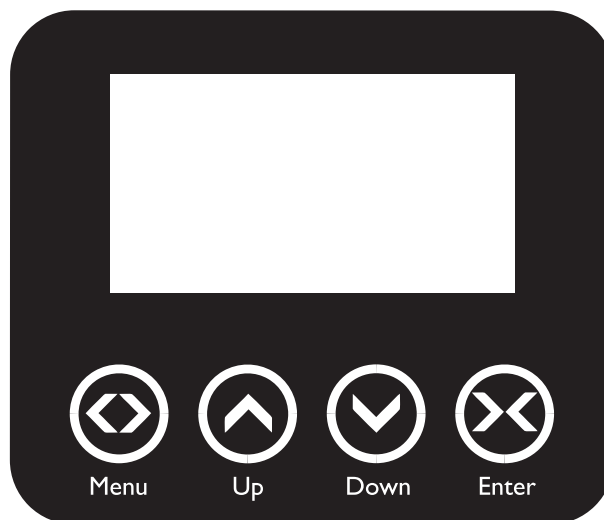

Main Menu	Sub Menu	Options/Values (Default Settings in BOLD)	Description
DMX Functions	DMX Address	1 -512	DMX Address Setting
	Mode	2 Channel	DMX Channel Setting--
		3-1 Channel	
		3-2 Channel	
	DMX Fail	Manual Mode	DMX Fail Setting
		Hold	
Blackout			
View DMX Value			View DMX Value
Fixture Settings	Dimmer Curve	Linear	Dimming Curve Setting
		Square Law	
		Inverse Squ	
		S-Curve	
Dimmer Speed	LED	Dimming Speed Setting	
	Halogen		
Manual Mode	Dimmer	0 -255	Function Mode Setting
	Shutter	0 -255	
	Warm white	0 -255	
	Cool White	0 -255	
	Colour Macros	0 -255	
Display Settings	Display Inverse	No	Display Inverse Setting
		Yes	
	Backlight Auto Off	No	Backlight Setting
		Yes	
Display Contrast	0-30 (15)	Display Brightness Setting	
Fixture Test	Auto Test		Auto Test
Fixture Information	Fixture Use Time	XXX	Fixture Run Time
	Firmware Version	CPU-A V 0.0 B 1.0	Fixture Firmware Version
Special Functions	Factory Settings	No	Default Factory Settings
		Yes	

2/3-1 channel mode:

Channel			Value	Function
2 Channel	3 Channel	Channel		
1	1	Dimmer	000-255	Dimmer (0-100%)
2	2	Colour Temp	000-255	Colour Temp (2800-6000K)
-	3	CCT Macro	000-024	No Function
			025-049	2800K
			050-074	3200K
			075-099	3600K
			100-124	4000K
			125-149	4400K
			150-174	4800K
			175-199	5200K
			200-224	5600K
			225-255	6000K

3-2 channel mode:

3 Channel	Channel	Value	Function
1	Warm	000-255	Dimmer (0-100%)
2	Cool White	000-255	Dimmer (0-100%)
3	Master Dimmer	000-255	Dimmer (0-100%)

Setting the DMX address:

The DMX mode enables the use of a universal DMX controller. Each fixture requires a “start address” from 1- 512. A fixture requiring one or more channels for control begins to read the data on the channel indicated by the start address. For example, a fixture that occupies or uses 7 channels of DMX and was addressed to start on DMX channel 100, would read data from channels: 100, 101, 102, 103, 104, 105 and 106. Choose a start address so that the channels used do not overlap. E.g. the next unit in the chain starts at 107.

DMX 512:

DMX (Digital Multiplex) is a universal protocol used as a form of communication between intelligent fixtures and controllers. A DMX controller sends DMX data instructions from the controller to the fixture. DMX data is sent as serial data that travels from fixture to fixture via the DATA “IN” and DATA “OUT” XLR terminals located on all DMX fixtures (most controllers only have a data “out” terminal).

DMX linking:

DMX is a language allowing all makes and models of different manufactures to be linked together and operate from a single controller, as long as all fixtures and the controller are DMX compliant. To ensure proper DMX data transmission, when using several DMX fixtures try to use the shortest cable path possible. The order in which fixtures are connected in a DMX line does not influence the DMX addressing. For example; a fixture assigned to a DMX address of 1 may be placed anywhere in a DMX line, at the beginning, at the end, or anywhere in the middle. When a fixture is assigned a DMX address of 1, the DMX controller knows to send DATA assigned to address 1 to that unit, no matter where it is located in the DMX chain.

DATA cable (DMX cable) requirements (for DMX operation):

This fixture can be controlled via DMX-512 protocol. The DMX address is set on the back of the unit. Your unit requires either a standard 3-pin or 5-pin XLR connector for data input/output, see images below.

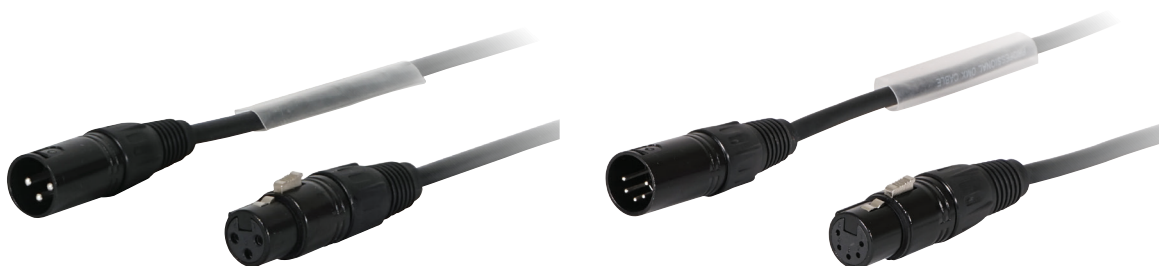

Further DMX cables can be purchased from all good sound and lighting suppliers or Prolight Concepts dealers.

Please quote:	3-Pin:	CABL10 - 2m	CABL11 - 5m	CABL12 - 10m
	5-Pin:	CABL185 - 2m	CABL187 - 5m	CABL188 - 10m

Also remember that DMX cable must be daisy chained and cannot be split.

Notice:

Be sure to follow the diagrams below when making your own cables. Do not connect the cables shield conductor to the ground lug or allow the shield conductor to come in contact with the XLRs outer casing. Grounding the shield could cause a short circuit and erratic behaviour.

Pin Configuration	
3-Pin	5-Pin
	Pin 1 - Ground
	Pin 2 - Negative
	Pin 3 - Positive
-	Pin 4 - N/C
-	Pin 5 - N/C

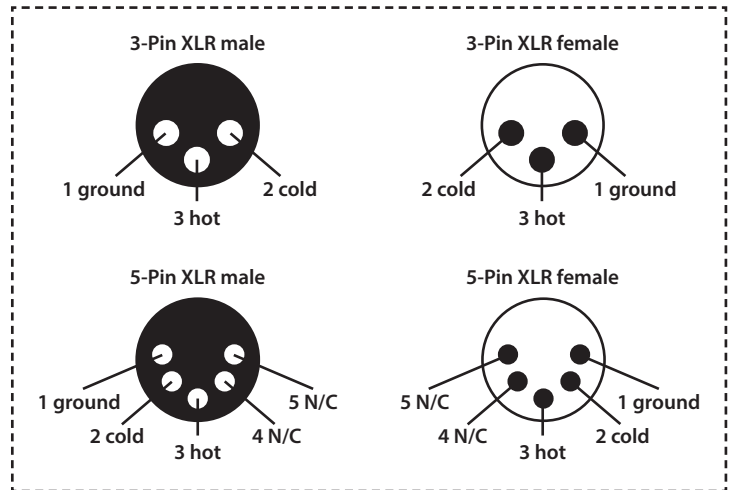
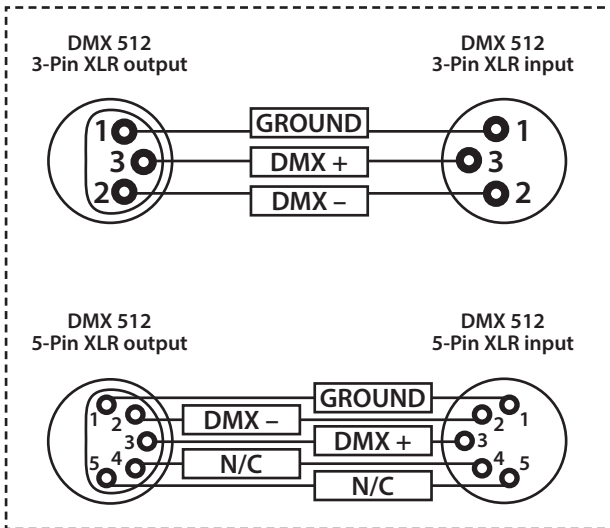

Line termination:

When longer runs of cable are used, you may need to use a terminator on the last unit to avoid erratic behaviour.

Using a cable terminator will decrease the possibilities of erratic behaviour.

(3-pin - Order ref: CABL90,
5-pin - Order ref: CABL89)

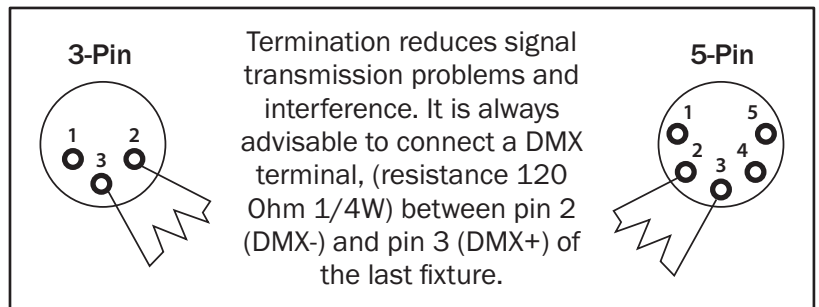

5-pin XLR DMX connectors:

Some manufactures use 5-pin XLR connectors for data transmission in place of 3-pin. 5-pin XLR fixtures may be implemented in a 3-pin XLR DMX line. When inserting standard 5-pin XLR connectors in to a 3-pin line a cable adaptor must be used. The diagram below details the correct cable conversion.

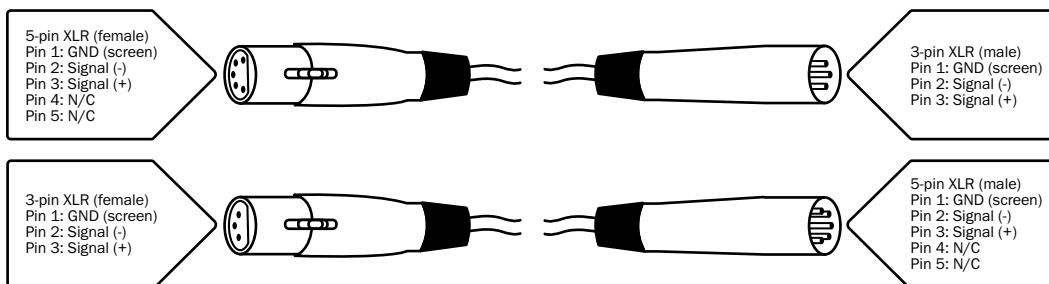

Power linking:

This fixture provides power linking via the power output on the rear allowing multiple units to be connected together. The maximum number of fixtures that can be connected is 24 fixtures @ 240V or 12 fixtures @ 120V (including the first fixture). After the maximum number of fixtures are connected a new power run will need to be started.

Please note: Caution should be used when power linking other fixtures to the Libretto Mini Bi-CCT Profile as the power consumption of other fixtures will vary. Fixtures fitted with lamps often require 2/3 times more current on startup, these may require their own power source.

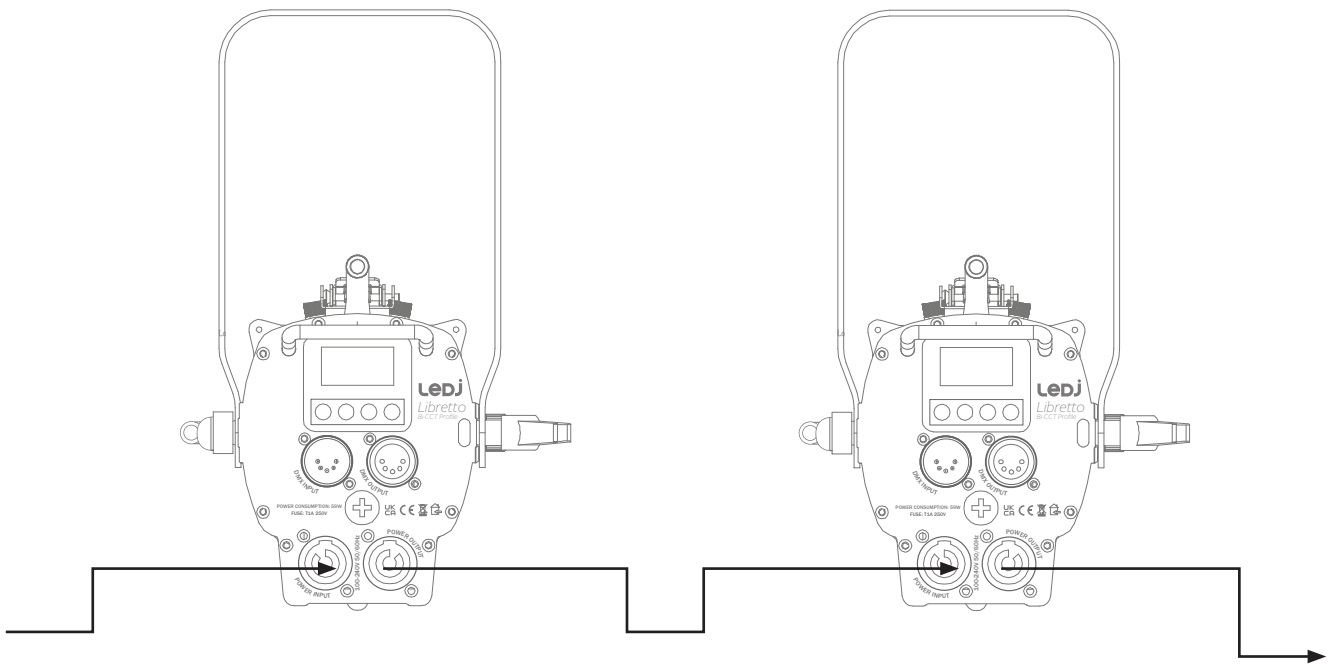



***Correct Disposal of this Product
(Waste Electrical & Electronic Equipment)***

**(Applicable in the European Union and other European countries
with separate collection systems)**

This marking shown on the product or its literature, indicates that it should not be disposed with other household wastes at the end of its working life. To prevent possible harm to the environment or human health from uncontrolled waste disposal, please separate this from other types of wastes and recycle it responsibly to promote the sustainable reuse of material resources.

Household users should contact either the retailer where they purchased this product, or their local government office, for details of where and how they can take this item for environmentally safe recycling.

Business users should contact their supplier and check the terms and conditions of the purchase contract. This product should not be mixed with other commercial wastes for disposal.



LEDj