

# LEDJ

## **Spectra Spot 40 WW** **Exterior Fixture**

User Manual



Order code: LEDJ553

**WARNING****FOR YOUR OWN SAFETY, PLEASE READ THIS USER MANUAL CAREFULLY BEFORE YOUR INITIAL START-UP!**

- Before your initial start-up, please make sure that there is no damage caused during transportation.
- Should there be any damage, consult your dealer and do not use the equipment.
- To maintain the equipment in good working condition and to ensure safe operation, it is necessary for the user to follow the safety instructions and warning notes written in this manual.
- Please note that damages caused by user modifications to this equipment are not subject to warranty.

**IMPORTANT:**

**The manufacturer will not accept liability for any resulting damages caused by the non-observance of this manual or any unauthorised modification to the equipment.**

- Never let the power cable come into contact with other cables. Handle the power cable and all mains voltage connections with particular caution!
- Never remove warning or informative labels from the unit.
- Do not open the equipment and do not modify the unit.
- Do not connect this equipment to a dimmer pack.
- Do not switch the equipment on and off in short intervals, as this will reduce the system's life.
- Do not expose to flammable sources, liquids or gases.
- Always disconnect the power from the mains when equipment is not in use or before cleaning! Only handle the power-cable by the plug. Never pull out the plug by pulling the power-cable.
- Make sure that the available mains supply voltage is between 100~240V AC, 50/60Hz.
- Make sure that the power cable is never crimped or damaged. Check the equipment and the power cable periodically.
- If the equipment is dropped or damaged, disconnect the mains power supply immediately and have a qualified engineer inspect the equipment before operating again.
- If your product fails to function correctly, stop use immediately. Pack the unit securely (preferably in the original packing material), and return it to your Pro Light dealer for service.
- Only use fuses of same type and rating.
- Repairs, servicing and power connection must only be carried out by a qualified technician. **THIS UNIT CONTAINS NO USER SERVICEABLE PARTS.**
- This lighting fixture is for professional use only - it is not designed for or suitable for household use. The product must be installed by a qualified technician in accordance with local territory regulations. The safety of the installation is the responsibility of the installer. The fixture presents risks of severe injury or death due to fire hazards, electric shock and falls.
- Warning! Risk Group 2 LED product according to EN 62471. Do not view the light output with optical instruments or any device that may concentrate the beam.
- **WARRANTY:** One year from date of purchase.

**OPERATING DETERMINATIONS**

If this equipment is operated in any other way, than those described in this manual, the product may suffer damage and the warranty becomes void. Incorrect operation may lead to danger e.g: short-circuit, burns and electric shocks etc.

Do not endanger your own safety and the safety of others!

Incorrect installation or use can cause serious damage to people and/or property.

### PLEASE READ THE BELOW CAREFULLY BEFORE USING THE FIXTURE IN OUTDOOR/EXTREME ENVIRONMENTS



#### IP Rating:

The IP (International Protection) rating classifies and rates the degree of protection provided against intrusion of foreign objects such as dust and water into housings and electrical enclosures.

The rating consists of the letters IP followed by two digits (i.e. IP65) where the numbers define the level of protection. The first digit (solids) stands for the level of protection the enclosure provides against solid bodies, whilst the second digit (liquids) stands for the degree of protection of the equipment inside the enclosure against water.

An IP65 rated fixture is one which has been designed and tested to protect from all ingress of dust (6) and water projected by low pressure jets (6.3mm) from any angle (5).



#### Marine/Coastal Installations:

Although this fixture has an IP rating it is NOT suitable for installation in a coastal/marine environment. Installing this fixture in a coastal/marine environment could cause corrosion and excessive wear to the internal and/or external components. Any damages, faults or performance issues resulting from the installation in one of the environments listed above will void the manufacturers warranty and will NOT be subject to any warranty claims, parts or repairs.



#### IMPORTANT INFORMATION!

If this fixture is installed in extreme outdoor and/or wet conditions, it **MUST** be powered ON and operated for a minimum of 30 minutes every 1-2 weeks. Excessive usage in extreme outdoor and/or wet conditions without a consistent usage cycle as described above can lead to component damage and/or a reduced fixture lifetime. Any damage to the fixture found to be a direct result of not following the above guidelines will void the manufacturers warranty and will NOT be subject to any warranty claims, parts or repairs.

Please **ENSURE** all connections are sealed with the rubber caps if provided and the correct cables are used and connected correctly to prevent dust and/or water ingress, condensation and/or corrosion.

### Spectra Spot 40 WW



The Spectra Spot 40 is an IP rated LED pinspot, powered by a punchy 40W LED. The Spectra Spot features a tight 4.5° beam angle natively, an additional two frost lenses are also supplied expanding its versatility (10° and 25°). Super smooth dimming paired with 4 selectable dimming curves and 14 preset refresh rates further add to the abundance of features this compact fixture boasts. 4 DMX modes are included along with RDM, built-in programs and primary/secondary. The compact fixture also has IR capabilities, and its 360° rotatable snoot provides an anti-glare shield whilst the convection cooled housing ensures noise free operation.

- 1 x 40W warm-white LED (2,700K)
- Beam angle: 4.5° native, 10° and 25° frost lenses supplied
- 4.5° - 20,058 Lux @ 2m (full on)
- 10° - 12,021 Lux @ 2m (full on)
- 25° - 1,049 Lux @ 2m (full on)
- CRI: >90
- Refresh rate: 14 selectable presets between 900Hz-25kHz
- DMX channels: 1 or 3 selectable
- RDM (Remote Device Management)
- Manual and master/slave modes
- 0 - 100% dimming
- 4 dimming curves: Linear, square law, inverse square law and S-curve
- Variable strobe
- 4 button menu with OLED display
- Hydralock power input/output trailing connections
- Hydralock DMX input/output trailing connections
- Convection cooled
- 360° rotatable snoot
- Optional IR remote (LEDJ90E)



Specifications	Spectra Spot 40 WW
Power consumption	44W
Power supply	100~240V, 50/60Hz
Fuse	F1A 250V
IP rating	IP65
Dimensions (H x W x D)	152 x 162 x 177mm
Weight	2.1kg
Order code	LEDJ554

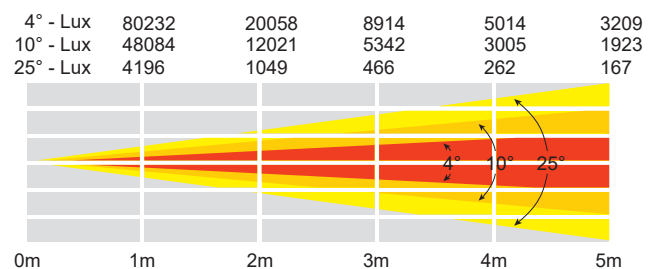

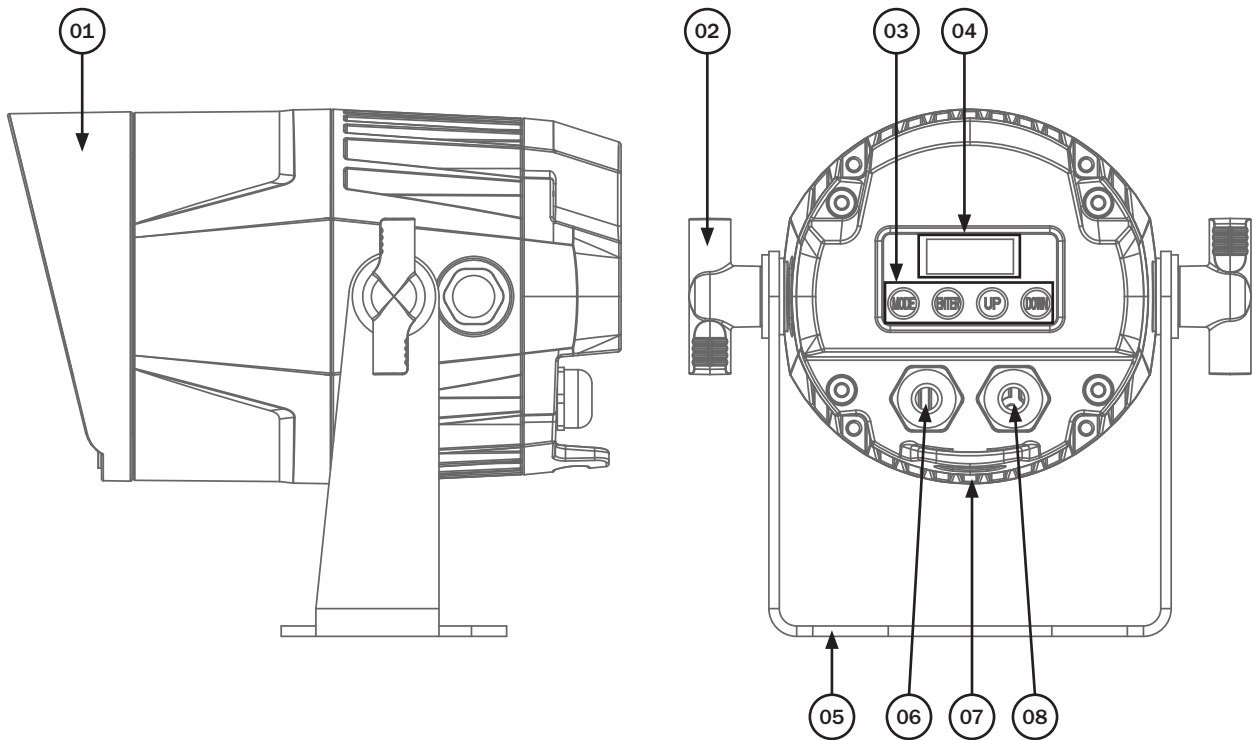
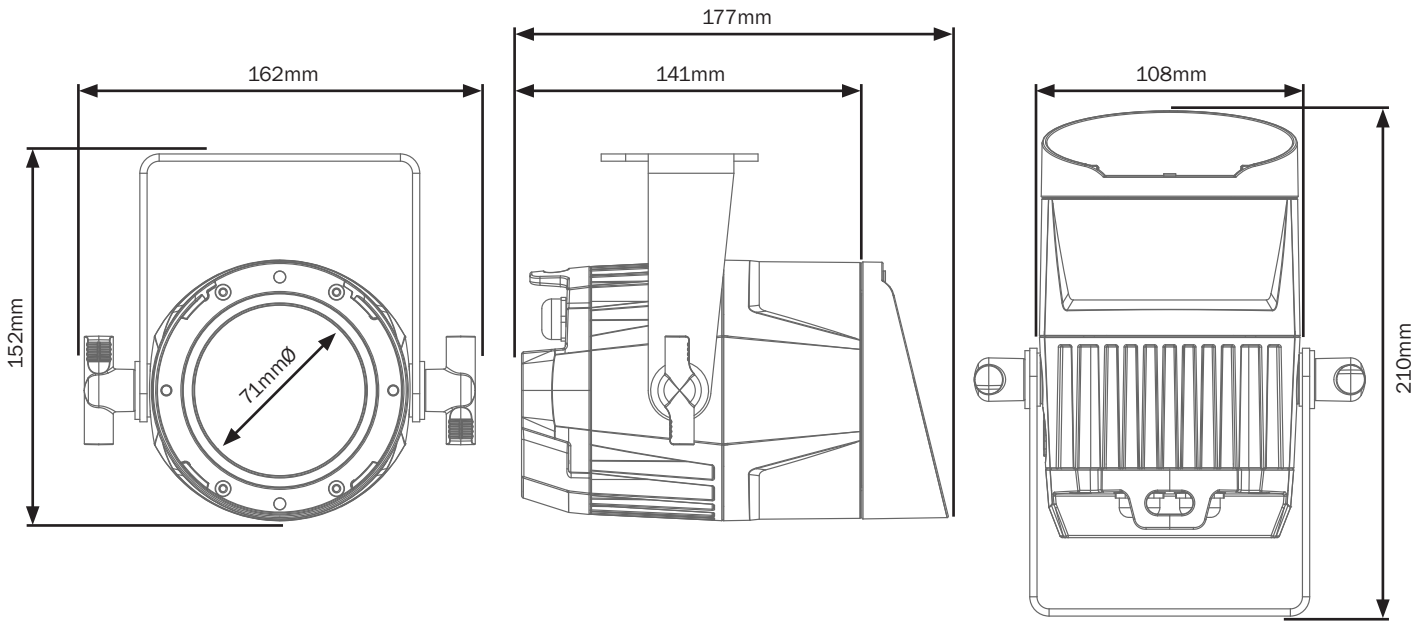

01 - 360° rotatable snout  
 02 - Bracket tightening knobs  
 03 - OLED display  
 04 - Function buttons

05 - Bracket  
 06 - Hydralock power input/output  
 07 - Safety eye  
 08 - Hydralock DMX input/output

In the box:  
**1 x fixture,**  
**2 x frost filters**  
**1 x hydralock DMX cable**  
**2 x install bolts**  
**& 1 x power cable**

Before installing the fixture, the supporting structure (ie. truss) must be able to hold a minimum of 10 times the fixtures weight without any deformation (eg. 15kg - 150kg point load). The fixture must be secured with a secondary safety attachment when being installed (ie. an appropriate safety cable). Never stand directly below the fixture when mounting, removing, and/or servicing.

Overhead installation requires experience and qualifications to calculate working load limits, the material being used at the installation area and periodic safety inspections of the fixture and installation material. If you do not have the relevant experience and/or qualifications please do not attempt the installation yourself. The installation should be checked annually by a qualified person.

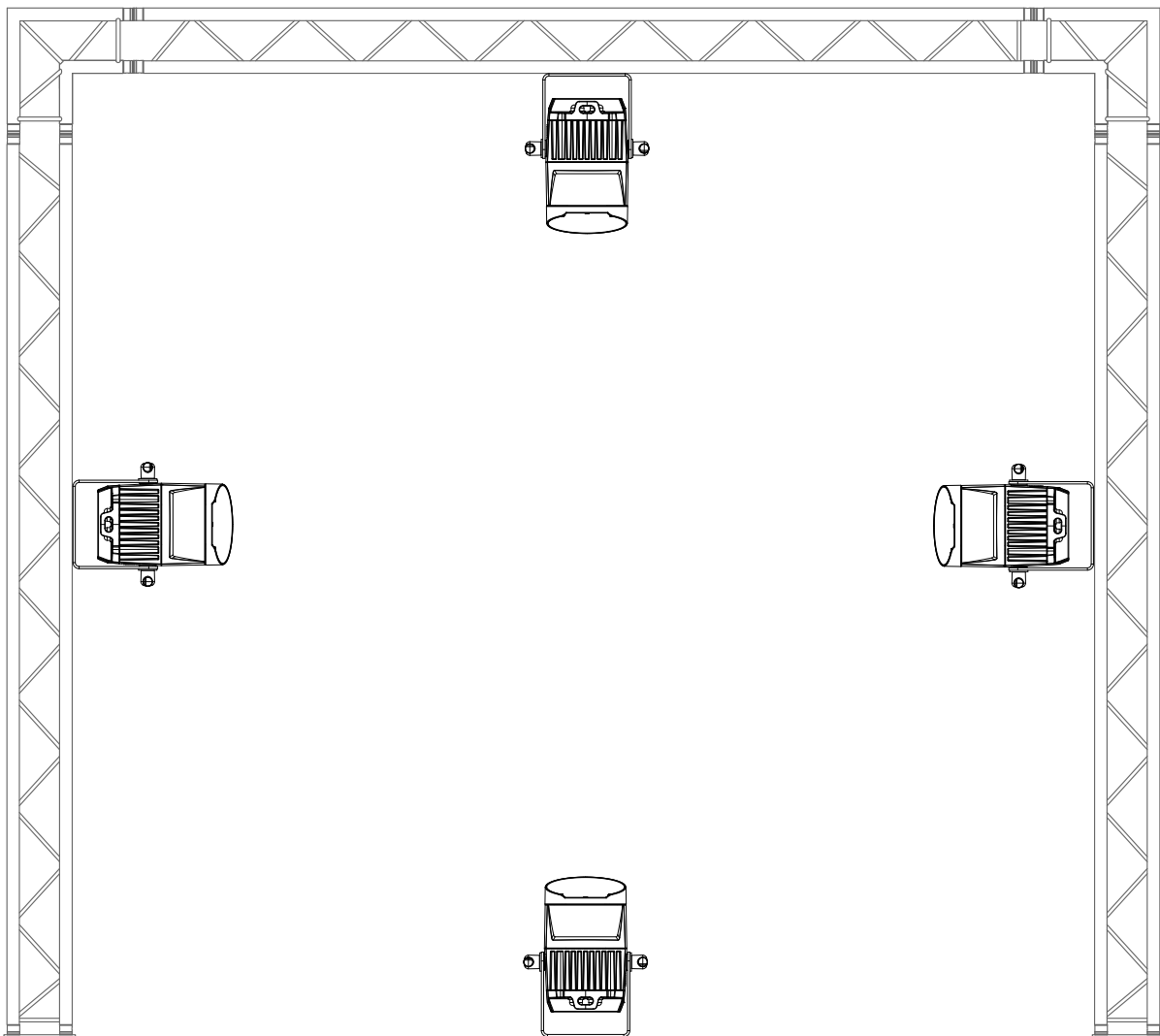

The Spectra Spot 40 can be operated in a number of mounting positions as shown in the diagram above, hanging upside-down from the ceiling or truss, mounting sideways on truss or stood upright on a flat level surface. Always use a safety wire as an extra safety precaution to prevent damage/injury in the event a clamp fails (see the next page for clamp installation). Never use the carry handles for secondary attachments.

### Installation:

1. Fasten the clamp to the fixtures bracket with a bolt and lock nut through one of the mounting holes.
2. Mount the fixture onto your truss system via the clamp and tighten to ensure secure.
3. Pull the safety cable through the fixture bracket and around the truss.

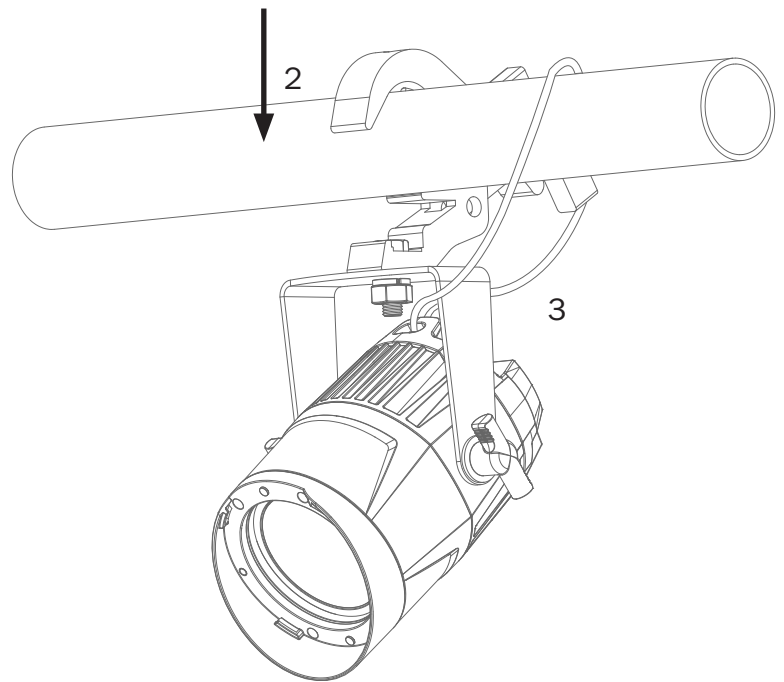
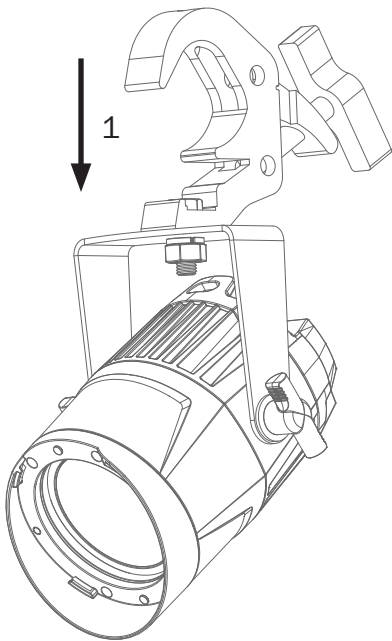
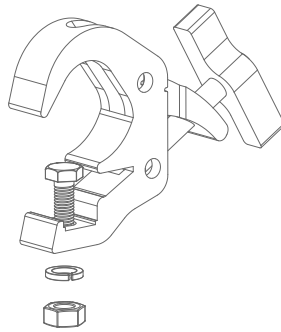

**IMPORTANT! PLEASE NOTE:** The OLED display for this fixture has a menu locking function where after 30 seconds of inactivity it will lock. To unlock the menu press and hold the “**MODE**” button for 3 seconds.

Main Menu	Sub Menu	Options/Values	Description
Start-up display screen		Software Update Please wait... LEDJ Spectra Spot 40 WW Vx.xx	Fixture Information
DMX MODE ADDR		<b>001-512</b>	DMX Address Setting
CHANNEL		CH 01 (1 channel mode)	DMX Channel Modes
		<b>CH 03 (4 channel mode)</b>	
SLAVE MODE			Slave Mode
STATIC	Dim: Str:	00-99	Manual Mode
IR. REMOTE		<b>ON</b>	IR remote setting
		OFF	
DIMMER CURVE		<b>LINEAR</b>	Dimming Curve Setting
		SQUARE LAW	
		INV. SQUARE LAW	
		S-CURVE	
REFRESH RATE		900Hz	Refresh rate setting
		1000Hz	
		1100Hz	
		<b>1200Hz</b>	
		1300Hz	
		1400Hz	
		1500Hz	
		2500Hz	
		4000Hz	
		5000Hz	
		10KHz	
		15KHz	
		20KHz	
		25KHz	
DISPLAYBACKLIGHT		10S	Display Backlight Time Setting
		20S	
		<b>30S</b>	
		60S	
		ON	
LOCKING		<b>ON</b>	Display Lock Setting (Press MODE 3s to unlock the screen)
		OFF	



### 1 channel mode:

Channel	Value	Function
1	000-255	Master dimmer (0-100%)

### 3 channel mode:

Channel	Value	Function
1	000-255	Master dimmer (0-100%)
2	000	No function
	001-255	Strobe (slow-fast)
3	<b>Dimmer Curves</b>	
	000-035	No function
	036-045	Dimmer curve set on unit
	046-055	Linear
	056-065	Square Law
	066-075	Inverse Square Law
	076-085	S-Curve
	<b>Refresh Rates</b>	
	086-115	No function
	116-125	900Hz
	126-135	1000Hz
	136-145	1100Hz
	146-155	1200Hz
	156-165	1300Hz
	166-175	1400Hz
	176-185	1500Hz
	186-195	2500Hz
	196-205	4000Hz
	206-215	5000Hz
	216-225	10kHz
	226-235	15kHz
	236-245	20kHz
	246-255	25kHz

### Setting the DMX address:

The DMX mode enables the use of a universal DMX controller. Each fixture requires a “start address” from 1- 512. A fixture requiring one or more channels for control begins to read the data on the channel indicated by the start address. For example, a fixture that occupies or uses 7 channels of DMX and was addressed to start on DMX channel 100, would read data from channels: 100,101,102,103,104,105 and 106. Choose a start address so that the channels used do not overlap. E.g. the next unit in the chain starts at 107.

### DMX 512:

DMX (Digital Multiplex) is a universal protocol used as a form of communication between intelligent fixtures and controllers. A DMX controller sends DMX data instructions from the controller to the fixture. DMX data is sent as serial data that travels from fixture to fixture via the DATA “IN” and DATA “OUT” XLR terminals located on all DMX fixtures (most controllers only have a data “out” terminal).

### DMX linking:

DMX is a language allowing all makes and models of different manufactures to be linked together and operate from a single controller, as long as all fixtures and the controller are DMX compliant. To ensure proper DMX data transmission, when using several DMX fixtures try to use the shortest cable path possible. The order in which fixtures are connected in a DMX line does not influence the DMX addressing. For example; a fixture assigned to a DMX address of 1 may be placed anywhere in a DMX line, at the beginning, at the end, or anywhere in the middle. When a fixture is assigned a DMX address of 1, the DMX controller knows to send DATA assigned to address 1 to that unit, no matter where it is located in the DMX chain.

**Also remember that DMX cable must be daisy chained and cannot be split.**

### DATA cable (DMX cable) requirements (for DMX operation):

This fixture can be controlled via DMX-512 protocol. The DMX address is set on the back of the unit.

Further DMX cables can be purchased from all good sound and lighting suppliers or Prolight Concepts dealers. Please quote:

LEDJ 1m XLR - Hydralock DMX cable	LEDJ 1m Hydralock DMX cable	LEDJ 2m Hydralock DMX cable	LEDJ 5m Hydralock DMX cable	LEDJ 10m Hydralock DMX cable
				
Order code: LEDJ91	Order code: LEDJ141	Order code: LEDJ142	Order code: LEDJ143	Order code: LEDJ144

LEDJ 1m Hydralock Power cable	LEDJ 2m Hydralock Power cable	LEDJ 5m Hydralock Power cable	LEDJ 10m Hydralock Power cable	LEDJ Hydralock End Cap Set
				
Order code: LEDJ146	Order code: LEDJ147	Order code: LEDJ148	Order code: LEDJ149	Order code: LEDJ93

**Notice:**

Be sure to follow the diagrams below when making your own cables. Do not connect the cables shield conductor to the ground lug or allow the shield conductor to come in contact with the XLRs outer casing. Grounding the shield could cause a short circuit and erratic behaviour.

Pin Configuration	
3-Pin	5-Pin
	Pin 1 - Ground
	Pin 2 - Negative
	Pin 3 - Positive
-	Pin 4 - N/C
-	Pin 5 - N/C

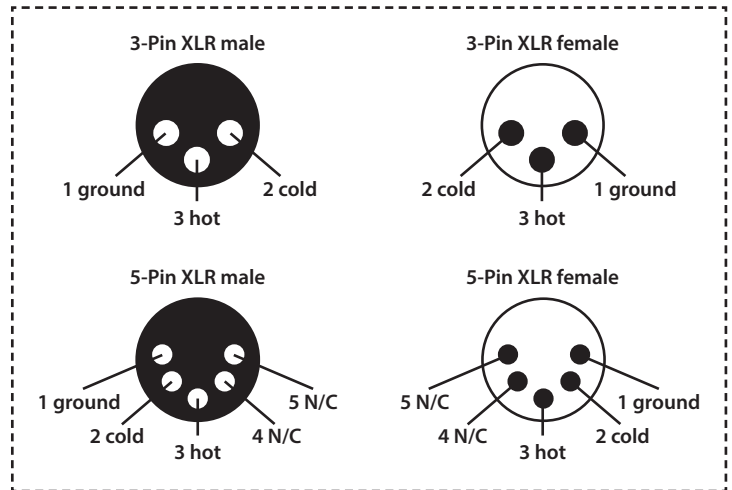
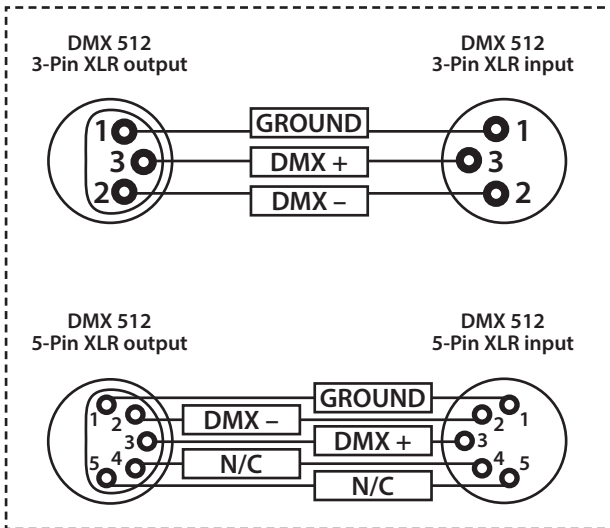

**Line termination:**

When longer runs of cable are used, you may need to use a terminator on the last unit to avoid erratic behaviour.

**Using a cable terminator will decrease the possibilities of erratic behaviour.**

(3-pin - Order ref: CABL90,  
5-pin - Order ref: CABL89)

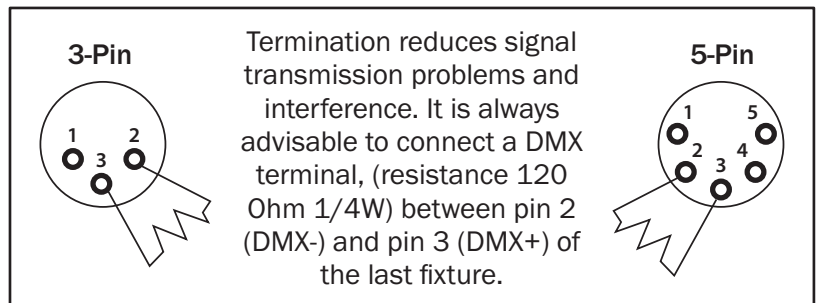

**5-pin XLR DMX connectors:**

Some manufactures use 5-pin XLR connectors for data transmission in place of 3-pin. 5-pin XLR fixtures may be implemented in a 3-pin XLR DMX line. When inserting standard 5-pin XLR connectors in to a 3-pin line a cable adaptor must be used. The diagram below details the correct cable conversion.

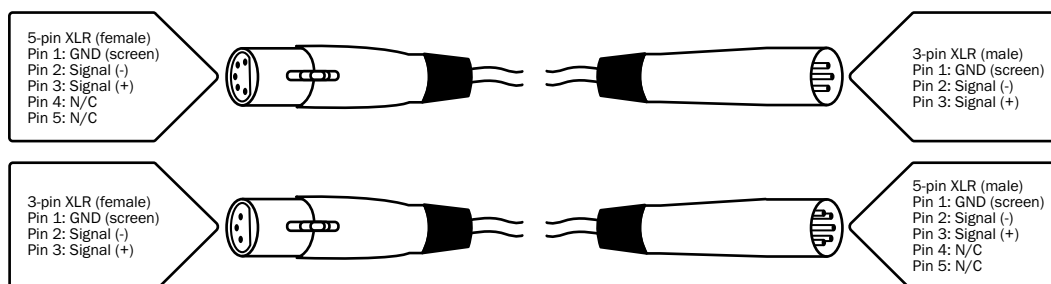

### Power linking:

This fixture provides power linking via the power output on the rear allowing multiple units to be connected together. The maximum number of fixtures that can be connected is 30 fixtures @ 240V or 15 fixture @ 120V (including the first fixture). After the maximum number of fixtures are connected a new power run will need to be started.

Please note: Caution should be used when power linking other fixtures to the Spectra Spot 40 as the power consumption of other fixtures will vary. Fixtures fitted with lamps often require 2/3 times more current on startup, these may require their own power source.

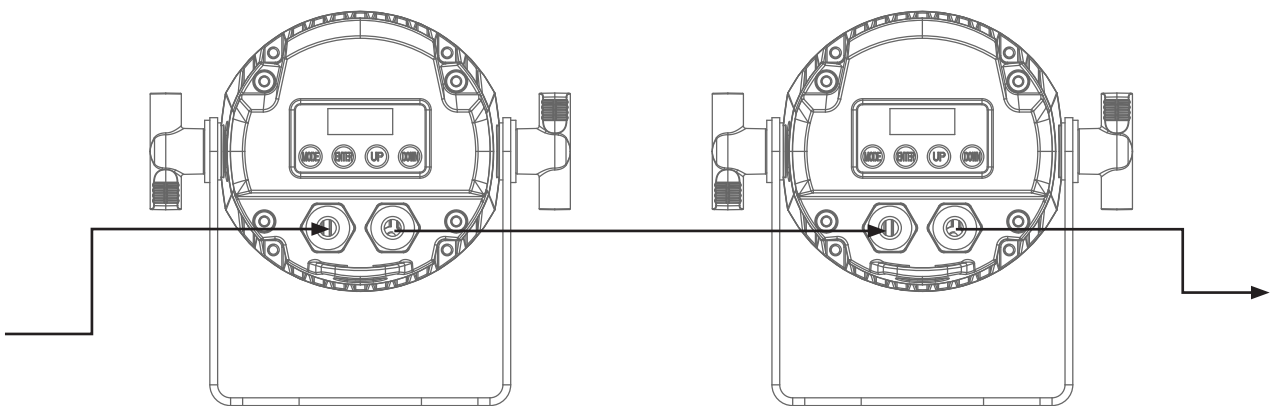



***Correct Disposal of this Product  
(Waste Electrical & Electronic Equipment)***

**(Applicable in the European Union and other European countries  
with separate collection systems)**

This marking shown on the product or its literature, indicates that it should not be disposed of with other household wastes at the end of its working life. To prevent possible harm to the environment or human health from uncontrolled waste disposal, please separate this from other types of wastes and recycle it responsibly to promote the sustainable reuse of material resources.

Household users should contact either the retailer where they purchased this product, or their local government office, for details of where and how they can take this item for environmentally safe recycling.

Business users should contact their supplier and check the terms and conditions of the purchase contract. This product should not be mixed with other commercial wastes for disposal.

