

Application

Beam style	Variable-spread, soft-edged beam
Suitable for	Theatres, TV studios, architectural and commercial applications
Specification level	Professional range
Beam angle	15°-51° (1/2 P.A.)
Typical throw distance	2 – 10m

Electrical specifications

Light source	120W LED, RGBW
Supply Volts	100/260V AC single phase
Frequency / Current	50/60Hz – 0.42A @ 230V AC or 0,9 A @ 110V AC
Power consumption	140W at full power
Cable/connection	Neutrik powercon IN and OUT
Standards Compliance	EN60598-2-17, CE marked

Mechanical specifications

Lamp House Construction	Extruded aluminium and sheet steel
Mounting & suspension	Steel stirrup 12mm centre hole + DIN mounting.
Handle	Rear
Weight/Packed weight	5,9 kg / 7,10kg
Colour frame + safety guard	Metal, 150 x 150mm, supplied

Operational specifications

Focus adjustment	Screw focus with control at rear
Beam Shaping	Using barndoor accessory
DMX channels / connection	6 or 7 ch / XLR5 connectors, IN/OUT
Colours	RGBW
Dimming	From rear panel encoder or remote, 8 or 16 bits via DMX signal
LED temperature	Built-in sensor for real time monitoring
Ambient temperature	35°C max.
Fan speed control	3 modes available: Silent/Auto/Constant
Fade curves	2 curves (linear, square)
LED Frequency	16KHz – Flicker free
LCD display	Set-up, dmx, monitor, diagnostics
RDM	Integrated
Software upload	Remote, via dmx 512 cables

Optical specifications

Optical system	120mm diameter Fresnel lens
LED array	RGBW, round-shaped, replaceable
Rated LED life	50,000 hours at 25°C, maintain 70 % original intensity
Beam colour temperature	Any, from RGBW colour mixing
CRI (Colour Rendering Index)	> 90

Accessories

Spare metal colour frame	■ 20100103 □ 20100103B □ 20100103C
Safety guard	■ 20100203 □ 20100203B □ 20100203C
4-leaf barndoor	■ 20100301 □ 20100301B □ 20100301C
Hook clamp	20100900 Safety bond 20101300
Remoto - software upload	20702072

Photometric data

Spot	* half-peak angle									
Beam dia.*	0.5	0.7	1.0	1.2	1.5	1.7	2.0	2.2	2.5	m
R	2250	1000	562.5	360	250	183.7	140.6	111.1	90	lux
G	3875	1722.2	968.8	620	430.6	316.3	242.2	191.4	155	lux
B	350	155.6	87.5	56	38.9	28.6	21.9	17.3	14	lux
W	5000	2222	1250	800	556	408	313	247	200	lux
Full	10250	4556	2563	1640	1139	837	641	506	410	lux
Distance	2	3	4	5	6	7	8	9	10	m

Flood	* half-peak angle									
Beam dia.*	2.1	3.1	4.2	5.2	6.2	7.3	8.3	9.4	10.4	m
R	450	200	112.5	72	50	36.7	28.1	22.2	18	lux
G	700	311	175	112	78	57	44	35	28	lux
B	225	100	56.3	36	25	18.4	14.1	11.1	9	lux
W	875	388.9	218.8	140	97.2	71.4	54.7	43.2	35	lux
Full	1500	667	375	240	167	122	94	74	60	lux
Distance	2	3	4	5	6	7	8	9	10	m

Cetra f100 RGBW

120W, 100/260VAC, DMX512

LED Fresnel Luminaire

part # ■ 01101200 □ 01101201 □ 01101202

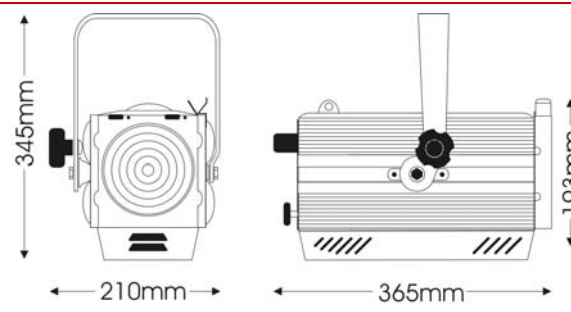

Stylish, compact and high efficiency RGBW led power source, fresnel luminaire featuring 120mm diameter Fresnel lens and DMX/RDM controllable for 16 bit dimming and infinite colour beams.

Cetra is ideal in all those applications where heat and energy saving are a concern. Its attractive design makes it the obvious choice in shop displays, art displays and architectural applications where a theatrical-type luminaire is needed.

A full range of accessories complements the range.



Luci della Ribalta srl
Via Berna 14
46042 Castel Goffredo (MN), Italy
tel: +39 0376 771777
www.ldr.it info@ldr.it

issue: ap ©2018. LDR reserves the right to alter the specification without prior notice.