

PHONE MIXER CS-8



59508-023-05

JTS®



CS-8

AUTOMATIC MICROPHONE MIXER

Important Caution	_____	01
Features	_____	01
Parts Identification	_____	02
Installation and Operation	_____	05
Internal Setup	_____	07
Specifications	_____	09

Important Caution

- Always make all connections before plugging the unit into an AC power outlet.
- Do not leave the devices in a place with high temperature or high humidity.
- Always do not handle the power cord with wet hands.
- Keep the devices away from fire and heat sources.

Features

The CS-8 Automatic Mixer provides great convenience to sound reinforcement installation with any size and any combination. Full feature design includes.

- Daisy-chain with unlimited number of the CS-8.
- Three operation modes: one-channel-at-a time, all active or priority.
- Switchable inputs accept microphones or line level devices; mic- or line level out.
- Individual gain control and phantom power for each channel.
- Last In stays on for continuous ambience sound.
- Control voltage provided to trigger external device such as speaker switching and camera switching.

The outstanding performance enables effective managing of multi-microphone installations including corporate boardrooms, conference rooms, government buildings, houses of worship, classrooms, and many others.

Parts Identification

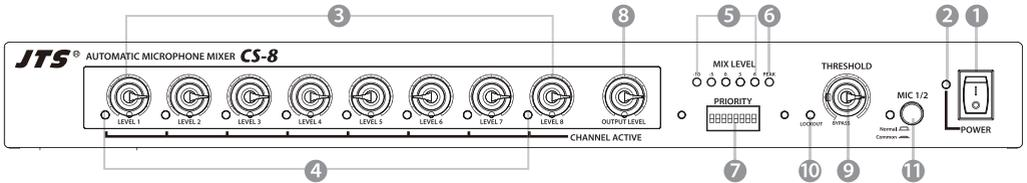

Front panel

- 1 **Power switch**
- 2 **Power ON/OFF indicator**
- 3 **Input level controls:** Adjust the sensitivity of microphone input.
- 4 **Active channel LED indicator:** Indicate a channel which is "active"
- 5 **MIX level LED meter:** Indicate RMS output level of the Automatic Mixer.
- 6 **Peak LED meter:** When the output reaches distortion level the LED will light.
- 7 **Priority switches:** The factory pre-set is in "Down" position. A switch in the "Up" position allows the respective microphone priority over other microphones. A combination of "Priority/non-priority" is allowed.
- 8 **Output level control:** The factory setting is fully clockwise. Turn counter-clockwise to reduce the mixer's output.
- 9 **Threshold/BYPASS control:** Set the reference level that must be exceeded for a microphone to be considered "in use", and prevent the ambient noise from accidentally triggering the microphones. "BYPASS" Mode will bypass all automatic function in the mixer system. All microphones are in "ON" status.
- 10 **Lockout LED indicator:** When "Lockout LED indicator" lights, the automatic function is activated to select a proper microphone.
- 11 **MIC 1/2:** When THRESHHOLD is ON, push down MIC1/2, the COMMON LED will light on. Then INPUT 1 and INPUT 2 will constantly have the same lowest priority which is good for background music. It is recommended to input a stereo signal into MIC 1 and MIC 2 as left and right channel.

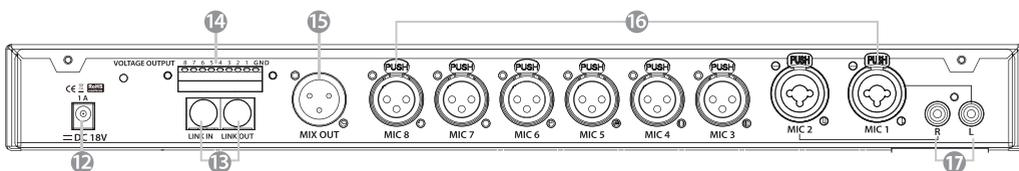

Rear panel

- 12 Power supply:** Require 18VDC, 1 A
- 13 Link In/Out:** For the daisy-chain multiple mixer system, the signal will pass through “Link In/ Out” connectors.
- 14 Voltage output:** Provide 0 or +5VDC (active high) to trigger external device for other applications.
- 15 MIX output:** Preset balanced XLR line-level output. Can be switched to mic-level output via internal switch. (Page 7)
- 16 MIC. inputs:** Balanced XLR microphone input for dynamic or condenser microphones. Can be switched to line-level input via internal switches. (Page 7) Preset phantom power on.
- 17 RCA INPUT (17):** When use RCA input please switch internal SW33 and SW34 to RCA position. Then the MIC1 and MIC 2 connectors will be bypassed.

Accessories

18 **AC/DC Adapter:** Input:AC100~240V,0.7A
Output:18V, 1.1A

19 **D8P-1 extension cable**

20 **RM-12 Rack mount kit**

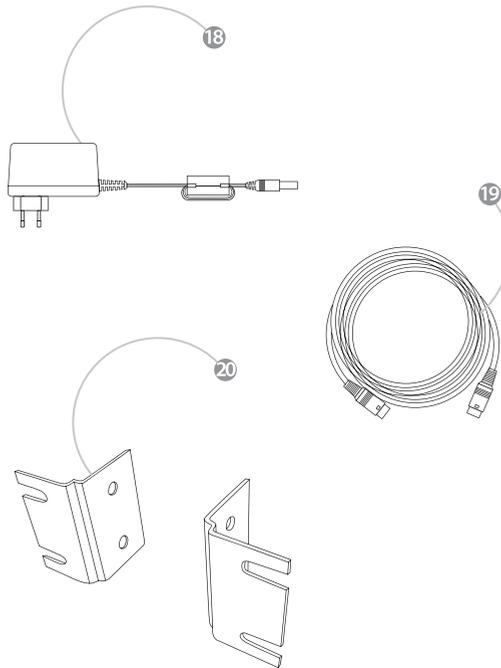

Installation and Operation

CS-8 Automatic mixer setup guides

1. Turn "Threshold/BYPASS control" at minimum threshold, immediately clockwise of the "BYPASS" setting.
2. Set all "Priority switches" to "down" position.
3. Turn all eight "Input level controls" fully counter-clockwise.
4. Connect the "AC/DC Adapter" to the Automatic mixer and the outlet.
5. Turn "Power switch" on. The "Power switch indicator" will light, and start self-test that would turn each microphone "on" and "off" sequentially.
6. Connect a microphone to "MIC 1" input and turn the "Input level control" to the "nine o'clock" position. The "Active channel LED indicator" will light when the microphone is active.
7. According to the "MIX level LED meter", adjust "Input level control" to a proper position. (Peak at rightest)
8. Gradually increase "Threshold/BYPASS control" until the "Lockout LED indicator" flashes when speaking at a normal level, preventing ambient noise from accidentally triggering the microphone.
9. Plug in up to seven microphones and adjust each respective "Input level control". It's not necessary to readjust the "Threshold/BYPASS control".
10. The system allows only one "non-priority" microphone to be used at one time. Only when one microphone stops using, the other one could be used.
11. Priority could be assigned to one or more microphone by moving "Priority switches" to "Up" position. Any microphone assigned to this setting will not be locked out by any other microphones.
12. "BYPASS" mode can be used at any time by simply switching "Threshold/BYPASS control" to "BYPASS" position. In this mode, the unit will function as a conventional eight-channel microphone mixer and all automatic functions are bypassed.

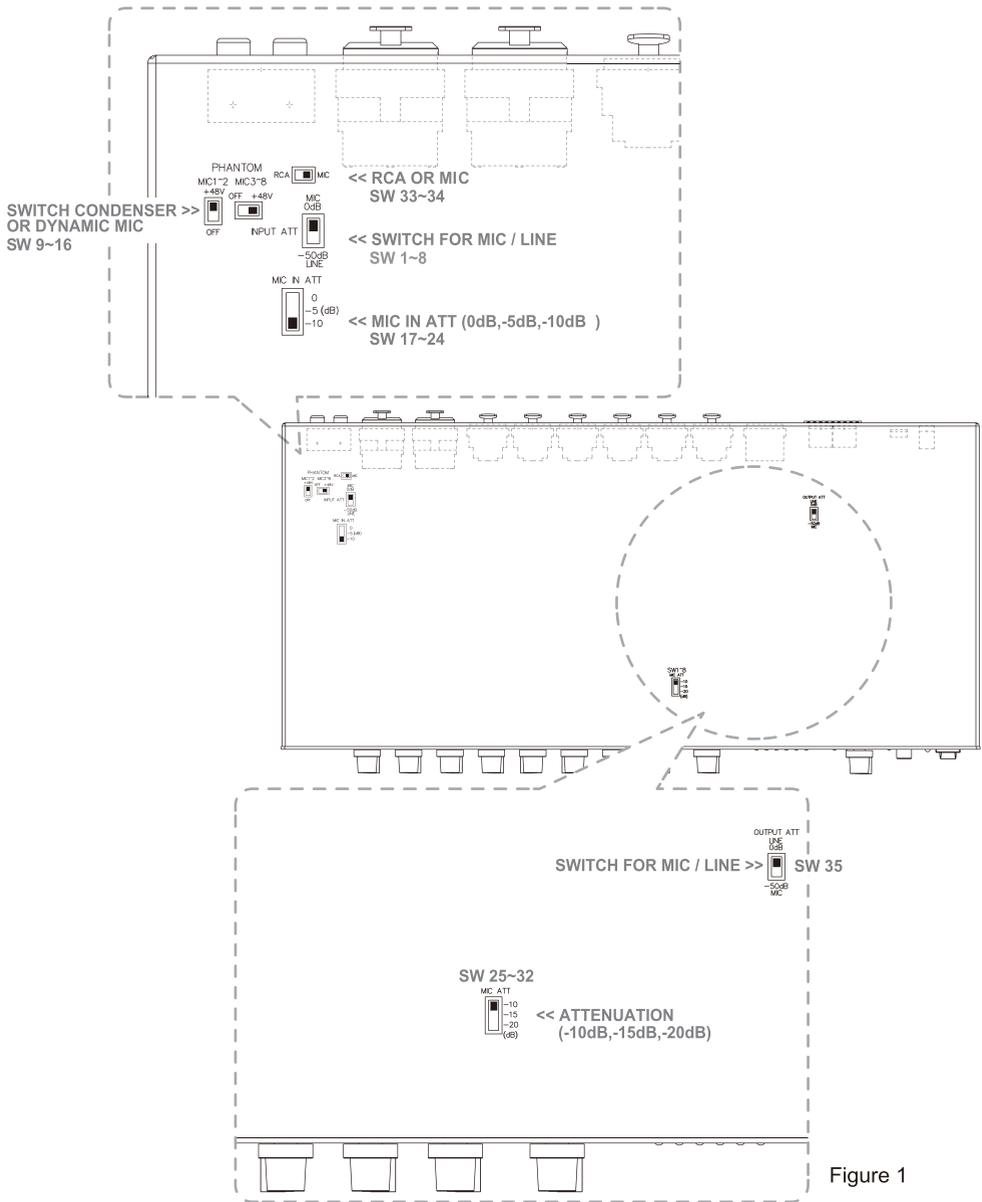

Figure 1

Internal Setup

CS-8 Automatic Mixer has a substantial gain range, allowing it to accept a wide variety of microphones. These settings are located inside the unit. Before setting, please unplugged the power cord, and remove the two screws on each side of the unit, and then remove the top cover. (Figure 1)

Preamplifier Gain

- MIC IN ATT (Factory pre-set is -10dB)
The internal switches are located on the circuit board designated by “SW 17~24”, for MIC 1~8 respectively. Moving the switch will change the gain by 5dB (From 0dB, -5dB or -10dB).
- Input attenuation switches (Factory pre-set is 0dB)
To accept the “line-level” input, the preamplifier gain may be reduced further. By changing the switches designated by “**SW 1~8**”, it will cause 50dB gain reduction for MIC 1~8 respectively.

Notice: Combination of mic in ATT and Input attenuation switches would reduce sensitivity by up to 60dB for each MIC input.

Output Attenuation (Factory pre-set is at line-level of 0dB)

The internal switch are located on the circuit board designated by “SW35”. Changing the setting to “MIC” would cause a 50dB reduction in output.

Microphone Attenuation (Factory pre-set is -10dB Comparing with priority mic)

If the number of microphones in use is high, it may increase the amount of “Microphone attenuation” of each microphone to maintain the total ambient noise level low. The “Microphone Attenuation switch” has three settings of -10dB, -15dB, and -20dB. The internal switches are located on the circuit board (CS-8 Main) designated by “SW 25~32”. Changing the setting to “-15 or -20” will cause the attenuation by “-15dB or -20dB” respectively.

Phantom Power (Factory pre-set is “+48V”)

Each of “MIC input” supplies +48V phantom power. If it’s required to disable the phantom power, change the setting of these switches to “OFF”. The switches are located in the internal circuit board designated by “SW 9~16” for MIC 1~8 respectively.

RCA and MIC

This switch is to change the input between MIC1/MIC2 and RCA R/ RCA L.

Daisy-chaining mixer

When more than eight microphones are used, the system could daisy-chain multiple CS-8 Automatic Mixers together through “Link In/Out” on the rear panel. Connect the #1 Mixer’s “Link Out” to the #2 Mixer’s “Link In” with “D8P-1” extension cable. Repeat it to connect enough Mixers for installation.

The last unit in the chain contains audio from all preceding mixers, and the combined output is then taken from the last mixer in the chain. (Figure 2)

Notice 1: Because the “Lockout information” is passed through “Link In/Out”, the whole chain system has only one microphone will stay on.

Notice 2: One or more mixers could be changed to “BYPASS” mode without affecting automatic functions in other mixers in the entire daisy-chain system.

Rack Mounting

Combined with “RM-12” rack mount kit, the CS-8 Automatic Mixer could be mounted in a 1U rack space.

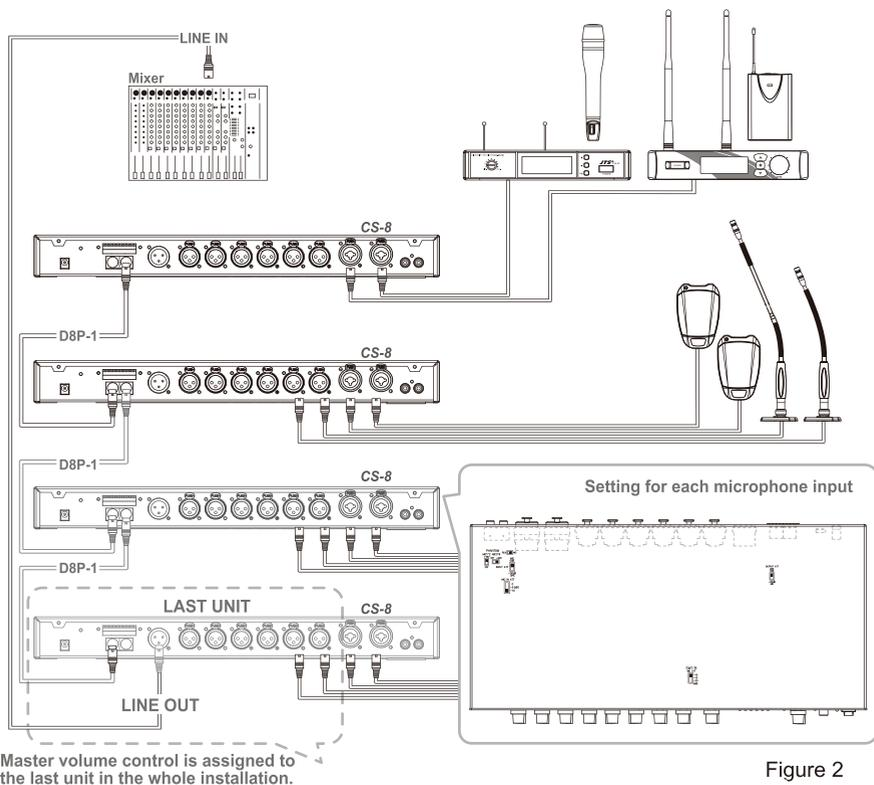
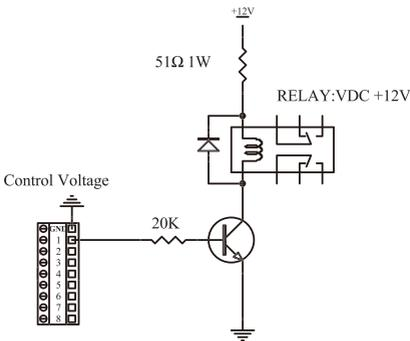

Figure 2

Voltage Output

When a microphone channel turn “on”, as indicated by a “Active channel LED indicator” on the front panel, the channel’s associated “Voltage Output” goes “high” (+5 VDC). This signal can be used by different applications, such as select video cameras.

Driving One device (Larger power)



Driving One LED

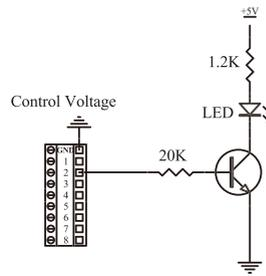

Specifications

Power Supply: 18VDC, 1A

Power Consumption: 18 Watts (include Adapter)

Fuse: 1A 250V

Impedance

Input

Type: XLR

Mic: 4.7K Ω

Line: 20K Ω

Output

Type: XLR

Mic: 300 Ω

Line: 200 Ω

Maximum Output Level

Line: >+17 dB

Maximum Gain: \geq 70dB

Internal Controls

Mic/Line attenuation: -50dB

Phantom Power: +48V \pm 2V

MIC IN ATT: 0dB, -5dB, -10dB

MIC Attenuation: -10dB, -15dB, -20dB

Output Attenuation: -50dB

Frequency Response: 35~20,000 Hz

THD% Input(1 KHz -40dB): <0.06%

Signal-To-Noise Ratio: >70dB

Voltage Output: : +5VDC \pm 0.2V

Weight: 2.25kg

Dimensions: 420.6mm(L)*198.5mm(W)
*44.2mm(H)