

# PRX900

SERIES SUBWOOFERS

## User's Guide

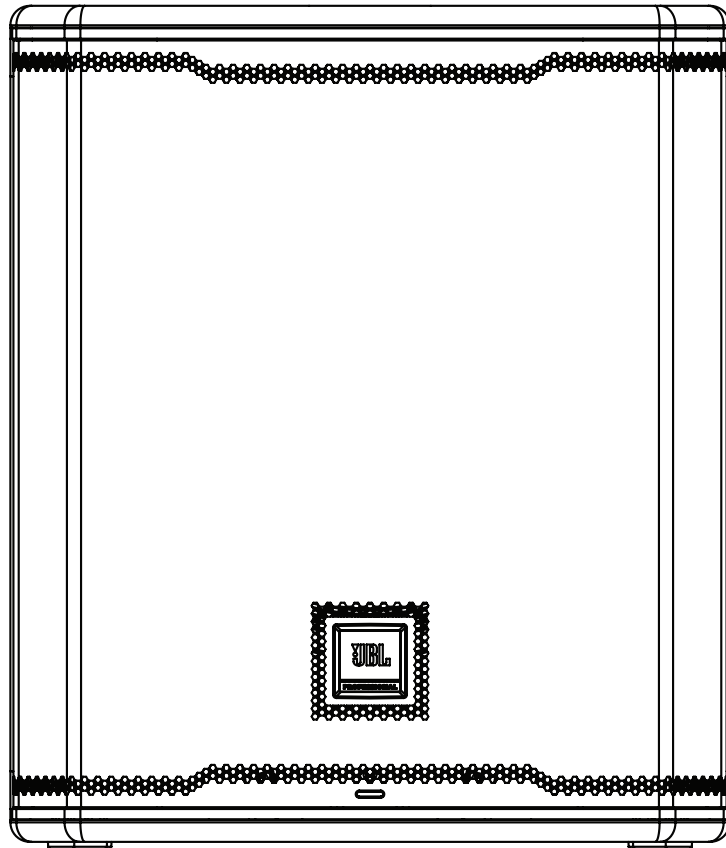

# CONTENTS

---

Safety Instructions .....	3
Precautions.....	5
Declaration of Conformity.....	6
Intro to PRX900 Series Subwoofers.....	7
Overview .....	8
Application Examples .....	9
Mixer Panel.....	12
Mixer Panel Functions .....	13
EasyNav LCD .....	16
Rigging Disclaimer .....	18
APP .....	19
PRX915XLF Specifications .....	20
PRX918XLF Specifications .....	21
Cables & Connectors.....	22
Warranty Information .....	23
Contact Information .....	24

# SAFETY INSTRUCTIONS

---



The PRX900 Series Subwoofers is covered by this manual is not intended for use in high moisture environments. Moisture can damage the speaker cone and surround and cause corrosion of electrical contacts and metal parts. Avoid exposing the speakers to direct moisture. Keep speakers out of extended or intense direct sunlight. The driver suspension will prematurely dry out and finished surfaces may be degraded by long-term exposure to intense ultra-violet (UV) light. The PRX900 Series Subwoofers can generate considerable energy. When placed on a slippery surface such as polished wood or linoleum, the speaker may move due to its acoustical energy output. Precautions should be taken to assure that the speaker does not fall off a stage or table on which it is placed.

## HEARING DAMAGE, PROLONGED EXPOSURE TO EXCESSIVE SPL

The PRX900 Series Subwoofers is capable of generating sound pressure levels (SPL) sufficient to cause permanent hearing damage to performers, production crew, and audience members. Caution should be taken to avoid prolonged exposure to SPL in excess of 85 dB.

## CARE & CLEANING

PRX900 Series Subwoofers may be cleaned with a dry cloth. Do not allow moisture into any of the openings in the system. Ensure that the system is unplugged from the AC outlet before cleaning.

THIS APPARATUS CONTAINS POTENTIALLY LETHAL VOLTAGES. TO PREVENT ELECTRIC SHOCK OR HAZARD, DO NOT REMOVE CHASSIS, MIXER MODULE, OR AC INPUT COVERS. NO USER SERVICEABLE PARTS INSIDE. REFER SERVICING TO QUALIFIED SERVICE PERSONNEL.

## WEEE Notice

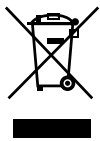

The Directive 2012/19/EU on Waste Electrical and Electronic Equipment (WEEE), which entered into force as European law on 14/02/2014, resulted in a major change in the treatment of electrical equipment at end-of-life.

The purpose of this Directive is, as a first priority, the prevention of WEEE, and in addition, to promote the reuse, recycling and other forms of recovery of such wastes so as to reduce disposal. The WEEE logo on the product or on its box indicating collection for electrical and electronic equipment consists of the crossed-out wheeled bin, as shown below.

This product must not be disposed of or dumped with your other household waste. You are liable to dispose of all your electronic or electrical waste equipment by relocating over to the specified collection point for recycling of such hazardous waste. Isolated collection and proper recovery of your electronic and electrical waste equipment at the time of disposal will allow us to help conserving natural resources. Moreover, proper recycling of the electronic and electrical waste equipment will ensure safety of human health and environment. For more information about electronics and electrical waste equipment disposal, recovery, and collection points, please contact your local city center, household waste disposal service, shop from where you purchased the equipment, or manufacturer of the equipment.

## RoHS Compliance

This product is in compliance with Directive 2011/65/EU and (EU) 2015/863 of the European Parliament and of the Council of 19. 31/03/2015 on the restriction of the use of certain hazardous substances in electrical and electronic equipment.

## REACH

REACH (Regulation No 1907/2006) addresses the production and use of chemical substances and their potential impacts on human health and the environment. Article 33 (1) of REACH Regulation requires suppliers to inform the recipients if an article contains more than 0.1% (per weight per article) of any substance(s) on the Substances of Very High Concern (SVHC) Candidate List ('REACH candidate list').

This product contains the substance "lead" (CAS-No. 7439-92-1) in a concentration of more than 0.1% per weight.

At the time of release of this product, except for the lead substance, no other substances of REACH candidate list are contained in a concentration of more than 0.1% per weight in this product.

**Note:** on June 27, 2018, lead was added to the REACH candidate list. The inclusion of lead in the REACH candidate list does not mean that lead-containing materials pose an immediate risk or results in a restriction of permissibility of its use.

- 
1. READ these instructions.
  2. KEEP these instructions.
  3. HEED all warnings.
  4. FOLLOW all instructions.
  5. DO NOT use this apparatus near water.
  6. CLEAN ONLY with dry cloth.
  7. DO NOT block any ventilation openings. Install in accordance with the manufacturer's instructions.
  8. DO NOT install near any heat sources such as radiators, heat registers, stoves, or other apparatus (including amplifiers) that produce heat.
  9. DO NOT defeat the safety purpose of the polarized or grounding type plug. A polarized plug has two blades with one wider than the other. A grounding type plug has two blades and a third grounding prong. The wider blade or the third prong are provided for your safety. If the provided plug does not fit into your outlet, consult an electrician for replacement of the obsolete outlet.
  10. PROTECT the power cord from being walked on or pinched, particularly at plugs, convenience receptacles, and the point where they exit from the apparatus.
  11. ONLY USE attachments/accessories specified by the manufacturer.
  12.  USE ONLY with a cart, stand, tripod, bracket, or table specified by the manufacture, or sold with the apparatus. When a cart is used, use caution when moving the cart/apparatus combination to avoid injury from tip-over.
  13. UNPLUG this apparatus during lightning storms or when unused for long periods of time.
  14. REFER all servicing to a qualified service personnel. Servicing is required when the apparatus has been damaged in any way, such as power-supply cord or plug is damaged, liquid has been spilled or objects have fallen into the apparatus, the apparatus has been exposed to rain or moisture, does not operate normally, or has been dropped.
  15. DO NOT expose this apparatus to dripping or splashing and ensure that no objects filled with liquids, such as vases, are placed on the apparatus.
  16. To completely disconnect this apparatus from the AC Mains, disconnect the power supply cord plug from the AC receptacle.
  17. Where the mains plug or an appliance coupler is used as the disconnect device, the disconnect device shall remain readily operable.
  18. DO NOT overload wall outlets or extension cords beyond their rated capacity as this can cause electric shock or fire.
  19. For adequate ventilation, do not install this equipment in a confident or enclosed space, such as a book case or similar unit. Product ventilation should not be impeded by covering the ventilation openings with items such as newspaper, tablecloths, curtains, etc.



The exclamation point, within an equilateral triangle, is intended to alert the user to the presence of important operating and maintenance (servicing) instructions in the literature accompanying the product.



The lightning flash with an arrowhead symbol within an equilateral triangle is intended to alert the user to the presence of uninsulated "dangerous voltage" within the product's enclosure that may be sufficient in magnitude to constitute a risk of electrical shock to persons.

**WARNING:** To reduce the risk of fire or electrical shock, do not expose this apparatus to rain or moisture.

**WARNING:** No naked flame sources – such as lighted candles –should be placed on the product.

**WARNING:** Equipment shall be connected to a MAINS socket outlet with a protective earthing connection.

# PRECAUTIONS

**WARNING:** This product is intended to be operated ONLY from the voltages listed on the back panel. Operation from other voltages other than those indicated may cause irreversible damage to the product and void the product's warranty. The use of AC Plug Adapters is cautioned because it can allow the product to be plugged into voltages in which the product was not designed to operate. If you are unsure of the correct operational voltage, please contact your local distributor and/or retailer. If the product is equipped with a detachable power cord, use only the type provided, or specified, by the manufacturer or your local distributor.

**OPERATING TEMPERATURE RANGE:** -10°C - 40°C (14°F - 104°F)



**WARNING:** Do Not Open! Risk of Electrical Shock. Voltages in this equipment are hazardous to life. No user-serviceable parts inside. Refer all servicing to qualified service personnel.

Place the equipment near a main power supply outlet and make sure that you can easily access the power breaker switch.

DO NOT UNDER ANY CIRCUMSTANCES OPERATE THE UNIT WITH THE WRONG VOLTAGE SELECTED. DOING SO MAY RESULT IN SERIOUS DAMAGE TO YOUR PA SYSTEM WHICH WILL NOT BE COVERED BY WARRANTY.

**FCC AND CANADA EMC COMPLIANCE INFORMATION:** This device complies with Part 15 of the FCC Rules. Operation is subject to the following two conditions

1. This device may not cause harmful interference, and (2) this device must accept any interference received, including interference that may cause undesired operation.

**CAUTION:** Changes or modifications not expressly approved by the manufacturer could void the user's authority to operate this device.

**NOTE:** This equipment has been tested and found to comply with the limits for a Class B digital device, pursuant to Part 15 of the FCC Rules. These limits are designed to provide reasonable protection against harmful interference in a residential installation. This equipment generates uses and can radiate radio frequency energy and, if not installed and used in accordance with the instructions, may cause harmful interference to radio communications. However, there is no guarantee that interference will not occur in a particular installation. If this equipment does cause harmful interference to radio or television reception, which can be determined by turning the equipment off and on, the user is encouraged to try to correct the interference by one or more of the following measures: Reorient or relocate the receiving antenna. Increase the separation between the equipment and receiver. Connect the equipment into an outlet on a circuit different from that to which the receiver is connected. Consult the dealer or an experienced radio/TV technician for help.

**CAUTION:** This product is for non-residential use only.

**WARNING:** This equipment is compliant with Class B of CISPR 32. In a residential environment this equipment may cause radio interference.

CAN ICES-003(B)/NMB-003(B)



Protective earthing terminal. The apparatus should be connected to a mains socket outlet with a protective earthing connection.

# DECLARATION OF CONFORMITY

---

**WIRELESS TRANSMITTER COMPLIANCE INFORMATION:** The term “IC:” before the radio certification number only signifies that Industry Canada technical specifications were met.

Le terme «IC:» avant le numero de certification radio signifie seulement que les specifications techniques d'Industrie Canada ont ete respectees.

This device contains licence-exempt transmitter(s)/receiver(s) that comply with Innovation, Science and Economic Development Canada's licence-exempt RSS(s). Operation is subject to the following two conditions (1) this device may not cause harmful interference, and (2) this device must accept any interference, including interference that may cause undesired operation of the device.

Cet appareil contient des émetteurs / récepteurs exemptés de licence conformes aux RSS (RSS) d'Innovation, Sciences et Développement économique Canada. L'exploitation est autorisée aux deux conditions suivantes : (1) l'appareil ne doit pas produire de brouillage, et (2) l'utilisateur de l'appareil doit accepter tout brouillage radioélectrique subi, même si le brouillage est susceptible d'en compromettre le fonctionnement.

This equipment complies with FCC and IC radiation exposure limits set forth for an uncontrolled environment. This equipment should be installed and operated with minimum distance 20cm between the radiator and your body. This transmitter must not be co-located or operating in conjunction with any other antenna or transmitter.

Cet appareil est conforme a FCC et IC !'exposition aux rayonnements limites fixees pour un environnement non controle. Cet appareil doit etre installe et utilise avec une distance minimale de 20cm entre le radiateur et votre corps. Cet transmetteur ne doit pas etre cositue ou operant en liaison avec toute autre antenne ou transmetteur.

## EU COMPLIANCE INFORMATION:

Hereby, HARMAN Professional, Inc., declares that the equipment type PRX900 Series Subwoofers is in compliance to the following: European Union Restriction of Hazardous Substances Recast (RoHS2) Directive 2011/65/EU; European Union WEEE (recast) Directive 2012/19/EU; European Union Registration, Evaluation, Authorization and Restriction of Chemicals (REACH) Directive 1907/2006; European Radio Equipment Directive (RED) 2014/53/EU

You may obtain a free copy of the full Declaration of Conformity by visiting:  
<http://www.jblpro.com/www/product-support/downloads>

This product contains batteries that are covered under the 2006/66/EC European Directive, which cannot be disposed of with normal household waste. Please follow local regulations.

## WIRELESS FREQUENCY RANGE AND WIRELESS OUTPUT POWER:

2402MHz - 2480MHz

6.00mW

## Prevention of hearing loss



**Caution:** Permanent hearing loss may occur if earphones or headphones are used at high volume for prolonged periods of time.

**Note:** To prevent possible hearing damage, do not listen at high volume levels for long periods.

## CLASS B PRODUCT:

警告

此为B级产品。在生活环境中，该产品可能会造成无线电干扰。在这种情况下，可能需要用户对干扰采取切实可行的措施。

## ENVIRONMENTAL:



此标识适用于在中华人民共和国销售的电子信息产品。标识中间的数字为环保实用期限的年数。

Este equipamento não tem direito à proteção contra interferência prejudicial e não pode causar interferência em sistemas devidamente autorizados

# INTRO TO PRX900 SERIES SUBWOOFERS

## GETTING STARTED

Congratulations on your purchase of JBL Professional PRX900 Series loudspeakers! We know you are anxious to get up and running as fast as possible, which is why you are reading this section. The following will help you get set up as soon as possible.

## Packaging Contents

Your PRX900 Series Subwoofers should include:

- 1 PRX900 Series Subwoofer Cabinet
- 1 6' (2m) AC Power Cable
- 1 QSG

## Unboxing

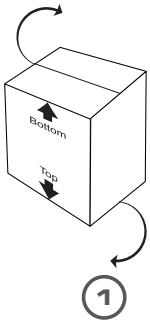

Flip box/packaging on its top, e.g. top resting on the ground, bottom facing up, etc.

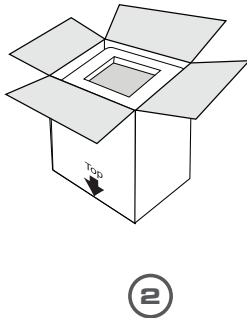

Open bottom of box/packaging.

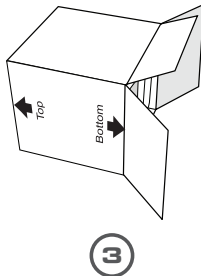

Carefully lay box/packaging on its side.

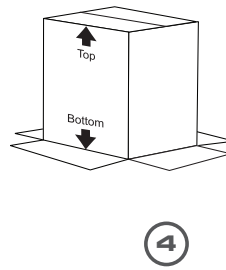

Lift and flip box/packaging, firmly resting onto its bottom, e.g. top facing up, etc.

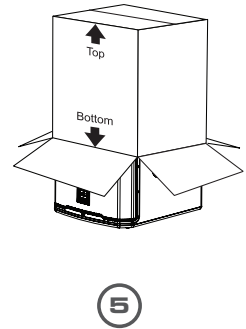

Carefully lift to remove the box/packaging to reveal speaker.



Plug AC cable into inlet



Power up

# OVERVIEW

---

## SETTING UP

### How to set up

1. Insert input into desired channel
2. Slowly turn the Main knob to increase your main volume.
3. Adjust the Channel Gain knobs until your desired volume is achieved.

### How to turn on/off

Press the Power Button for .5 of a second to engage power.

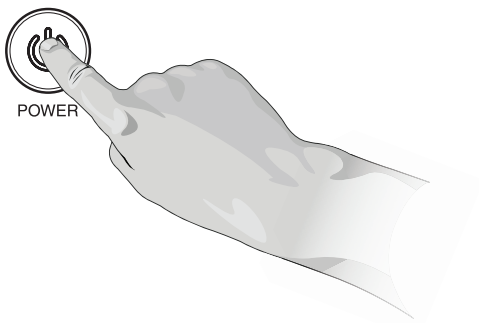

## P.A. BASICS

A mixing board is actually a very simple device that takes the audio input signals (from the input channels) and “mixes” them to the outputs. The mixing board controls will typically enable the user to blend the input channel signal levels, affect their tone, and adjust each channel's reverb level. The signal is then fed from the mixing board to the amplifiers and onto the speakers. PRX915/918XLF is a self-contained PA system, which includes a mixing board, amplifiers, and speakers.

## GETTING ACQUAINTED WITH PRX900 SERIES SUBWOOFER

The powered mixer section of the PRX915/918XLF Series Subwoofers houses the mixing board and power amplifier. Here, line level sources like powered speakers and external mixers can be connected.

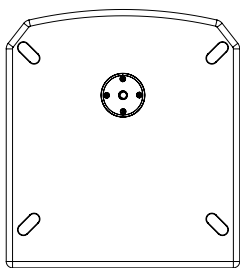

Top View

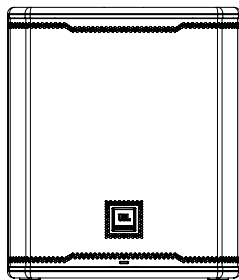

Front View

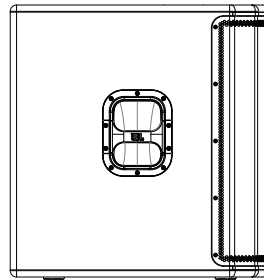

Left View

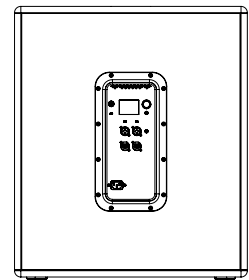

Rear View



# APPLICATION EXAMPLES

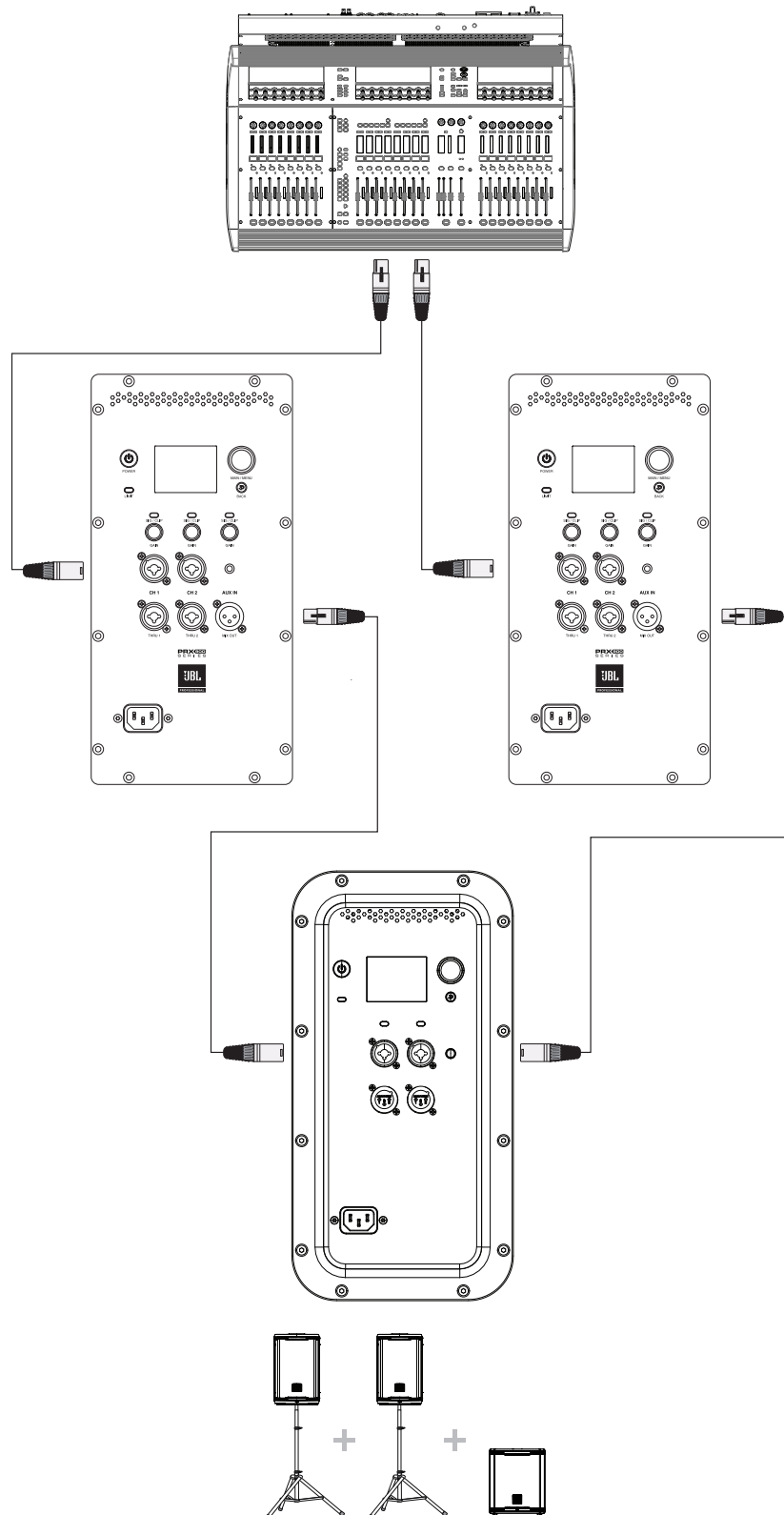

## SMALL PA USING TWO SYSTEMS AS MONITORS WITH SHARED MIX OUT FUNCTION

PA1 and PA2 CH1 XLR-1/4" Combo inputs mixed to Sub

# APPLICATION EXAMPLES

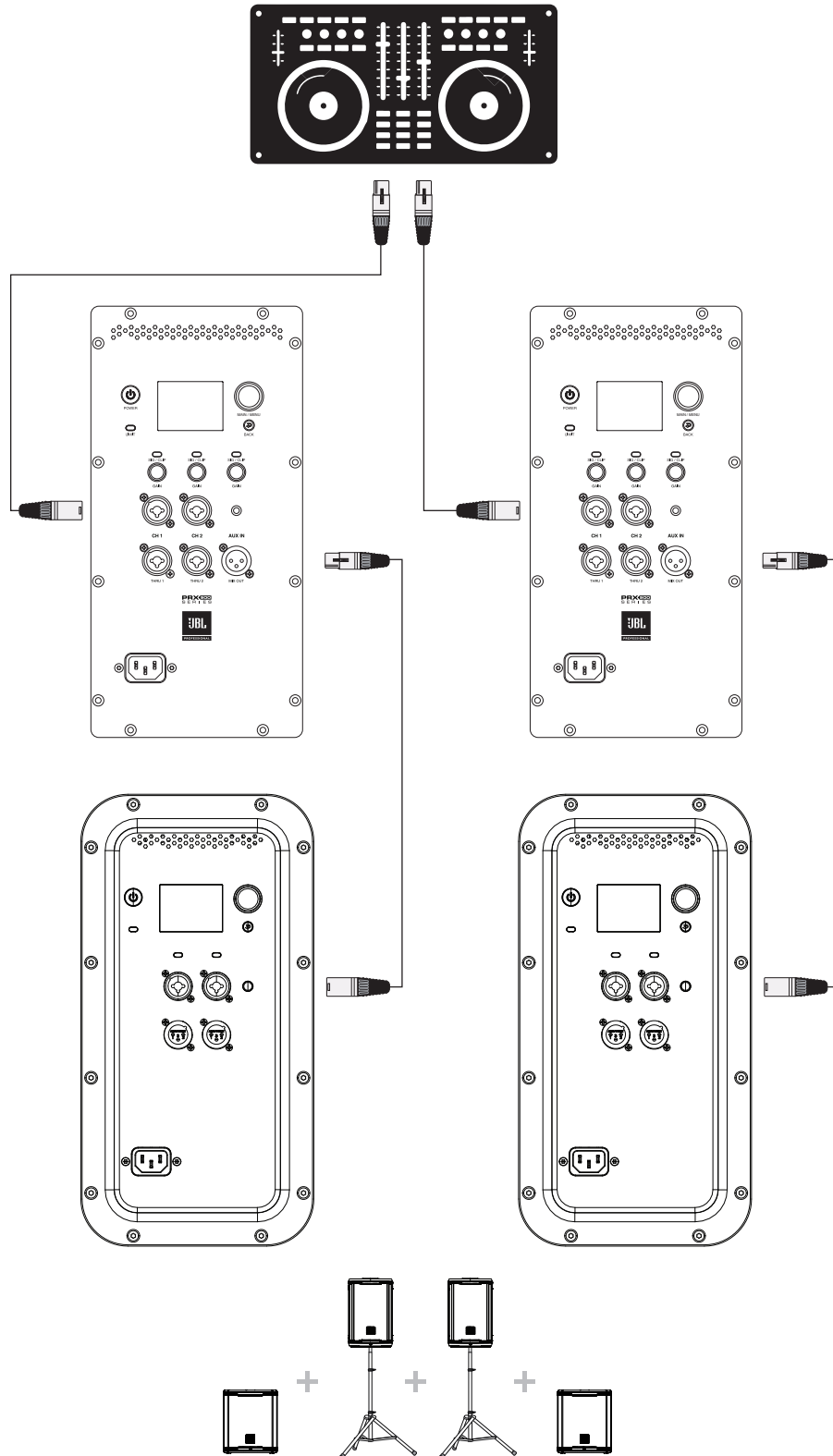

## DJ CONSOLE USING TWO SYSTEMS AS MONITORS USING MIX OUT FUNCTIONS

PA1 and PA2 CH1 XLR-1/4" Combo inputs mixed to individual Subs

# APPLICATION EXAMPLES

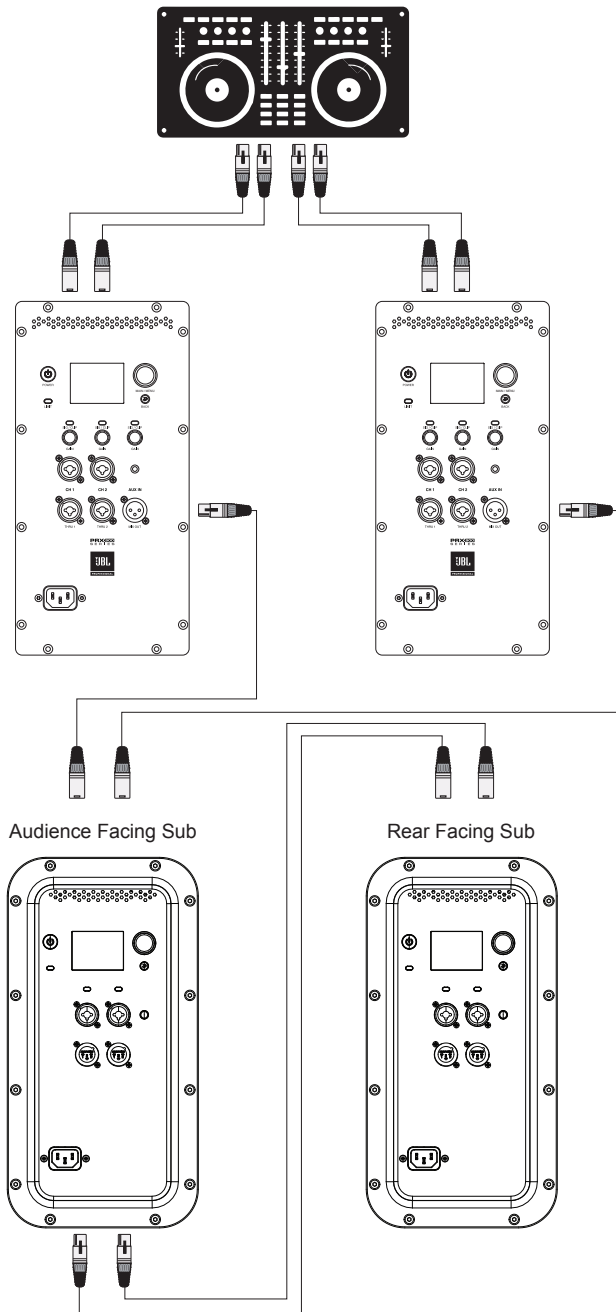

## CARDIOID

- Cardioid mode helps subwoofer performance become more directional and easier to control. Users can experience +3-5db of low frequency extension on audience side and up to -10-17db of reduction on rear/stage side.
- To use cardioid mode with 2 units of PRX915XLF/PRX815XLF Series Subwoofers, place them next to each other or stacked.
- Adjust the audience firing subwoofer's preset as following for:  
PRX915XLF:- 80Hz  
PRX815XLF:- 100Hz
- Adjust the rear-firing subwoofer's preset to CARDIOID
- Run BOTH Full range PRX900 series speakers from the pass through to the CH1 and CH2 on the audience firing PRX900 Series Subwoofers.
- Run THRU each channel of the front firing sub into each channel of the rear-firing sub.
- Adjust volume accordingly.

**MICROPHONE**  
(presenter or speaker) Subwoofer positioning distance

**Microphone (speaker/presenter) stands before subwoofer.**

To prevent any unnecessary feedback, please:  
Position Microphone at least 2m (6ft) from a speaker  
Do not stand directly in front of a speaker

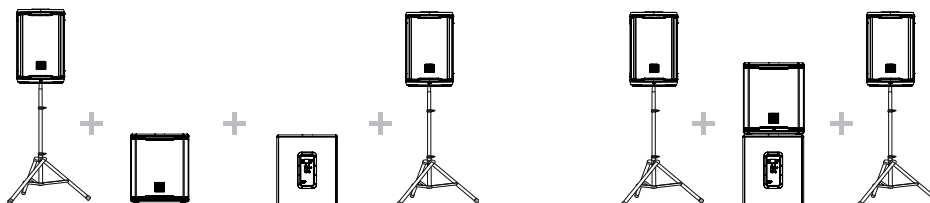

## CARDIOID

PA1 and PA2 CH1 XLR-1/4" Combo inputs mixed to individual Subs

# MIXER PANEL

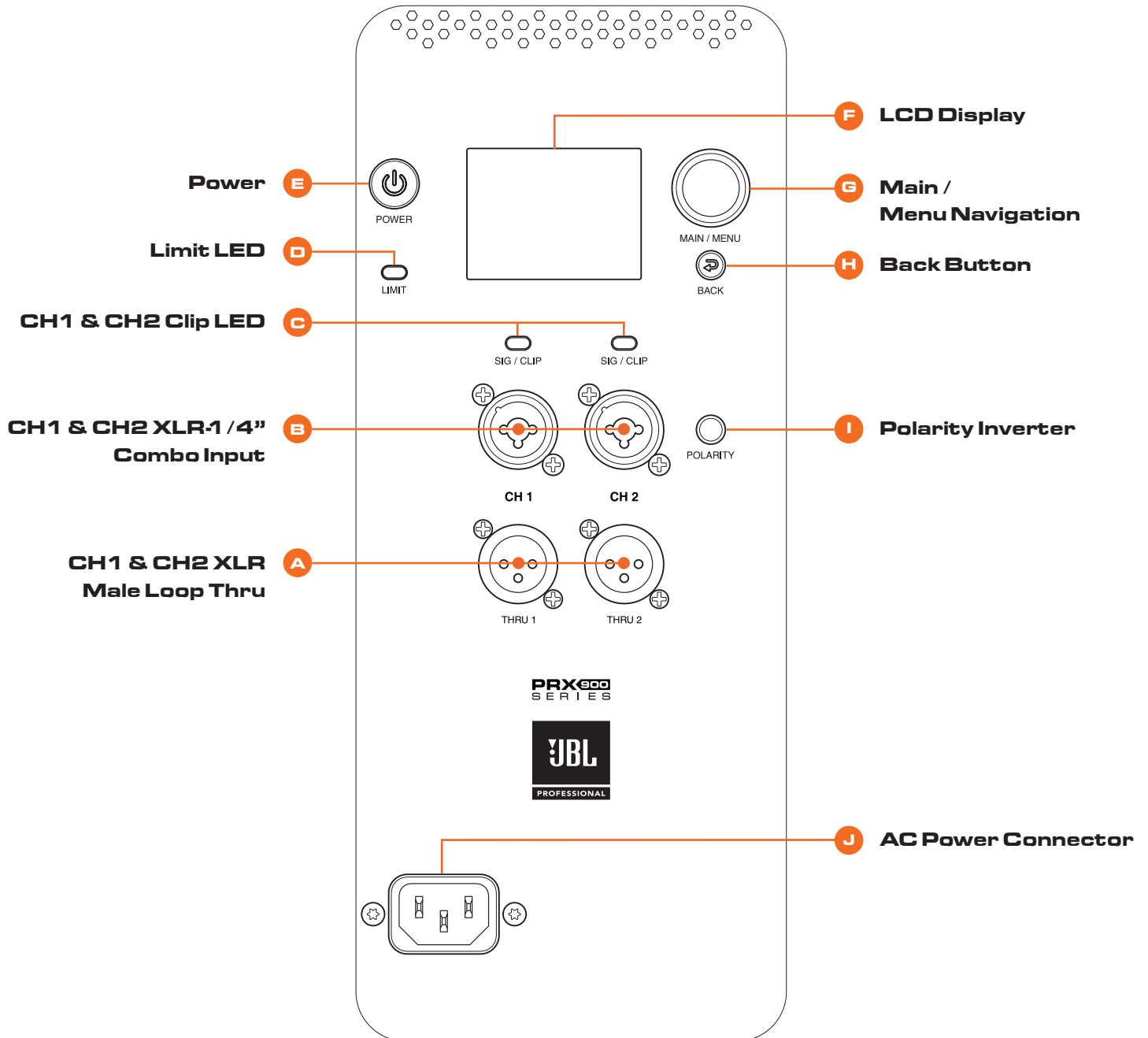

# MIXER PANEL FUNCTIONS

---

## A. CH 1 & CH 2 XLR Male Loop Thru

This XLR output connector provides a method of sending audio out to an external source. The XLR male connector will take a direct feed of the input on its respective channel, and send it out at the same level.

## B. CH1 & CH 2 XLR-1/4" Combo Input

XLR – 1/4" combination connector (1 for each input) are used for the analog audio inputs.

## C. CH1 & CH2 Signal/Clip LED

These LEDs indicate signal and clipping on these channels.

## D. Limit LED

Amplifier is reaching clip.

## E. Power Button

The Power Button is a momentary push button. It is used to toggle the unit between the On and Off states. When in the Off state, a short press and release of the Power Button will put the unit into the On state.

## F. LCD Panel

The LCD is used to display basic diagnostic information and allow access to more advanced features through a menu system. See the LCD GUI specification for more details on the LCD menu system, features, and navigation. The LCD will refresh at approximately 4Hz and is not suitable for meters or any other fast motion items

## G. Main / Menu Navigation

Controls LCD Display

- Rotary encoder: In Menu - Clockwise down menu/Anti-clockwise up menu
- Press to select menu item
- + On Home screen, Main Volume increase by rotating the knob clockwise.
- + On Home screen, Main Volume decrease by rotating the knob counterclockwise.

## H. Back Button

Press to return to previous menu item

## G. CH2 XLR-1/4" Combo Input

XLR – 1/4" combination connector (1 for each input) are used for the analog audio inputs.

## H. CH 2 XLR Male Loop Thru

This XLR output connector provides a method of sending audio out to an external source. The XLR male connector will take a direct feed of the input on its respective channel, and send it out at the same level.

## I. Polarity Inverter

Inverts the electrical polarity

## J. AC Power Connector

Inlet adapter for A/C power cable

# MIXER PANEL FUNCTIONS

I/O

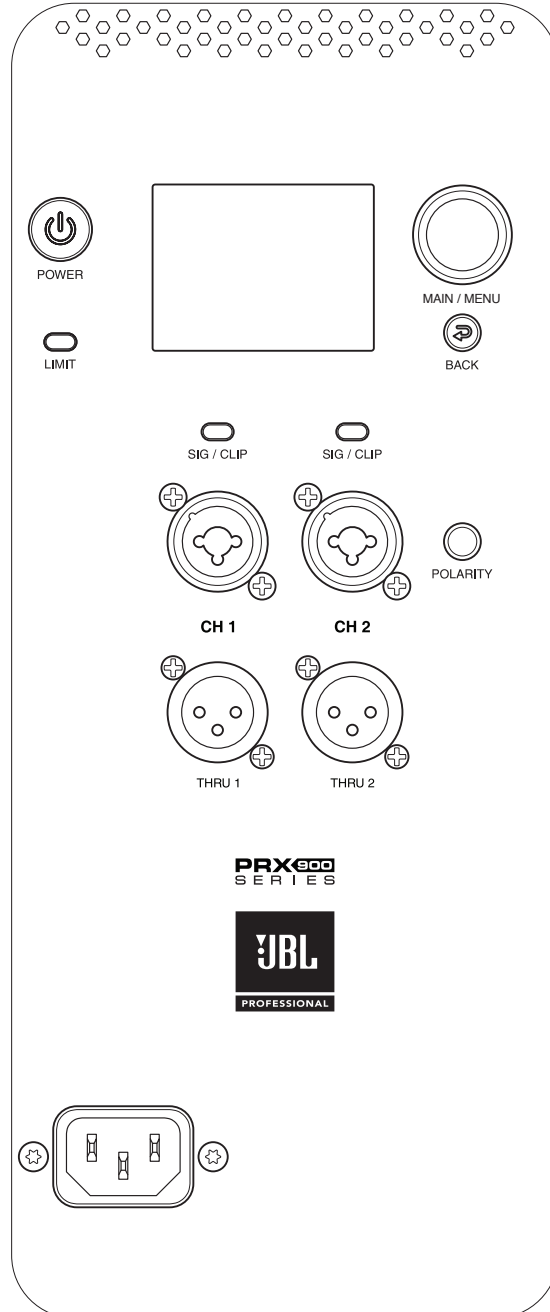

# MIXER PANEL FUNCTIONS

---

## Knobs and Functions

The PRX915/918XLF comes equipped with push button rotaries to make for easy navigation and hardware usage.

- A single press of the MAIN/MENU knob will open up the main menu.
- Pressing and holding the MAIN/MENU knob for 2s will mute the SUBWOOFER.

## Buttons and Functions

- The POWER button turns on/off the speaker. Hold for .5s to turn on the speaker and 2s to turn off the speaker.
- The BACK button will return you to the previous menu screen.

# EASYNV LCD

---

## Intro to the EasyNav LCD

### Main Menu

- Pressing the Main/Menu rotary at any time will take you to the PRX915/918XLF' main menu. Here, users can access the main menu functions of the PRX900 Series Subwoofers.
- DBX Driverack output - DriveRack is a line of hardware products produced by Harman's dbx brand. These rack mount signal processors provide detailed control for final processing and crossovers before feeding the mix to one or more speakers. This DriveRack functionality embedded into PRX900 is designed to optimize the combination of speaker and Pass Thru outputs built into this JBL speaker.
- The Output EQ is a package of filter adjustments on the main mix before the audio feeds to the amp and speaker. It includes a collection of easy to select preset curves for common subwoofer use cases. Each preset can also be loaded into the Custom preset for detailed user adjustable of output parametric EQ's. The user has adjustments for individual band level, frequency, and width ("Q").
  - "Output EQ" On/Off enables or bypasses the current settings in the output EQ processor.
  - "Presets" enables rotation of the Main/Menu knob to view and select from the Output EQ presets.
    - Scroll the menu to "Presets" and press the MAIN/MENU knob.
    - Rotate the MAIN/MENU knob to view the available presets.
    - Click the MAIN/MENU knob to load the currently listed preset.
    - Users can load the Custom preset, then double click the MAIN/MENU knob to open the Master EQ editing page. Inside this graph display page you may rotate the MAIN/MENU knob to a specific parametric EQ number and click the MAIN/MENU knob again to select to edit the gain (plus or minus in dB), filter frequency, or "Q" (i.e. adjust the filter width.)
      - Users can load any preset as a starting point, then scroll down and adjust any setting to load the current curve as the Custom preset for further editing. A confirmation dialog will appear, warning the user that doing this will remove the current Custom preset settings and load it with the currently viewed settings.
    - Flat – a flat tuned subwoofer preset
    - 80hz – adjusts the subwoofer crossover point to 80hz
    - 100hz – adjusts the subwoofer crossover point to 100hz
    - 120hz – adjusts the subwoofer crossover point to 120hz
    - Cardioid – adjusts the tuning, delay and polarity of the subwoofer to optimize its usage in cardioid mode. For more on this, please see the Cardioid section of the guide.
- Speaker Delay
  - Signal delays are used when multiple speakers are in use but speakers are at different distances from the audience.
  - Examples:
    - A subwoofer in front of the stage, while this full range speaker in on the stage. In this configuration, the Pass Thru XLR to subwoofer will need to be slightly delayed to make up for its closer position to the audience.
  - Time Alignment Basics:



- 
- To compensate for different distances, determine the speaker farthest from the audience and delay other speakers with the same signal to “time align” with the speaker farthest away from the audience.
  - Sound travels through air at average humidity and room temperature at about 1.1 feet per ms. Measure the difference in distance of each speaker feeding the audience. Feed the speaker farthest from the audience with no time alignment delay. Set delays for the other closer speakers based on their distance ahead of the farthest back speaker. Measure the distance difference and enter 1 ms per 1.1 feet that each speaker is ahead of the farthest back speaker in your configuration. Time alignment is not perfect as not all audience positions measure the same speaker distance differences.
  - The PRX915/918XLF offer 20ms of speaker delay on it’s input stage.
  - Polarity – This inverts the polarity of the subwoofer. OFF indicates the woofer is in standard polarity. ON means the polarity of the subwoofer is reversed.

## Settings

- “BT Control Pairing” enables Bluetooth control pairing for up to 30 seconds with the JBL Pro Connect app. This turns off when a pairing has been made, or after 30 seconds. When pairing with the app, please initiate control pairing first. Select the speaker in the “Add Speakers” menu. The speaker will send a 4-digit pin back to the LCD. Confirm this using the MAIN/MENU knob.
- “LCD Contrast” allows the user to adjust the LCD contrast between 0 and 100%.
- “Firmware Version” shows the current firmware version loaded onto the speaker.
- “Factory Reset” resets all settings in the speaker to factory default, including Bluetooth communication pairing.
- BLE Firmware Version - this is the version of BLE firmware loaded on your speaker.
- “System lock” locks out all hardware operation from the speaker.
  - To initiate system lock, press and hold the POWER button and the BACK button until all LEDs flash and a LOCK icon appears in the top left corner of the LCD.  
OR  
Navigate to the System Lock field in the settings menu, and select CONFIRM.
  - To disable system lock, press and Hold the POWER button and the BACK button until all the LEDs flash the lock icon disappears from the top left corner.  
OR  
Remove AC power and reboot the system.

# RIGGING DISCLAIMER

---

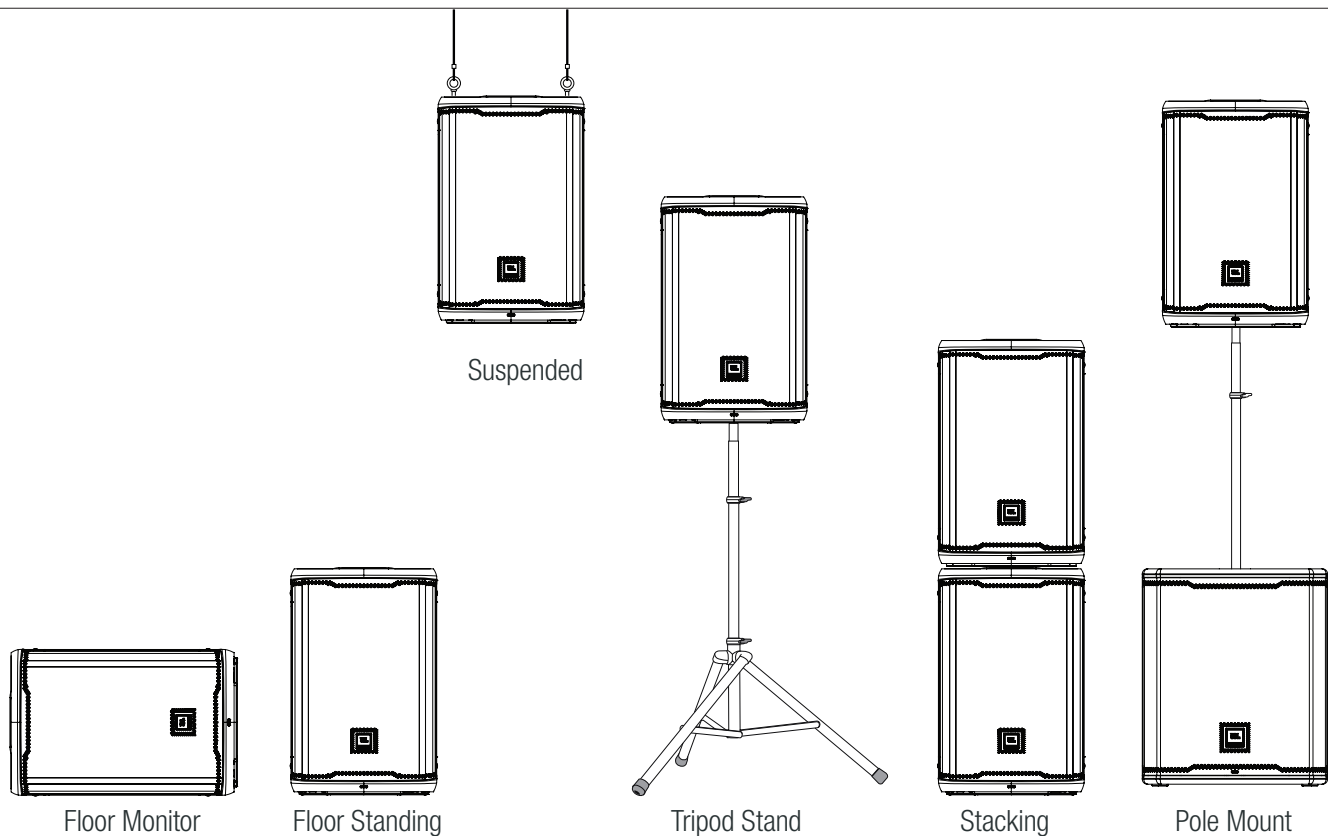

## **Only experienced professionals should attempt to suspend the speakers.**

For permanent installation applications utilizing the M10 suspension points, JBL Professional recommends the use of three (3) M10 x 1.5 thread pitch forged shoulder steel eyebolts with an 18-20mm threaded shaft, along with fender washers, rated for overhead suspension. Users unfamiliar with safe rigging practices should not attempt to suspend loudspeakers.

## **Raise the speakers as high as possible.**

For best results try to get the high frequency horn at least 2 to 4 feet above the heads of the audience. If the speakers are too low, the people in the back of the audience will not receive the best quality sound.

Place the speakers between the microphones and the audience.

Feedback occurs when the microphones pick up sound from the speakers and “feed” the sound back through the sound system. If space is limited, point the speakers away from the microphones to reduce feedback.

## **Locate the speakers away from turntables.**

Low-frequency feedback occurs when the output of the speaker is picked up by the tone arm of the turntable and is re-amplified. A heavy, solid turntable base and shock mounting can also reduce this type of feedback in DJ applications.

## **Use more speakers in large or highly reverberant spaces.**

Spreading speakers throughout these spaces will produce much better sound than trying to compensate with loudness level or equalization. For very long distances, the use of another set of speakers with time delay is recommended.

Stand speakers upright for PA - Tilt the speakers back on the side for stage monitoring. Upright stance provides even coverage over a wide area. EON speakers are also designed with two slanted positions for stage monitoring applications.

## JBL Pro Connect

The JBL Pro Connect app is a Bluetooth Low Energy control application used to remotely control the features within the PRX900 Series Subwoofer. The app is a free download on iOS and Android.

It is recommended that all users download the app and ensure their unit is operating on the latest firmware for the best experience.

## Firmware Update

If a firmware update fails on the PRX900 Series Subwoofers, please unplug the speaker, wait 1s before plugging back in and trying again.



# PRX915XLF SPECIFICATIONS

---

## TECHNICAL SPECIFICATIONS

System Type	15IN Powered Subwoofer
Woofers Model	915SG
Woofers Size	15"
Woofers Magnet	Ferrite
Woofers Voice Coil	3"
Transducer Impedance	Rated: woofers: 4Ω
Max SPL	131dB @1m/2Pi
Freq Range -10	36Hz - 98Hz (2Pi)
Freq Range -3	40Hz - 87Hz (2Pi)
Hor Dispersion	Omni
Vert Dispersion	Omni
Crossover Frequency	80Hz, 100Hz, 120Hz Selectable
Power Rating	2000W peak
AC Power Input	100-230Vrms 50-60Hz
Cooling	Natural convection, No fan
LED Indicators	Limit, 2x SSM Input
Input Impedance	100KΩ Balanced
Input Gain	-100 to +12dB
I/O	x2 Combo inputs x2 XLR pass through outputs
Cabinet	18mm Plywood + Duraflex
Grille	Powder coated Steel , T=1.5mm
Suspension/Mount	Pole mount on top surface
Handles	Side Handle x2
Net Weight	28.6kg
Gross Weight	33.6kg
Product Dims	549 x 480 x 580 (H x W x D mm)
Shipping Dims	594 x 692 x 600 (H x W x D mm)

# PRX918XLF SPECIFICATIONS

## TECHNICAL SPECIFICATIONS

System Type	18IN Powered Subwoofer
Woofer Model	918SG
Woofer Size	18"
Woofer Magnet	Ferrite
Woofer Voice Coil	4"
Transducer Impedence	Rated: woofer: 4Ω
Max SPL	134dB @1m/2Pi
Freq Range -10	30Hz - 110Hz (2Pi)
Freq Range -3	35Hz - 92Hz (2Pi)
Hor Dispersion	Omni
Vert Dispersion	Omni
Crossover Frequency	80Hz, 100Hz, 120Hz Selectable
Power Rating	2000W Peak
AC Power Input	100-230Vrms 50-60Hz
Cooling	Natural convection, No fan
LED Indicators	Limit, 2x SSM Input
Input Impedence	100KΩ Balanced
Input Gain	-100 to +12dB
I/O	x2 Combo inputs x2 XLR pass through outputs
Cabinet	18mm Plywood + Duraflex
Grille	Powder coated Steel , T=1.5mm
Suspension/Mount	Pole mount on top surface
Handles	Side Handle x2
Net Weight	40.7kg
Gross Weight	47.5kg
Product Dims	693 x 591 x 654 (H x W x D mm)
Shipping Dims	740 x 768 x 705 (H x W x D mm)

# CABLES & CONNECTORS

XLR/F to XLR/M Microphone Cable	The standard cable for interconnection of microphone and line level signal in professional audio systems. • Microphone to mixer
TRS (balanced) 1/4 inch (6.35mm) phone jack to XLR/M	For connecting balanced devices with 1/4 inch (6.35mm) phone and may be used interchangeably.
TRS (unbalanced) 1/4 inch (6.35mm) phone jack to XLR/M	For connections of instruments with unbalanced outputs to balanced XLR inputs.
TS (unbalanced) 1/4 inch phone (6.35mm) jack to XLR/M	This cable is electrically identical to "TRS" (unbalanced) 1/4 inch (6.35mm) phone and may be used interchangeably.
XLR/M to RCA (phono) cable	Connects consumer audio products and some DJ mixer outputs to professional audio equipment inputs
TRS 1/4 inch Phone jack to dual 1/4 inch (6.35mm) Phone jack	Splits a stereo output into separate left/right signals.
TRS 1/4 inch Phone jack to dual 1/4 inch (6.35mm) Phone jack	Change to a TRS mini-phone jack to connect to the output of a portable. MP3/CD – player and computer sound cards to a mixer.
XLR/F to XLR/M audio ground lift	Only with balanced in - and outputs

**XLR/F to XLR/M Microphone Cable**

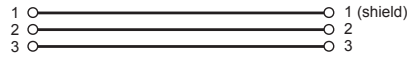

**TRS (Balanced) 1/4" Phone to XLR/M Cable**



**TRS (Unbalanced) 1/4" Phone to XLR/M Cable**



**TS (Unbalanced) 1/4" Phone to XLR/M Cable**

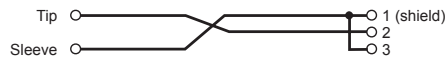

**XLR/M to RCA (Phono) Cable**

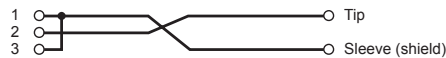

**TS (Unbalanced) 1/4" Phone to RCA (Phono) Cable**

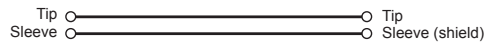

**TRS 1/4" Phone to dual TS 1/4" Phone Cable**

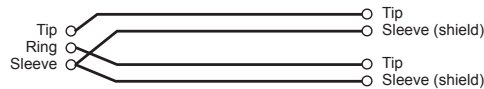

**XLR/F to XLR/M Audio Ground Lift Adapter**

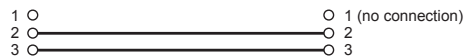
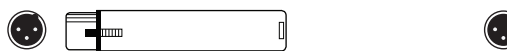

# WARRANTY INFORMATION

---

The JBL Limited Warranty on professional loudspeaker products (except for enclosures) remains in effect for five years from the date of the first consumer purchase. JBL amplifiers are warranted for three years from the date of original purchase. Enclosures and all other JBL products are warranted for two years from the date of original purchase.

## Who Is Protected By This Warranty?

Your JBL Warranty protects the original owner and all subsequent owners so long as: A.) Your JBL product has been purchased in the Continental United States, Hawaii or Alaska. (This Warranty does not apply to JBL products purchased elsewhere except for purchases by military outlets. Other purchasers should contact the local JBL distributor for warranty information.); and B.) The original dated bill of sale is presented whenever warranty service is required.

## What Does The JBL Warranty Cover?

Except as specified below, your JBL Warranty covers all defects in material and workmanship. The following are not covered: Damage caused by accident, misuse, abuse, product modification or neglect; damage occurring during shipment; damage resulting from failure to follow instructions contained in your Instruction Manual; damage resulting from the performance of repairs by someone not authorized by JBL; claims based upon any misrepresentations by the seller; any JBL product on which the serial number has been defaced, modified or removed.

## Who Pays For What?

JBL will pay all labor and material expenses for all repairs covered by this warranty. Please be sure to save the original shipping cartons because a charge will be made if replacement cartons are requested. Payment of shipping charges is discussed in the next section of this warranty.

## How To Obtain Warranty Performance

If your JBL product ever needs service, write or telephone us at JBL Incorporated (Attn: Customer Service Department), 8500 Balboa Boulevard, PO. Box 2200, Northridge, California 91329 (818/893-8411). We may direct you to an authorized JBL Service Agency or ask you to send your unit to the factory for repair. Either way, you'll need to present the original bill of sale to establish the date of purchase. Please do not ship your JBL product to the factory without prior authorization. If transportation of your JBL product presents any unusual difficulties, please advise us and we may make special arrangements with you. Otherwise, you are responsible for transporting your product for repair or arranging for its transportation and for payment of any initial shipping charges. However, we will pay the return shipping charges if repairs are covered by the warranty.

## Limitation of Implied Warranties

ALL IMPLIED WARRANTIES, INCLUDING WARRANTIES OF MERCHANTABILITY AND FITNESS FOR PARTICULAR PURPOSE, ARE LIMITED IN DURATION TO THE LENGTH OF THIS WARRANTY.

## EXCLUSION OF CERTAIN DAMAGES

JBL'S LIABILITY IS LIMITED TO THE REPAIR OR REPLACEMENT, AT OUR OPTION, OF ANY DEFECTIVE PRODUCT AND SHALL NOT INCLUDE INCIDENTAL OR CONSEQUENTIAL DAMAGES OF ANY KIND. SOME STATES DO NOT ALLOW LIMITATIONS ON HOW LONG AN IMPLIED WARRANTY LASTS AND/OR DO NOT ALLOW THE EXCLUSION OF INCIDENTAL OR CONSEQUENTIAL DAMAGES, SO THE ABOVE LIMITATIONS AND EXCLUSIONS MAY NOT APPLY TO YOU. THIS WARRANTY GIVES YOU SPECIFIC LEGAL RIGHTS, AND YOU MAY ALSO HAVE OTHER RIGHTS, WHICH VARY, FROM STATE TO STATE.

## JBL Professional

8500 Balboa Blvd. Northridge, CA 91329 USA

# CONTACT INFORMATION

---



## **Mailing Address:**

JBL Professional  
8500 Balboa Blvd.  
Northridge, CA 91329

## **Shipping Address:**

JBL Professional  
8500 Balboa Blvd., Dock 15  
Northridge, CA 91329

(Do not return product to this address without first obtaining prior authorization from JBL)

## **Customer Service:**

Monday through Friday  
8:00am -5:00pm  
Pacific Coast Time in the U.S.A.

## **(800) 8JBLPRO (800.852.5776)**

[www.jblproservice.com](http://www.jblproservice.com)

## **On The World Wide Web:**

[www.jblpro.com](http://www.jblpro.com)

## **Professional Contacts, Outside the USA:**

Contact the JBL Professional Distributor in your area.

A complete list of JBL Professional international distributors is provided at our U.S.A. website: [www.jblpro.com](http://www.jblpro.com)





# PRX900

SERIES SUBWOOFERS