

0 1 2 3 4 5 6 7 8 9 10 11 12 13 14 15 16 17 18 19 20 21 22 23 24 25 26 27

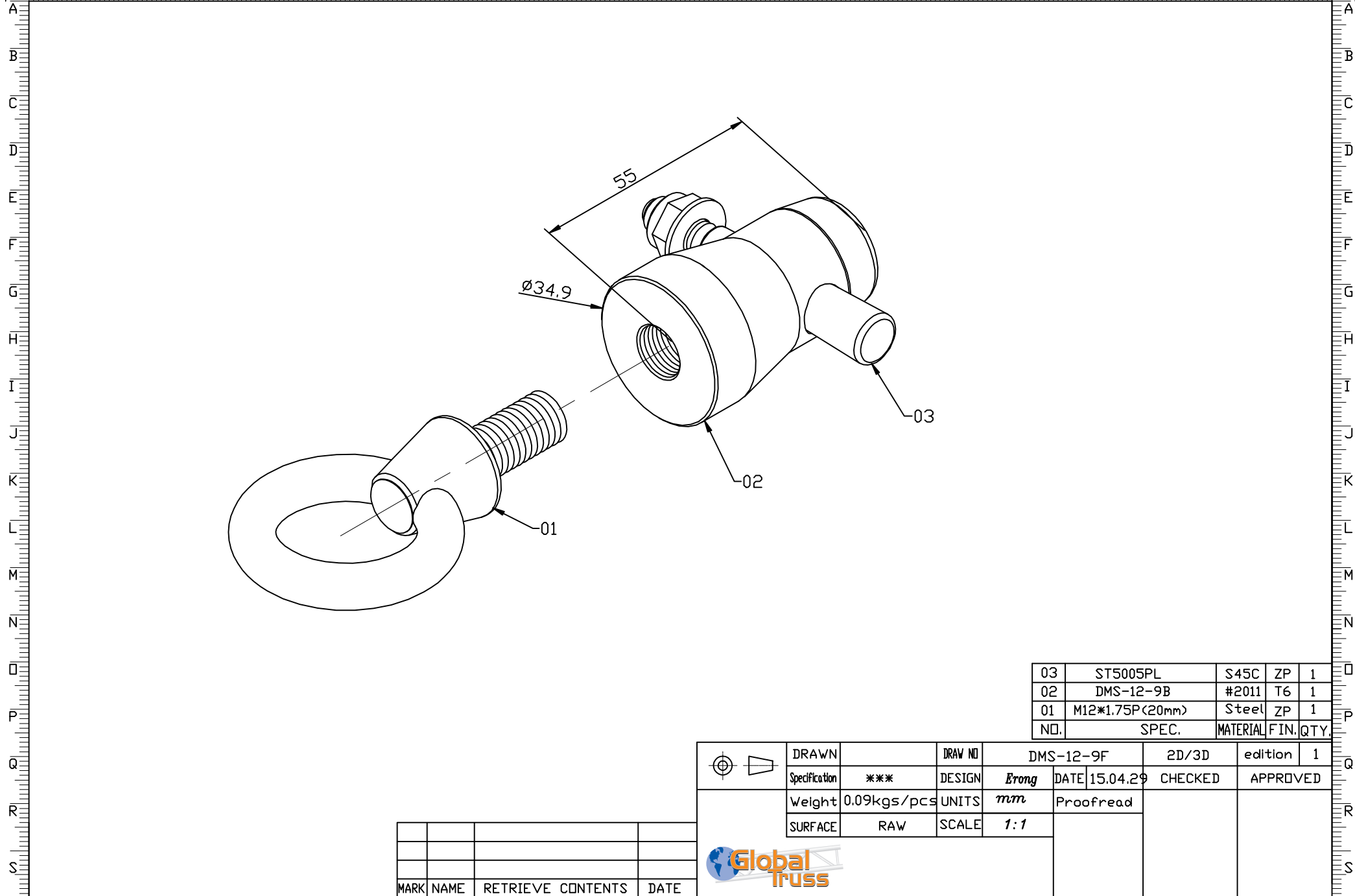

03	ST5005PL	S45C	ZP	1
02	DMS-12-9B	#2011	T6	1
01	M12*1.75P<20mm>	Steel	ZP	1
NO.	SPEC.	MATERIAL	FIN.	QTY.

	DRAWN		DRAW NO	DMS-12-9F	2D/3D	edition	1	
	Specification	***	DESIGN	<i>Erong</i>	DATE	15.04.29	CHECKED	APPROVED
	Weight	0.09kgs/pcs	UNITS	<i>mm</i>	Proofread			
	SURFACE	RAW	SCALE	1:1				

MARK	NAME	RETRIEVE CONTENTS	DATE



0 1 2 3 4 5 6 7 8 9 10 11 12 13 14 15 16 17 18 19 20 21 22 23 24 25 26 27