

APPLICATIONS

- Live sound loudspeaker management
- Active monitor systems
- Fixed applications

FUNCTIONAL FEATURES

- Professional 2-input, 6-output system processor
- Comprehensive processing options including EQ, Gate, Delay, Dynamic EQ
- Fully assignable matrix routing of both inputs to any output
- IIR, FIR and Linear Phase crossover
- RMS and Peak limiter
- Freq/Phase system response measurement with PC and sound card
- Auto EQ routine using IIR, FIR, Linear phase filters and user target curve
- Signal generator Pink/white noise
- One press Mute buttons for all inputs and outputs
- Front panel control with LCD display with an intuitive menu
- Networking option using either Ethernet or RS 485 for larger systems
- Front panel USB port for quick and easy PC connection
- Output channel preset import function
- Six segment Led metering for input and output level and limiter operation
- 3-level customisable user modes with individual password protection
- 32 user Presets to store system configurations

DESCRIPTION

The DLM 260 is a DSP based 2 inputs x 6 output digital loudspeaker management processor, ideally suited for fixed installations and live events. It combines the functions of a multitude of conventional products in a compact 1 U unit with extensive PC remote control capabilities. Routing is freely assignable from the two inputs to the six outputs. Input and output equalisation is available with a choice of 16 filter options. A total of 31 IIR EQ is available for each input, or 13 IIR EQ + FIR; eight IIR EQ for each output or four IIR EQ + FIR is also available. Many options for crossover type include IIR from 6 to 48dB/oct, FIR and Linear Phase with constant group Delay. Input and output delay is available to time align components in a system; RMS and peak limiters will protect your speakers from damage due to excessive power being applied. On input paths, the processing chain sees in cascade: input gain / delay / noise gate / dynamic loudness / filtering section / RMS compressor. On output paths the processing chain sees in cascade: output gain / delay / polarity / filtering section / RMS compressor / peak limiter. The processor features 32 user memory locations to store popular configurations and settings can be exported to a file via the dedicated PC application, either as a back-up to store more favourite configurations if the 32 on-board presets are not sufficient. A very useful function is the ability to recall entire output channel configurations. PC connectivity is available via a front panel USB port but for larger systems with several processors can use Ethernet or RS 485 network connections.

OVERVIEW OF SIGNAL PROCESSING

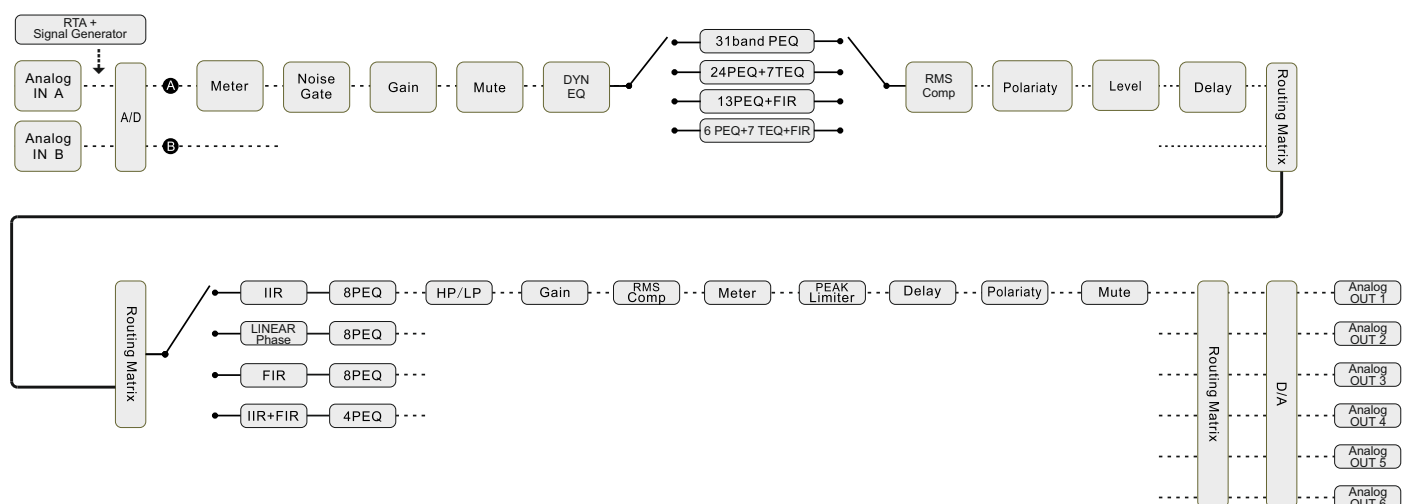

CONTROL & FUNCTIONS

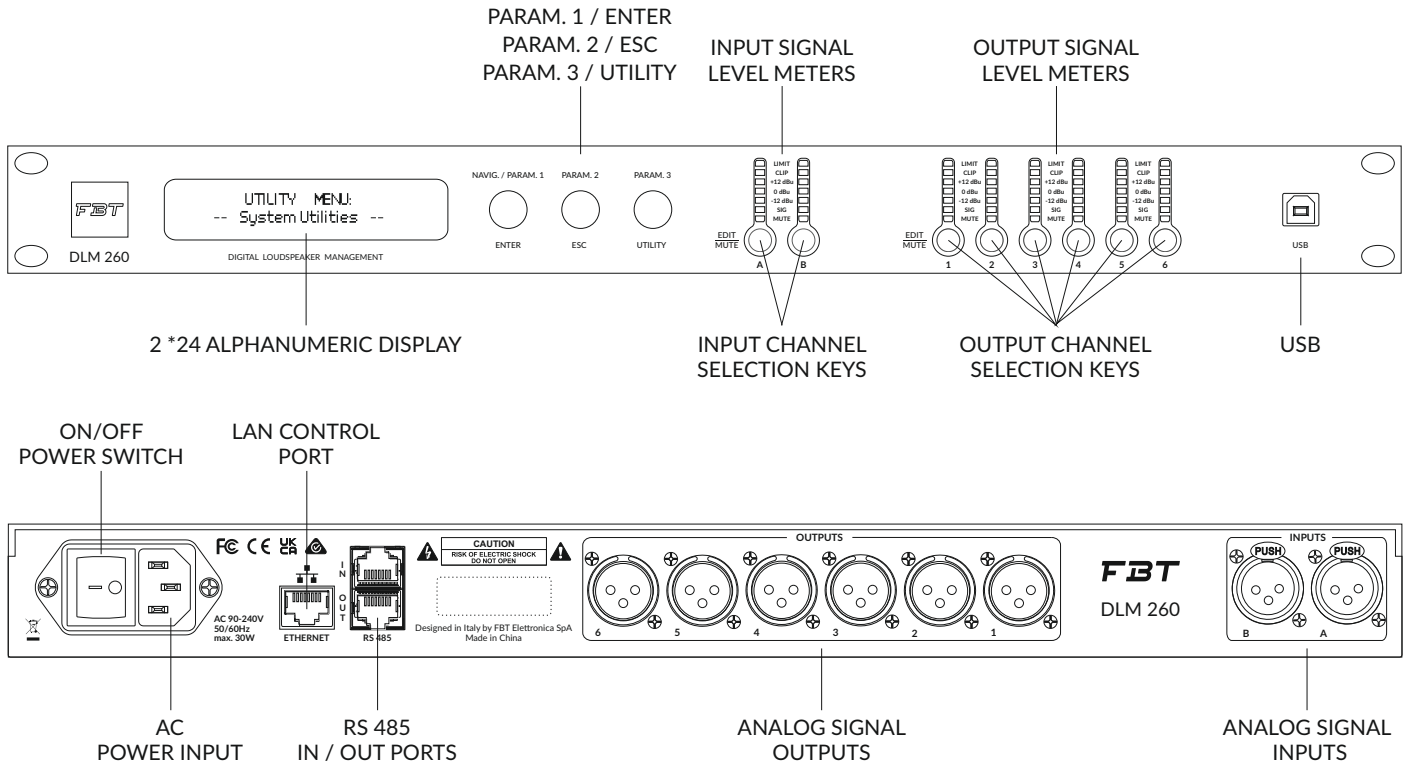

DIMENSIONS

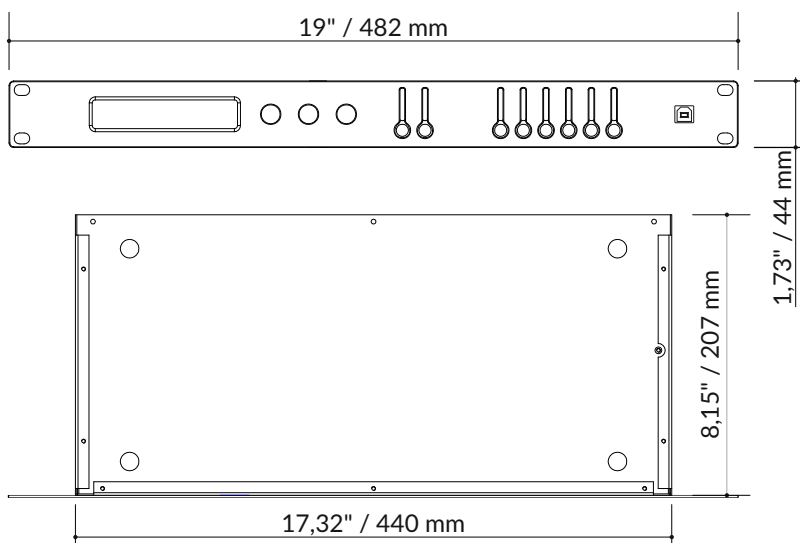

TECHNICAL SPECIFICATIONS

GENERAL

Input Impedance	20K Ohm balanced
Output Impedance	100 Ohm
Max. Input Level	+20dBu
Max. Output Level	+18dBu
Crosstalk	< -95dB
Sample Rate	48kHz
Signal to Noise Ratio	> 116dB (A weighted)
Noise Floor	< -95dB (A weighted)
Common Mode Rejection Ratio	60dB
Frequency Response	20Hz - 20kHz +0.3dB
THD (+4dBu 1kHz)	< 0.003%
Mains Voltage Range	90 - 240Vac / 50-60Hz
Nominal Power Consumption	30W

CONNECTORS

Audio Input	2 x 3 pin female XLR
Audio Output	6 x 3 pin male XLR
Ethernet	shielded RJ45, Dynamic or Static IP
RS485	2 x RJ45
USB	1 x USB "B"
Mains	3 pin IEC

PHYSICAL

Height	1U (44mm) (1.75")
Width	482mm (19")
Depth	230mm (9.1")
Weight	3.0kg (6.6 lb)

PROCESSING

Signal Generator	White/Pink noise - Level range: -30dBu +10dBu
Input & Output Gain	-18dB +12dB, step 0.1dB
Noise Gate	Threshold: -80dBu -45dBu Attack time: 1ms 1000ms Release time: 1ms 1000ms
Dynamic Loudness Filter	Gain range: 0dB -10dB Attack speed: fast/medium/slow
Parametric EQ	Input channels up to 31 optional types of EQ Output channels up to 8 optional types of EQ
Optional Filter types	Bell classic and constant Q filter, 1st order high Shelf filter, 2nd order high Shelf filter, Variable Q high Shelf filter, 1st order low Shelf filter, 2nd order low Shelf filter, Variable Q low Shelf filter, 1st order low-pass filter, 2nd order low-pass filter, Variable Q low-pass filter, 1st order high-pass filter, 2nd order high-pass filter, Variable Q high-pass filter, Band pass filter, notch filter, 1st order all-pass filter, 2nd order all-pass filter with variable Q value
Center Frequency	Adjustable within the frequency range of 20Hz-20kHz with a step accuracy of 1Hz
Q value / Bandwidth	The Q value range of Bell filter is 0.4 - 128, the step is 0.01, the range of the Q value of the Chevron/highpass/lowpass filter is 0.1 - 5.1 and the step is 0.01, the value range of bandpass /notch filter Q is 4 - 104 and step is 1
EQ Gain range	-15dB +15dB
IIR Crossover Filter	Butterworth slope: 6/12/18/24/36/48dB per octave, Bessel slope: 12/24dB per octave, Linkwitz-Riley slope: 12/24/36/48dB per octave
Linear Phase Filter	Linkwitz-Riley: 24/48dB per octave
FIR Crossover Filter	Type: high pass/low pass/band pass/external import Taps range: 256 - 512, slope range 21 - 120dB per octave Time window type: Rect/Sinc/Keiser/Hanning/Hamming/Blackman/Blackman-Harris/Blackman-Nuttall/Nuttall/Keiser-Bessel/Sine
RMS Compressor	Starting threshold range: -10dBu +20dBu Compression ratio range: 2 - 32:1 Soft and hard knee: 0 - 100% Attack time: 0.1ms - 1000ms Release time: 10ms - 15000ms Gain compensation: Max 12dB
Peak Limiter	Threshold range: -10dBu +20dBu Attack time: 1ms - 1000ms Release time: 10ms - 3000ms
Delay	The adjustable delay time of each input channel + output channel is 452ms, step accuracy 0.0104ms
FIR Filter	Each input channel and output channel can import FIR filter with 48kHz sampling rate and 512 taps

SOFTWARE MAIN INTERFACE

