

# **EQUINOX**

## **Microbar Multi System**

**User Manual**



**Order code: EQLED136**

### WARNING

## FOR YOUR OWN SAFETY, PLEASE READ THIS USER MANUAL CAREFULLY BEFORE YOUR INITIAL START-UP!

- Before your initial start-up, please make sure that there is no damage caused during transportation.
- Should there be any damage, consult your dealer and do not use the equipment.
- To maintain the equipment in good working condition and to ensure safe operation, it is necessary for the user to follow the safety instructions and warning notes written in this manual.
- Please note that damages caused by user modifications to this equipment are not subject to warranty.



### IMPORTANT:

The manufacturer will not accept liability for any resulting damages caused by the non-observance of this manual or any unauthorised modification to the equipment.

- Never let the power cable come into contact with other cables. Handle the power cable and all mains voltage connections with particular caution!
- Never remove warning or informative labels from the unit.
- Do not open the equipment and do not modify the unit.
- Do not connect this equipment to a dimmer pack.
- Do not switch the equipment on and off in short intervals, as this will reduce the system's life.
- Only use the equipment indoors.
- Do not expose to flammable sources, liquids or gases.
- Always disconnect the power from the mains when equipment is not in use or before cleaning! Only handle the power-cable by the plug. Never pull out the plug by pulling the power-cable.
- Make sure that the available mains supply voltage is between 100~240V AC, 50/60Hz.
- Make sure that the power cable is never crimped or damaged. Check the equipment and the power cable periodically.
- If the equipment is dropped or damaged, disconnect the mains power supply immediately and have a qualified engineer inspect the equipment before operating again.
- This unit is not intended for fixed installation.
- If the equipment has been exposed to drastic temperature fluctuation (e.g. after transportation), do not connect power or switch it on immediately. The arising condensation might damage the equipment. Leave the equipment switched off until it has reached room temperature.
- If your product fails to function correctly, stop use immediately. Pack the unit securely (preferably in the original packing material), and return it to your Pro Light dealer for service.
- Only use fuses of same type and rating.
- Repairs, servicing and power connection must only be carried out by a qualified technician. THIS UNIT CONTAINS NO USER SERVICEABLE PARTS.
- This lighting fixture is for professional use only - it is not designed for or suitable for household use. The product must be installed by a qualified technician in accordance with local territory regulations. The safety of the installation is the responsibility of the installer. The fixture presents risks of severe injury or death due to fire hazards, electric shock and falls.
- Warning! Risk Group 2 LED product according to EN 62471. Do not view the light output with optical instruments or any device that may concentrate the beam.
- WARRANTY: One year from date of purchase.

### OPERATING DETERMINATIONS

If this equipment is operated in any other way, than those described in this manual, the product may suffer damage and the warranty becomes void. Incorrect operation may lead to danger e.g: short-circuit, burns and electric shocks etc.

Do not endanger your own safety and the safety of others!

Incorrect installation or use can cause serious damage to people and/or property.

### Microbar Multi System

A compact, all-in-one lighting package, the Equinox Microbar Multi System includes a robust, heavy duty stand, heavy duty road bag, IR remote, 2 multi-colour LED Par panels and 2 light effects fitted to a powered T-bar. The 4 LED units are of a micro size and lightweight design. The user has control over colour, auto, sound active and DMX modes, via the LED display and push buttons. The IR remote gives instant and simple control over several control modes: blackout, auto, sound and colour.

- - 2 pars each containing 12 x 1W LEDs (R: 3, G: 3, B: 3, W: 3) plus 1 derby containing 4 x 3W LEDs (R: 1, G: 1, B: 1, W: 1) and 1 moonflower containing 1 x 10W quad-colour LED (RGBW)
- Beam angle: 25° (pars)
- DMX channels: 3/6 or 15 selectable
- Auto, sound active and master/slave modes plus built-in programs
- 0-100% dimming and variable strobe
- 4 push button menu with LED display
- 3-Pin XLR input/output
- IEC power input
- IR remote control
- Height adjustable stand
- Carry bag included



Specifications	
Power consumption	55W
Power supply	100~240V, 50/60Hz
Fuse	F3A 250V
Dimensions (without stand)	200 x 750 x 165mm
Weight	5.7kg
Order code	EQLED136

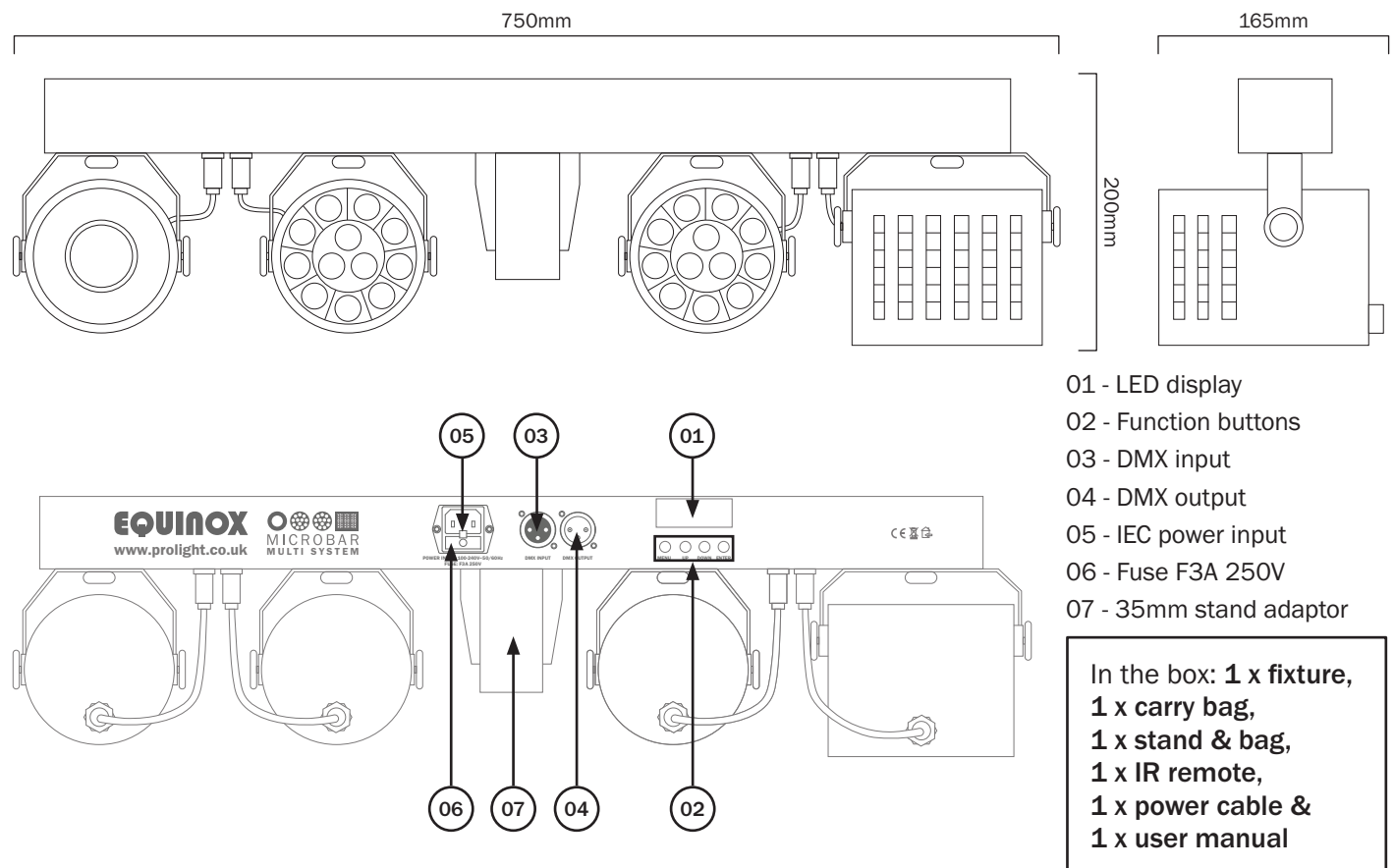

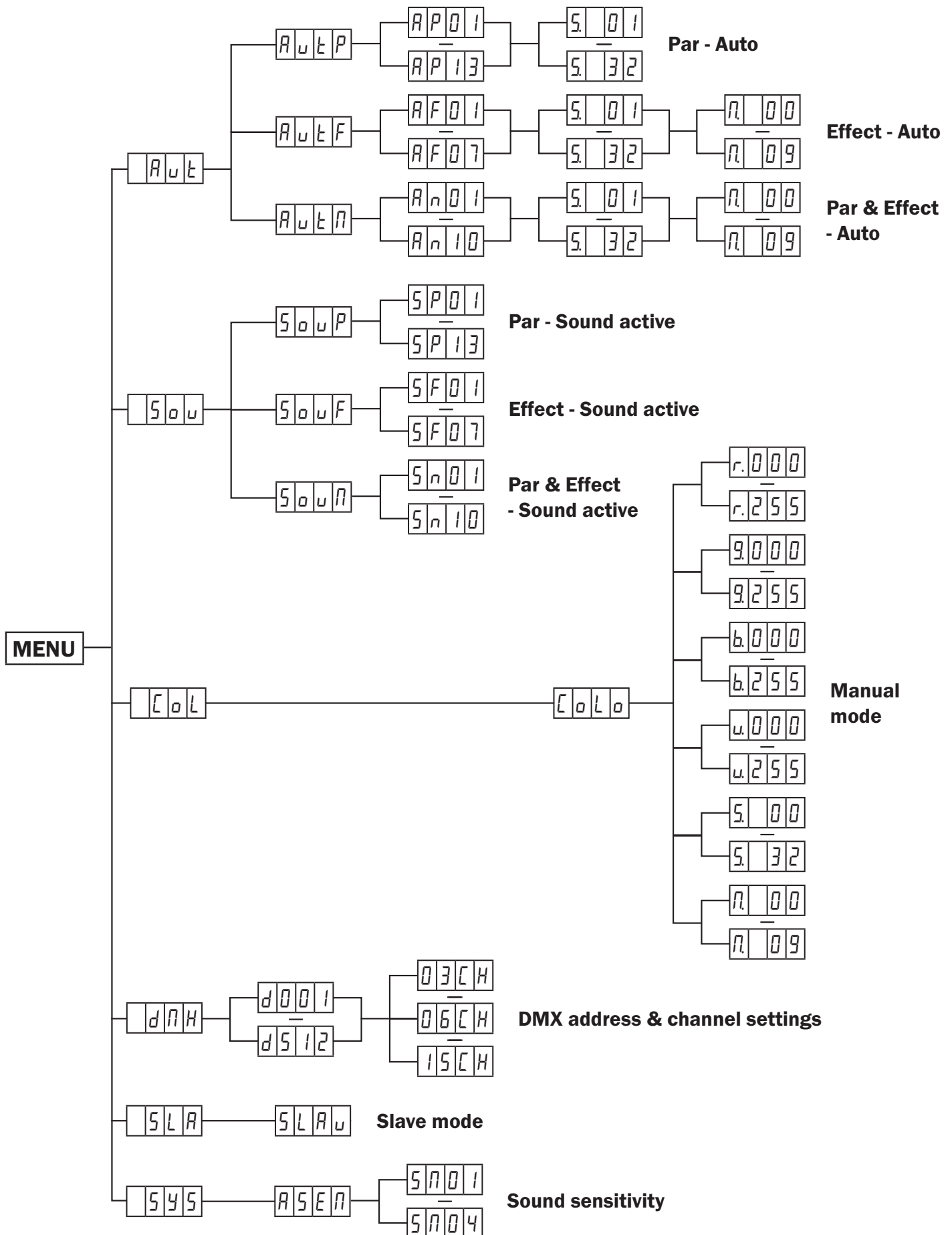

### DMX mode:

Operating in a DMX control mode environment gives the user the greatest flexibility when it comes to customising or creating a show. In this mode you will be able to control each individual trait of the fixture and each fixture independently.

To access the DMX address mode, press the “**MENU**” button on the rear of the unit to show *dH* on the LED display. Now press the “**ENTER**” button and use the “**UP**” and “**DOWN**” buttons to set the required DMX address. Press the “**ENTER**” button to confirm the setting. Now use the “**UP**” and “**DOWN**” buttons to choose one of the 3/6 or 15 DMX channel modes. Press the “**ENTER**” button to confirm the setting.

To exit out of any of the above options, press the “**MENU**” button.

### 3 channel mode:

Channel	Value	Function
CH1	000-009	No function
	010-049	APXX - Par auto
	050-089	AFX - Effect auto
	090-129	ANXX - Par & Effect auto
	130-169	SPXX - Par sound active
	170-209	SFXX - Effect sound active
	210-255	SNXX - Par & Effect sound active
	CH2	000-019
020-039		AP02/SP02
040-059		AP03/SP03
060-079		AP04/SP04
080-099		AP05/SP05
100-119		AP06/SP06
120-139		AP07/SP07
140-159		AP08/SP08
160-179		AP09/SP09
180-199		AP10/SP10
200-219		AP11/SP11
220-239		AP12/SP12
240-255		AP13/SP13

CH2	020-039	AF02/SF02	When CH1 is 050-089 or 170-209
	040-059	AF03/SF03	
	060-079	AF04/SF04	
	080-099	AF05/SF05	
	100-119	AF06/SF06	
	120-255	AF07/SF07	
CH2	000-019	AN01/SN01	When CH1 is 090-129 or 210-255
	020-039	AN02/SN02	
	040-059	AN03/SN03	
	060-079	AN04/SN04	
	080-099	AN05/SN05	
	100-119	AN06/SN06	
	120-139	AN07/SN07	
	140-159	AN08/SN08	
	160-179	AN09/SN09	
	180-255	AN10/SN10	
CH3	000-255	Speed adjustment	

### 6 channel mode:

Channel	Value	Function
CH1	000-255	Red (0-100%)
CH2	000-255	Green (0-100%)
CH3	000-255	Blue (0-100%)
CH4	000-255	White (0-100%)
CH5	000-255	Strobe (slow-fast)
CH6	000-255	Motor speed (slow-fast)

### 15 channel mode:

Channel	Value	Function	
CH1	000-255	Red (0-100%)	Effect 1
CH2	000-255	Green (0-100%)	
CH3	000-255	Blue (0-100%)	
CH4	000-255	White (0-100%)	
CH5	000-255	Motor	
CH6	000-255	Red (0-100%)	Pars 1 & 2
CH7	000-255	Green (0-100%)	
CH8	000-255	Blue (0-100%)	
CH9	000-255	White (0-100%)	Effect 2
CH10	000-255	Red (0-100%)	
CH11	000-255	Green (0-100%)	
CH12	000-255	Blue (0-100%)	
CH13	000-255	White (0-100%)	
CH14	000-255	Motor	
CH15	000-255	Strobe	

### Master/slave mode:

To set the unit in slave mode, press the “MENU” button on the rear of the unit to show *SLA* on the LED display. Now press the “ENTER” button to display *SLA*. Press the “ENTER” button to confirm the setting. The unit will now run in sequence with the master unit.

To exit out of any of the above options, press the “MENU” button.

Please ensure that all slave units are set to the same DMX channel mode as the master unit.

### Auto mode:

To access the auto modes, press the “MENU” button on the rear of the unit to show *Auto* on the LED display. Now press the “ENTER” button and use the “UP” and “DOWN” buttons to choose between *AutoP* (Par - Auto), *AutoF* (Effect - Auto) or *AutoE* (Par & Effect - Auto). Press the “ENTER” button to confirm the setting and use the “UP” and “DOWN” buttons to choose the auto program between *AP01 ~ AP13* (Par - Auto), *AF01 ~ AF07* (Effect - Auto) or *AE01 ~ AE10* (Par & Effect - Auto). Now press the “ENTER” button and use the “UP” and “DOWN” buttons to select the program speed between *5.00 ~ 5.32*. Finally press the “ENTER” button and use the “UP” and “DOWN” buttons to select the motor speed between *0.00 ~ 0.09*. (The motor speed can only be selected when in *AutoF* (Effect - Auto) or *AutoE* (Par & Effect Auto) modes).

Press the “ENTER” button to confirm the setting.

To exit out of any of the above options, press the “MENU” button.

## Sound/sound sensitivity:

To access the sound modes, press the “MENU” button on the rear of the unit to show *SOU* on the LED display. Now press the “ENTER” button and use the “UP” and “DOWN” buttons to choose between *SouP* (Par - Sound active), *SouF* (Effect - Sound active) or *SouN* (Par & Effect - Sound active). Press the “ENTER” button to confirm the setting and use the “UP” and “DOWN” buttons to choose the sound program between *SP01 ~ SP13* (Par - Sound active), *SF01 ~ SF07* (Effect - Sound active) or *SN01 ~ SN10* (Par & Effect - Sound active).

Press the “ENTER” button to confirm the setting.

To exit out of any of the above options, press the “MENU” button.

To adjust the sound sensitivity, press the “MENU” button on the rear of the unit to show *SY5* on the LED display. Now press the “ENTER” button to display *ASEN*. Press the “ENTER” button and use the “UP” and “DOWN” buttons to choose between *SN01 ~ SN04*.

Press the “ENTER” button to confirm the setting.

To exit out of any of the above options, press the “MENU” button.

## Manual mode:

To access manual mode, press the “MENU” button on the rear of the unit to show *COL* on the LED display. Now press the “ENTER” button to display *COL0*. Now press the “ENTER” button and use the “UP” and “DOWN” buttons to choose between *r.000 ~ r.255* (Red). Repeat for *G* (Green), *b* (Blue) and *U* (White). Press the “ENTER” button to confirm the setting and use the “UP” and “DOWN” buttons to choose the strobe speed between *S. 00 ~ S. 32*. Finally press the “ENTER” button to confirm the setting and use the “UP” and “DOWN” buttons to choose the motor speed between *n. 00 ~ n. 09*.

To exit out of any of the above options, press the “MENU” button.

### IR remote functions:

#### Button functions:

- 01 - Sets the unit into blackout on or off
  - 02 - Puts the unit into DMX mode - Press the button once for 3 channel, press twice for 6 channel modes.
  - 03 - Runs the Par & Effects auto show mode
  - 04 - Runs the Par auto show mode
  - 05 - Runs the Effect auto show mode
  - 06 - Par & Effects sound active mode
  - 07 - Runs the Par sound active mode
  - 08 - Runs the Effect sound active mode
  - 09 - Runs colour change (pars only) - Use 'par colour' to adjust speed
  - 10 - Runs colour fade (pars only) - Use 'par colour' to adjust speed
  - 11 - Runs strobe (pars only) - Use 'par colour' to adjust speed
  - 12 - Sets the run speed - Use the '+' and '-' buttons to change the desired speed (note: only available in the auto shows, colour change, colour fade and strobe modes)
- Sets the motor speed for the effects motor rotation  
- Use the '+' and '-' buttons to change the desired speed
- 13 - Sets the sound sensitivity - Use the '+' and '-' buttons to set the desired sensitivity (1-4)

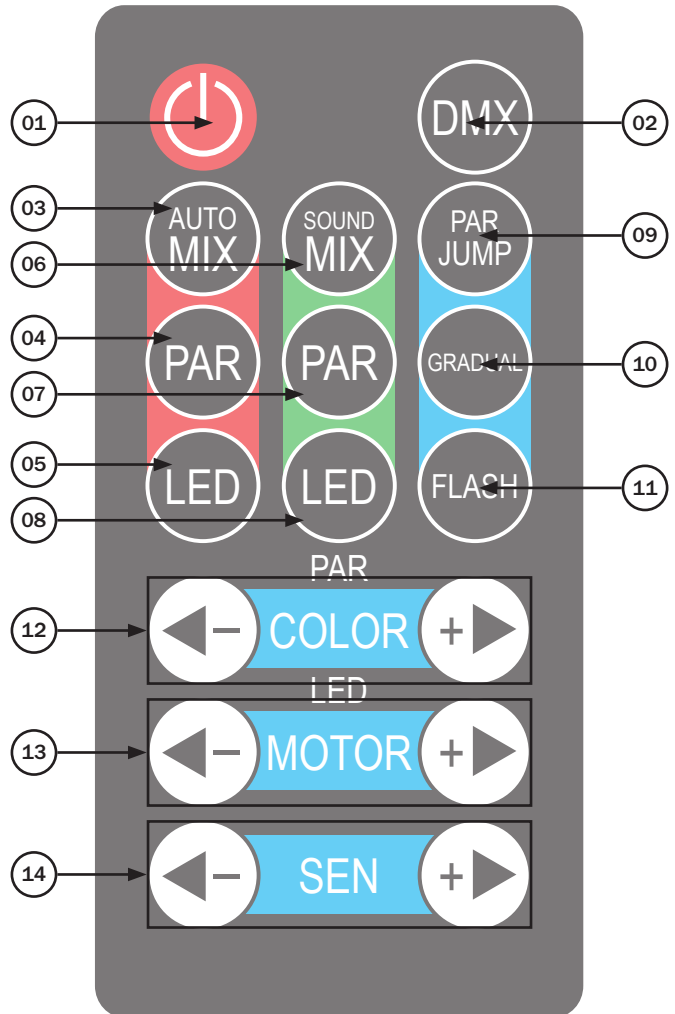



### Setting the DMX address:

The DMX mode enables the use of a universal DMX controller. Each fixture requires a “start address” from 1- 512. A fixture requiring one or more channels for control begins to read the data on the channel indicated by the start address. For example, a fixture that occupies or uses 7 channels of DMX and was addressed to start on DMX channel 100, would read data from channels: 100,101,102,103,104,105 and 106. Choose a start address so that the channels used do not overlap. E.g. the next unit in the chain starts at 107.

### DMX 512:

DMX (Digital Multiplex) is a universal protocol used as a form of communication between intelligent fixtures and controllers. A DMX controller sends DMX data instructions from the controller to the fixture. DMX data is sent as serial data that travels from fixture to fixture via the DATA “IN” and DATA “OUT” XLR terminals located on all DMX fixtures (most controllers only have a data “out” terminal).

### DMX linking:

DMX is a language allowing all makes and models of different manufactures to be linked together and operate from a single controller, as long as all fixtures and the controller are DMX compliant. To ensure proper DMX data transmission, when using several DMX fixtures try to use the shortest cable path possible. The order in which fixtures are connected in a DMX line does not influence the DMX addressing. For example; a fixture assigned to a DMX address of 1 may be placed anywhere in a DMX line, at the beginning, at the end, or anywhere in the middle. When a fixture is assigned a DMX address of 1, the DMX controller knows to send DATA assigned to address 1 to that unit, no matter where it is located in the DMX chain.

### DATA cable (DMX cable) requirements (for DMX operation):

This fixture can be controlled via DMX-512 protocol. The DMX address is set on the back of the unit. Your unit and your DMX controller require a standard 3-pin XLR connector for data input/output, see image below.



Further DMX cables can be purchased from all good sound and lighting suppliers or Pro Light Concepts dealers.

Please quote:

**CABL10 – 2m**

**CABL11 – 5m**

**CABL12 – 10m**

Also remember that DMX cable must be daisy chained and cannot be split.

**Notice:**

Be sure to follow the diagrams below when making your own cables. Do not connect the cables shield conductor to the ground lug or allow the shield conductor to come in contact with the XLRs outer casing. Grounding the shield could cause a short circuit and erratic behaviour.

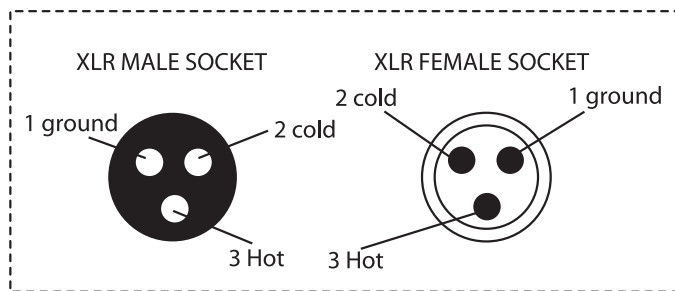
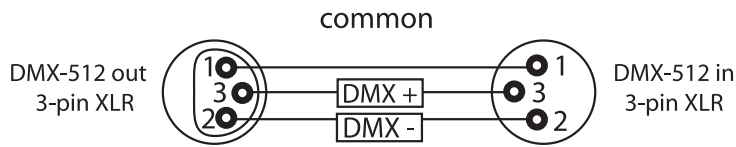

XLR Pin Configuration
Pin 1 = Ground
Pin 2 = Negative
Pin 3 = Postive

**Special note:**

**Line termination:**

When longer runs of cable are used, you may need to use a terminator on the last unit to avoid erratic behaviour.

**Using a cable terminator will decrease the possibilities of erratic behaviour.**

**(3-pin - Order ref: CABL90, 5-pin - Order ref: CABL89)**

Termination reduces signal transmission problems and interference. it is always advisable to connect a DMX terminal, (resistance 120 Ohm 1/4 W) between pin 2 (DMX-) and pin 3 (DMX+) of the last fixture.

**5-pin XLR DMX connectors:**

Some manufactures use 5-pin XLR connectors for data transmission in place of 3-pin. 5-pin XLR fixtures may be implemented in a 3-pin XLR DMX line. When inserting standard 5-pin XLR connectors in to a 3-pin line a cable adaptor must be used. The diagram below details the correct cable conversion.

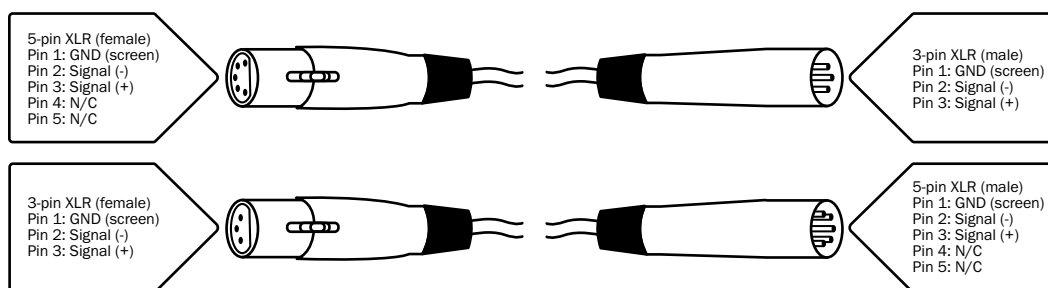



### ***Correct Disposal of this Product (Waste Electrical & Electronic Equipment)***

**(Applicable in the European Union and other European countries  
with separate collection systems)**

This marking shown on the product or its literature, indicates that it should not be disposed of with other household wastes at the end of its working life. To prevent possible harm to the environment or human health from uncontrolled waste disposal, please separate this from other types of wastes and recycle it responsibly to promote the sustainable reuse of material resources.

Household users should contact either the retailer where they purchased this product, or their local government office, for details of where and how they can take this item for environmentally safe recycling.

Business users should contact their supplier and check the terms and conditions of the purchase contract. This product should not be mixed with other commercial wastes for disposal.



# EQUINOX