

# elumen8

## **Virtuoso 1000 Profile RGBAL** User Manual



**Order codes: ELUM132**

### WARNING

## FOR YOUR OWN SAFETY, PLEASE READ THIS USER MANUAL CAREFULLY BEFORE YOUR INITIAL START-UP!

- Before your initial start-up, please make sure that there is no damage caused during transportation.
- Should there be any damage, consult your dealer and do not use the equipment.
- To maintain the equipment in good working condition and to ensure safe operation, it is necessary for the user to follow the safety instructions and warning notes written in this manual.
- Please note that damages caused by user modifications to this equipment are not subject to warranty.



### IMPORTANT:

The manufacturer will not accept liability for any resulting damages caused by the non-observance of this manual or any unauthorised modification to the equipment.

- Never let the power cable come into contact with other cables. Handle the power cable and all mains voltage connections with particular caution!
- Never remove warning or informative labels from the unit.
- Do not open the equipment and do not modify the unit.
- Do not connect this equipment to a dimmer pack.
- Do not switch the equipment on and off in short intervals, as this will reduce the system's life.
- Only use the equipment indoors.
- Do not expose to flammable sources, liquids or gases.
- Always disconnect the power from the mains when equipment is not in use or before cleaning! Only handle the power-cable by the plug. Never pull out the plug by pulling the power-cable.
- Make sure that the available mains supply voltage is between 100~240V AC, 50/60Hz.
- Make sure that the power cable is never crimped or damaged. Check the equipment and the power cable periodically.
- If the equipment has been exposed to drastic temperature fluctuation (e.g. after transportation), do not connect power or switch it on immediately. The arising condensation might damage the equipment. Leave the equipment switched off until it has reached room temperature.
- Never touch the fixture during operation as it may be hot.
- If the equipment is dropped or damaged, disconnect the mains power supply immediately and have a qualified engineer inspect the equipment before operating again.
- If your product fails to function correctly, stop use immediately. Pack the unit securely (preferably in the original packing material), and return it to your Pro Light dealer for service.
- Only use fuses of same type and rating.
- Repairs, servicing and power connection must only be carried out by a qualified technician. THIS UNIT CONTAINS NO USER SERVICEABLE PARTS.
- This lighting fixture is for professional use only - it is not designed for or suitable for household use. The product must be installed by a qualified technician in accordance with local territory regulations. The safety of the installation is the responsibility of the installer. The fixture presents risks of severe injury or death due to fire hazards, electric shock and falls.
- Warning! Risk Group 2 LED product according to EN 62471. Do not view the light output with optical instruments or any device that may concentrate the beam.
- WARRANTY: Two years from date of purchase.

### OPERATING DETERMINATIONS

If this equipment is operated in any other way, than those described in this manual, the product may suffer damage and the warranty becomes void. Incorrect operation may lead to danger e.g: short-circuit, burns and electric shocks etc.

Do not endanger your own safety and the safety of others!

Incorrect installation or use can cause serious damage to people and/or property.

### Virtuoso 1000 Profile RGBAL

The Virtuoso 1000 Profile features an advanced RGBAL LED system that outputs a flat and even field and is suitable for many applications. HSIC colour management allows you to create virtually any colour whilst the virtual colour wheel provides direct access to many colours along with a 2700K to 8000K colour temperature control. On board features include DMX, RDM and adjustable PWM rate. Due to the design of the body many common and aftermarket lens tubes can fit directly onto the fixture allowing you to upgrade to LED without having to replace your existing lens tubes.

- 1 x 250W five-colour COB LED (RGBAL)
- Beam angle: 15° - 50° dependent on lens used
- 23,031 Lux @ 2m (full on, 19° lens)
- CRI ≥ 90
- Colour temperature: 2700K-8000K
- Refresh rate: 600Hz, 1.2kHz, 2kHz, 2.4kHz, 6kHz or 25kHz selectable
- Beam framing shutters
- DMX channels: 6/7/8/11 or 17 selectable
- RDM (Remote Device Management)
- 0 - 100% 8 or 16 bit dimming and variable strobe
- 4 dimming curves: Linear, square law, inverse square law and S-curve
- 4 push button menu with LCD display
- PowerCON input/output
- 5-Pin XLR input/output
- 3-Pin XLR input/output
- Temperature controlled fan for whisper quiet operation
- Handle on rear panel



Specifications	Virtuoso 1000 Profile RGBAL
Power consumption	305W
Fuse	T6.3A 250V
Power supply	100~240V, 50/60Hz
Dimensions	520 x 310 x 540mm
Weight	8.3kg
Order code	ELUM132

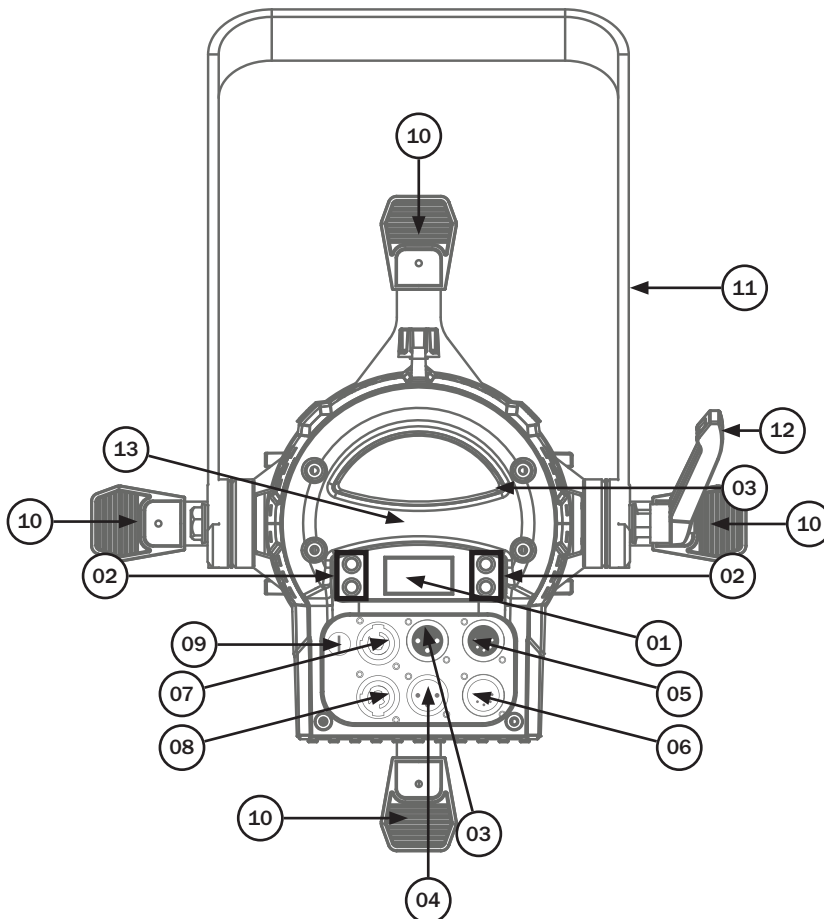
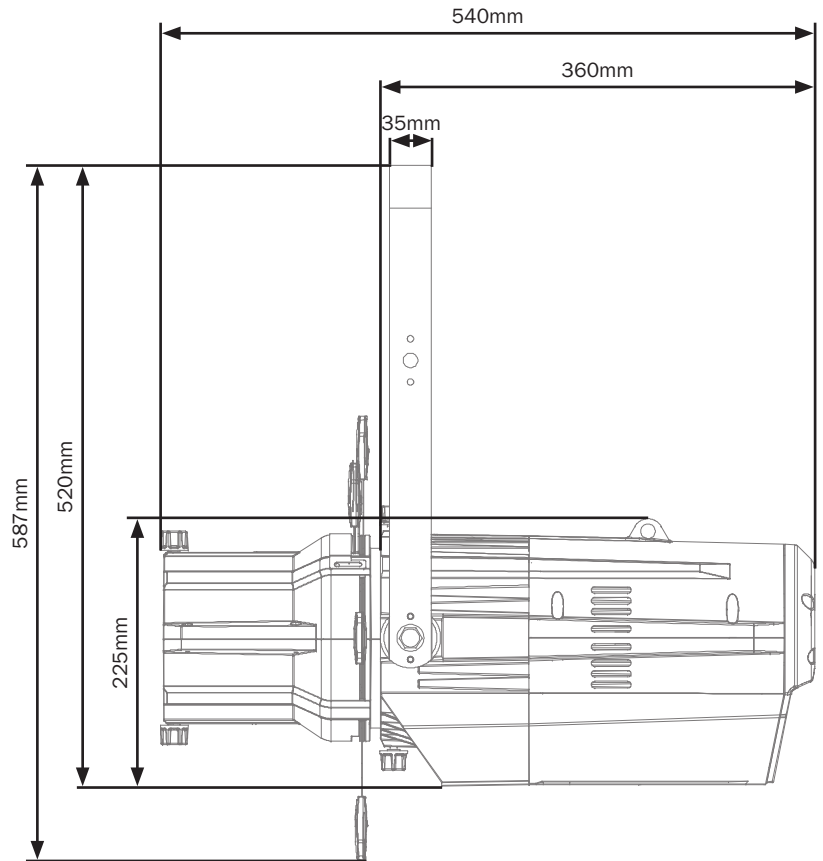
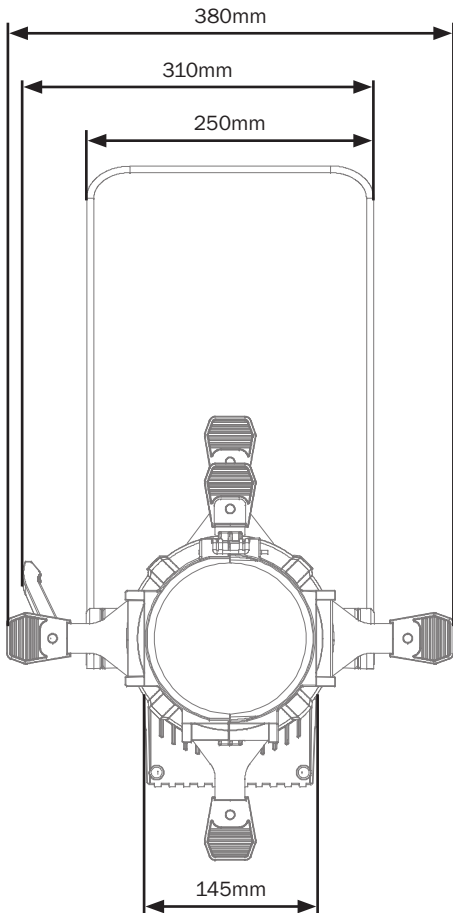

- 01 - LCD display
- 02 - Function buttons
- 03 - 3-Pin DMX input
- 04 - 3-Pin DMX output
- 05 - 5-Pin DMX input
- 06 - 5-Pin DMX output
- 07 - PowerCON input
- 08 - PowerCON output
- 09 - Fuse T6.3A 250V
- 10 - Shutters
- 11 - Hanging bracket
- 12 - Hanging bracket adjustment knob
- 13 - Carry handle

In the box: **1 x fixture,**  
**1 x power cable**  
**& 1 x user manual**

Before installing the fixture, the supporting structure (ie. truss) must be able to hold a minimum of 10 times the fixtures weight without any deformation (eg. 15kg - 150kg point load). The fixture must be secured with a secondary safety attachment when being installed (ie. an appropriate safety cable). Never stand directly below the fixture when mounting, removing, and/or servicing.

Overhead installation requires experience and qualifications to calculate working load limits, the material being used at the installation area and periodic safety inspections of the fixture and installation material. If you do not have the relevant experience and/or qualifications please do not attempt the installation yourself. The installation should be checked annually by a qualified person.

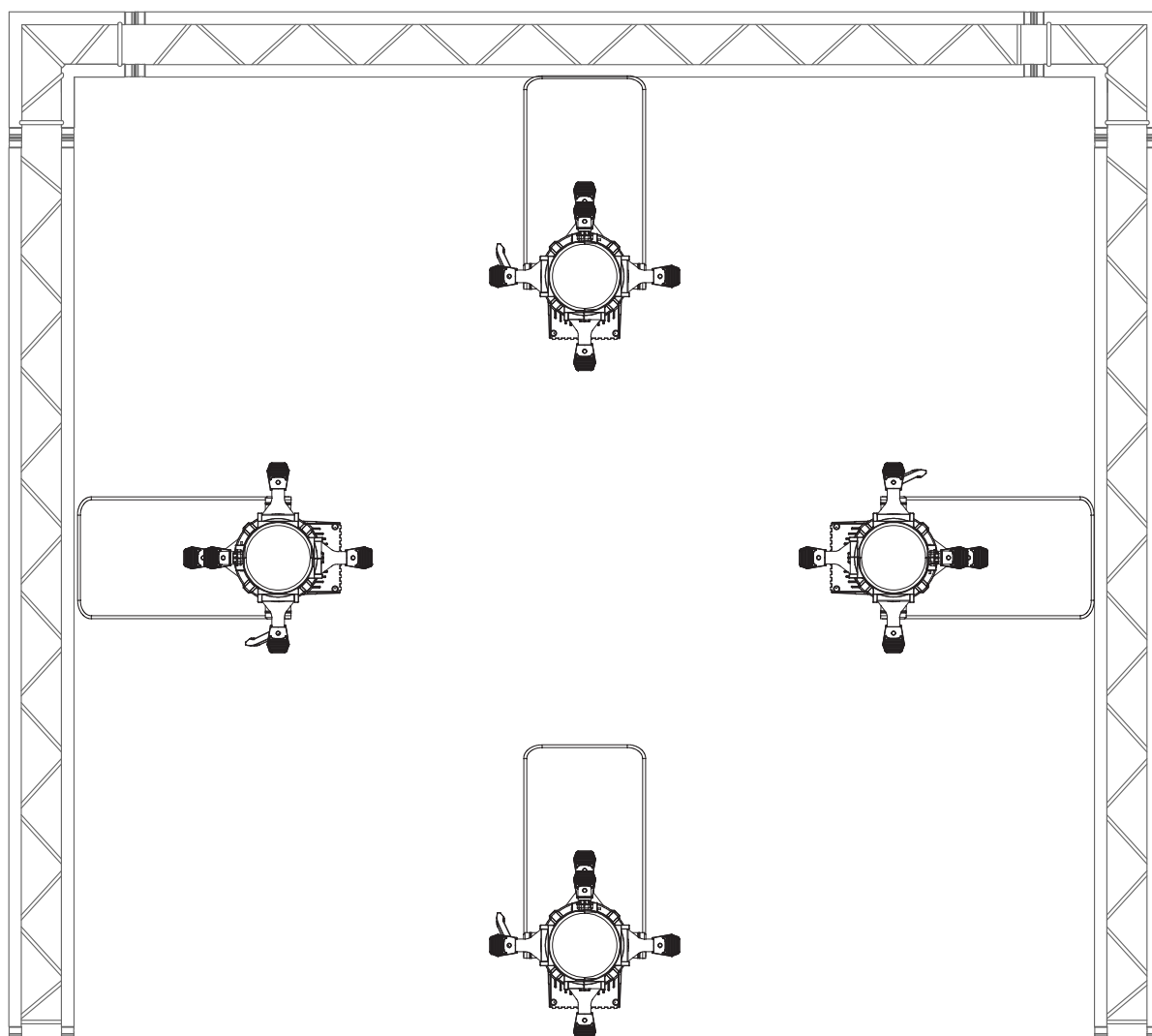

The eLumen8 Virtuoso 1000 Profile RGBAL can be operated in a number of mounting positions as shown in the diagram above, hanging upside-down from the ceiling or truss, mounting sideways on truss or stood upright on a flat level surface. Always use a safety wire as an extra safety precaution to prevent damage/injury in the event a clamp fails (see the next page for clamp installation).

Never use the carry handles for secondary attachments.

### Installation:

1. Fasten the clamp to the fixtures bracket with a bolt and lock nut through one of the mounting holes.
2. Mount the fixture onto your truss system via the clamp and tighten to ensure secure.
3. Pull the safety cable through the fixture bracket and around the truss.

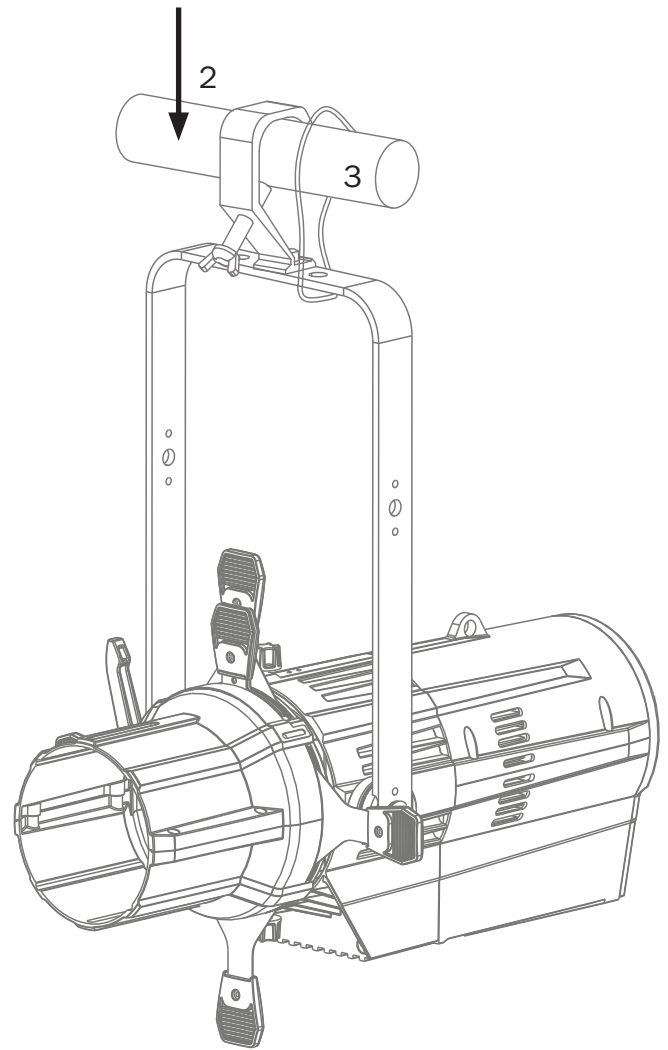
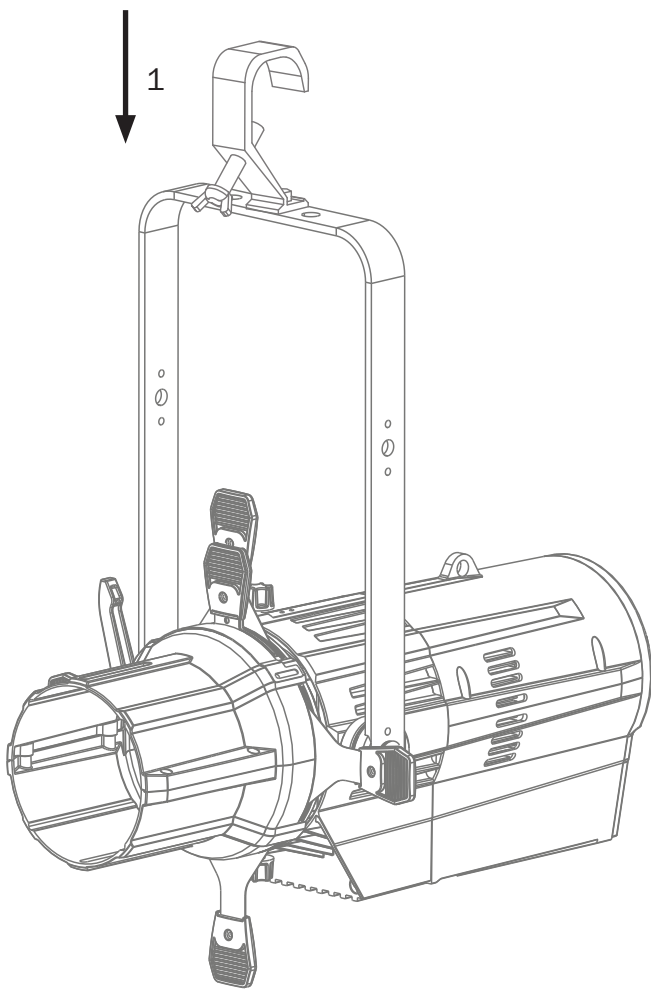

### Beam Focus:

1. Loosen the beam focus knobs located at the top and bottom of the barrel.
2. Slide the lens tube forward or backward until you achieve the desired focus.
3. Once the fixture is focussed, tighten the beam focus knobs.

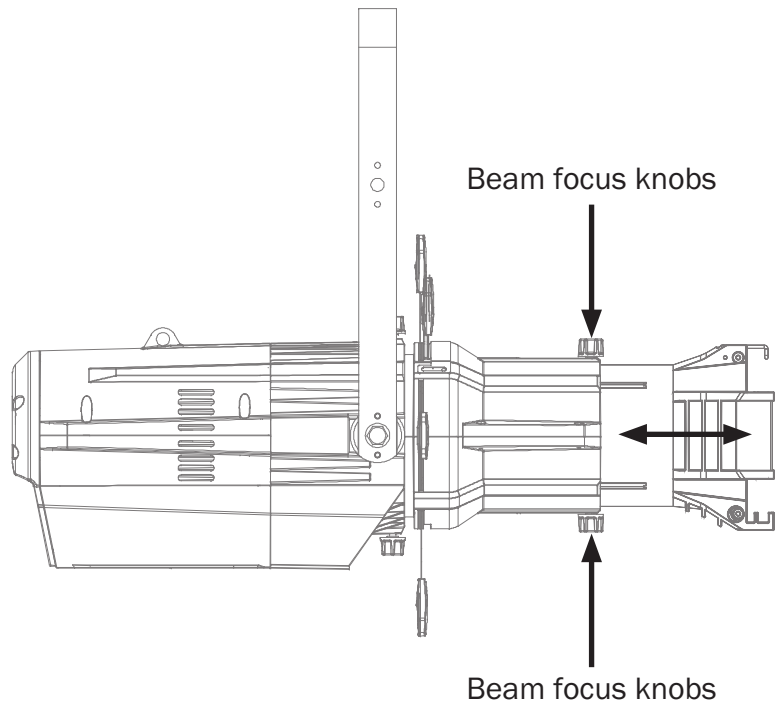

### Rotating the Barrel Assembly:

1. Loosen the barrel rotation knobs located at the bottom of the fixture (do not remove the knobs or the barrel assembly).
2. Rotate the barrel into the desired position.
3. Once the barrel is rotated, tighten the barrel rotation knobs.

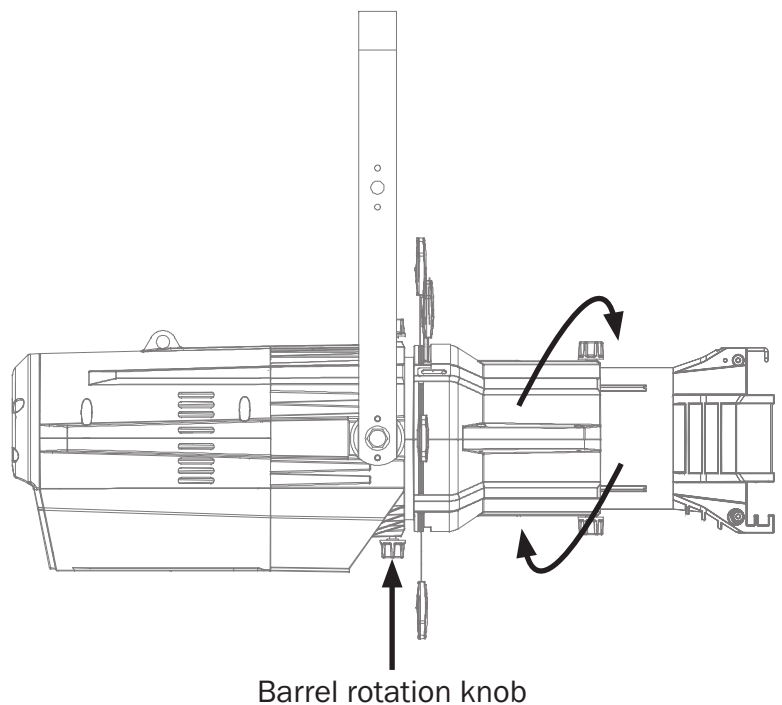

### Accessory Slot:

The Virtuoso 1000 Profile RGBAL has an accessory slot, which holds a drop-in iris or a motorised pattern device (sold separately). When the slot is not in use a small metal cover secures the slot with 2 screws to prevent light leakage.

1. Use a screwdriver to loosen the screws on the slot cover (do not remove the screws).
2. Slide to cover completely forward to expose the slot.
3. Insert the iris or motorised pattern device. When installing an iris, install the flat side towards the shutters and make sure the iris handle extends upwards from the slot.
4. Slide the cover back towards the shutters until it meets the iris handle. Make sure any handles or adjustment tools that stick out the top are able to function correctly.
5. Secure the slot with the tightening screws.

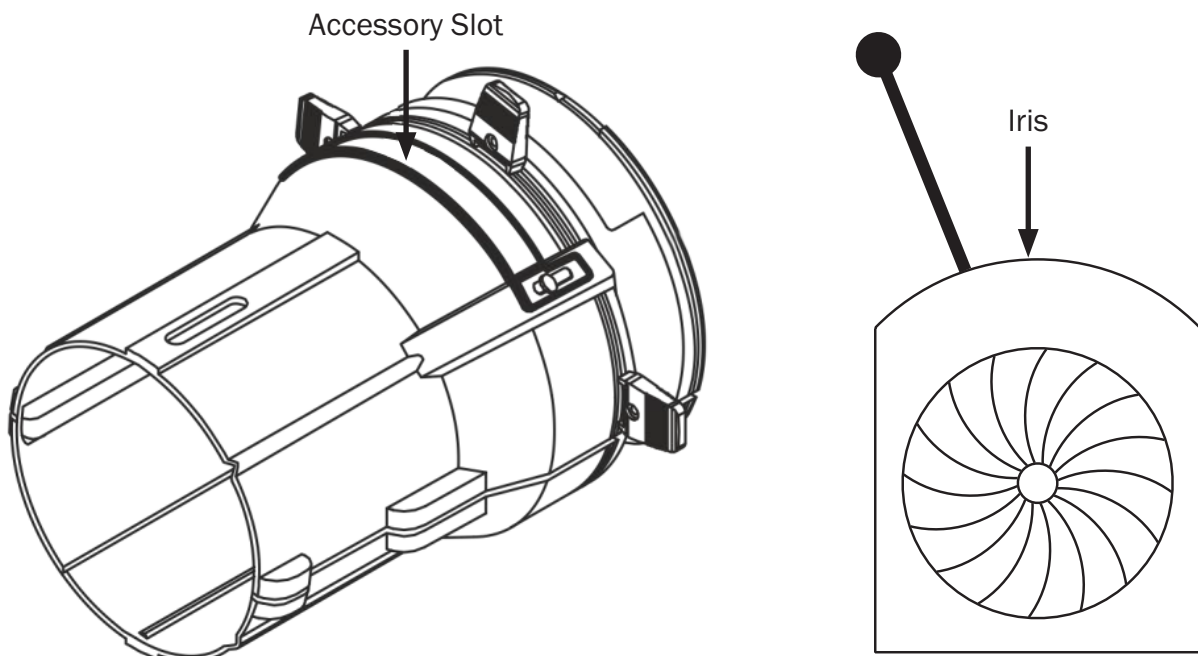



### Shutters:

The shutters are located inside the barrel. They can be adjusted via the shutter handles to adjust the shape of the beam.

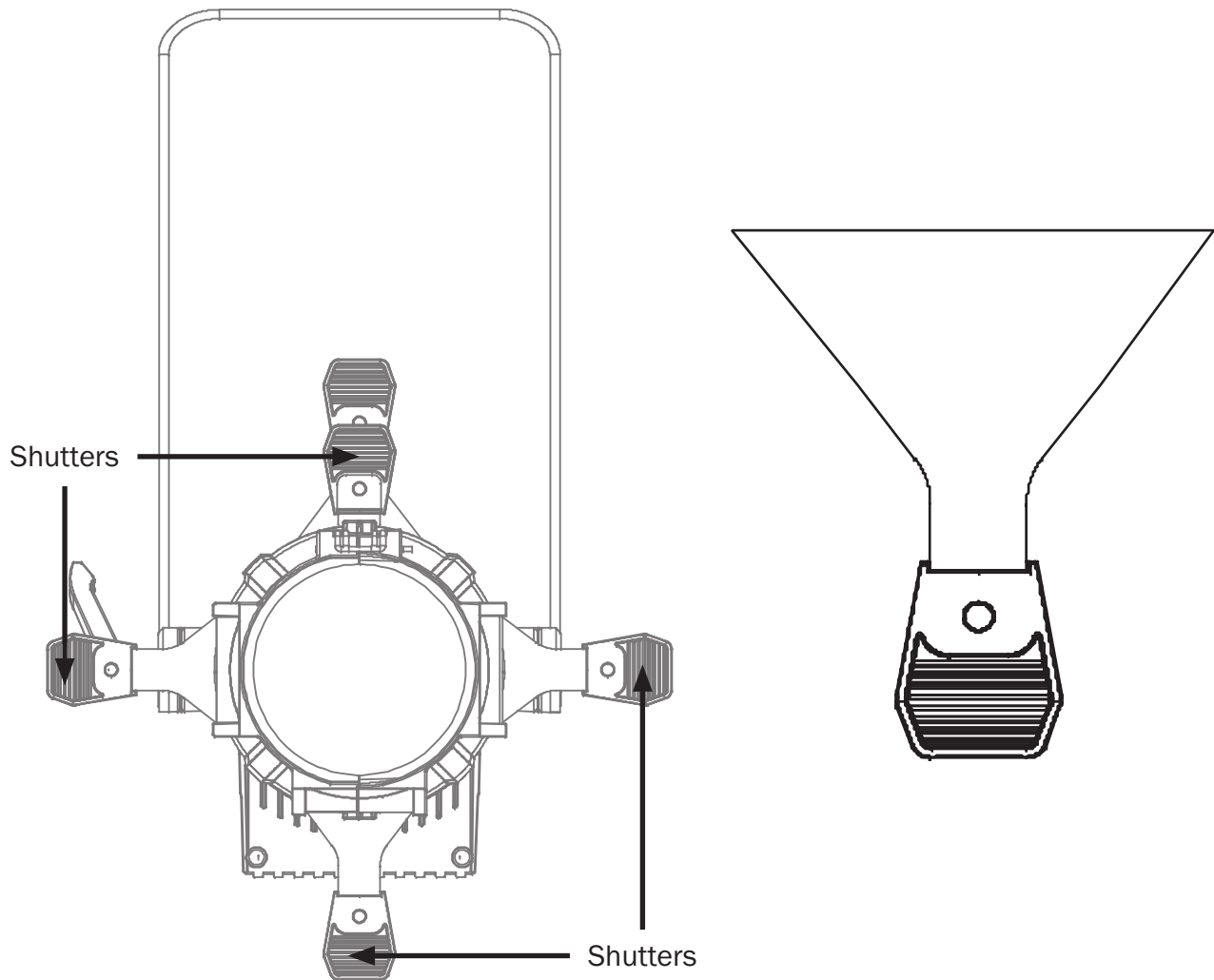

### Control Panel Menu:

The LCD control panel situated on the rear of the fixture allows the user to access the menu system to adjust the fixtures settings.

When the unit has been powered on the display will show “eLumen8”.



The fixture will then return to its home screen.

Please note: when DMX signal is being received the display will show a small 'Y' icon on the top right.

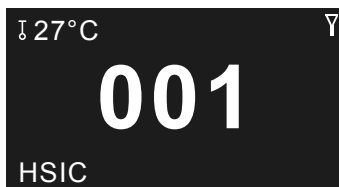

Pressing the “ENTER” button once will take the user to the fixtures main menu. Using the “UP” and “DOWN” buttons you can then navigate between the different options in the main menu. Pressing the “ENTER” button on one of these options allows you to access the sub menu where you can use the “UP” and “DOWN” buttons to select option/value required. Once the option/value has been selected press the “ENTER” button once more to confirm the setting.

To exit out of any of the above options, press the “MENU” button.



### Static colour mode:

To access static colour mode, press the “ENTER” button and use the “UP” and “DOWN” buttons until “STATIC” is highlighted on the LCD display. Press the “ENTER” button and use the “UP” and “DOWN” buttons to select the various options. Press the “ENTER” button and use the “UP” and “DOWN” buttons to select between “0” - “255” (Red, Green, Blue, Amber and Lime) or “0” - “25” (Strobe). Press the “ENTER” button to confirm the setting.

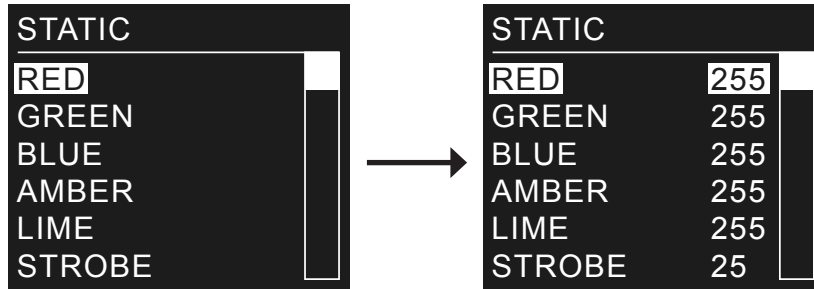

### Preset colour mode:

To access preset colour mode, press the “MENU” button and use the “UP” and “DOWN” buttons until “PRESET COLOUR” is highlighted on the LCD display. Press the “ENTER” button and use the “UP” and “DOWN” buttons to select the various colours. Press the “ENTER” button to confirm the setting.

**L106** - Primary Red

**R05** - Rose Tint

**L194** - Surprise Pink

**R54** - Special Lavender

**L019** - Fire

**R08** - Pale Gold

**R89** - Moss Green

**R86** - Pea Green

**L213** - White Flame Green

**R377** - Iris Purple

**R80** - Primary Blue

**L202** - Half C.T. Blue

**L328** - Follies Pink

**R3314** - Tough 1/4 Minusgreen

**L101** - Yellow

**L768** - Egg Yolk Yellow

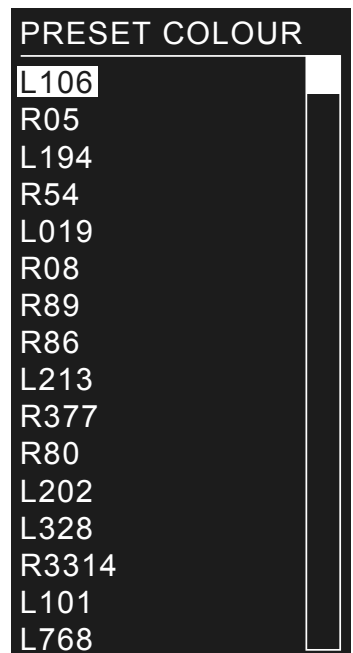

### DMX address setting:

To access the fixtures DMX address setting, press the “MENU” button and use the “UP” and “DOWN” buttons until “ADDRESS” is highlighted on the LCD display. Press the “ENTER” button and use the “UP” and “DOWN” buttons to select between “001” - “512”.

Press the “ENTER” button to confirm the setting.



### Run mode setting:

To access the fixtures run mode setting, press the “MENU” button and use the “UP” and “DOWN” buttons until “RUN MODE” is highlighted on the LCD display. Press the “ENTER” button and use the “UP” and “DOWN” buttons to select between “DMX” or “SLAVE”.

Press the “ENTER” button to confirm the setting.

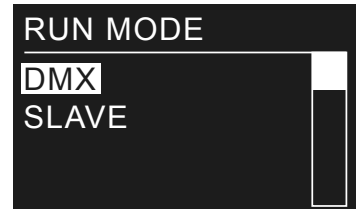

**DMX** - Use this setting when using via a DMX controller.

**SLAVE** - Use this setting when using the fixture via master/slave.

### Channel mode (personality) setting:

To access the fixtures channel mode (personality) setting, press the “MENU” button and use the “UP” and “DOWN” buttons until “PERSONALITY” is highlighted on the LCD display. Press the “ENTER” button and use the “UP” and “DOWN” buttons to select between “HSIC” (8 channel), “SIMPLE” (8 channel), “SDO” (6 channel), “COLOUR 8BIT” (11 channel) or “COLOUR 16BIT” (17 channel).

Press the “ENTER” button to confirm the setting.

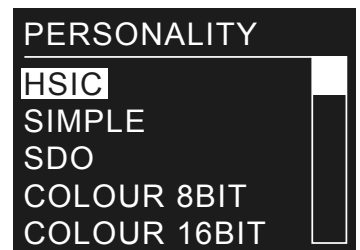

### Settings menu:

To access the fixtures settings menu, press the “MENU” button and use the “UP” and “DOWN” buttons until “SETTING” is highlighted on the LCD display. Press the “ENTER” button. “Pass code” will now be displayed and a button press combination will need to be entered. To do this press the buttons in the following order; “UP”, “DOWN”, “UP”, “DOWN”, “ENTER”. You can now access the sub menus as described below.

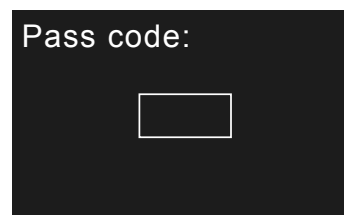
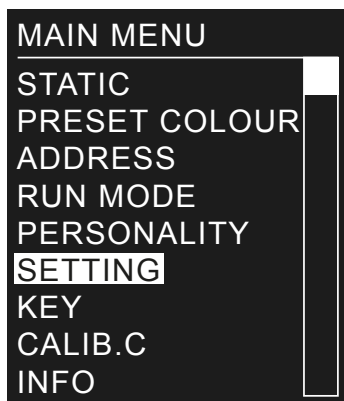

### Upload setting:

This setting allows custom programs to be sent to Slave fixtures.

To access the fixtures upload setting, use the “UP” and “DOWN” buttons to select “UPLOAD”.

Press the “ENTER” button. “Pass code” will now be displayed and a button press combination will need to be entered. To do this press the buttons in the following order; “UP”, “DOWN”, “UP”, “DOWN”, “ENTER”. The unit will display “SEND. . .” and the front lens will illuminate yellow whilst exporting to the slave units. The front lens will turn green if the export has completed successfully. If there are any problems whilst exporting the front lens will turn red.



### Reset setting:

To access the fixtures reset setting, use the “UP” and “DOWN” buttons to select “RESET”. Press the “ENTER” button. “Pass code” will now be displayed and a button press combination will need to be entered. To do this press the buttons in the following order; “UP”, “DOWN”, “UP”, “DOWN”, “ENTER”. The unit will display “RESET. . .” and the fixtures settings will return to the factory settings.



### Dimming speed setting:

To access the dimming speed setting, use the “UP” and “DOWN” buttons to select “DIMMER”. Press the “ENTER” button and use the “UP” and “DOWN” buttons to select between “OFF”, “DIM1”, “DIM2”, “DIM3”, and “DIM4”. Press the “ENTER” button to confirm the setting.

**DIM1-DIM4** - Dimmer speed fast-slow.

**OFF** - Dimmer speed off.

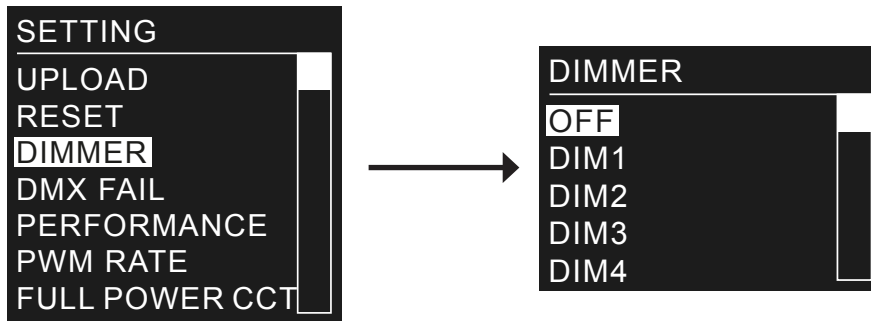

### DMX fail setting:

To access the DMX fail setting, use the “UP” and “DOWN” buttons to select “DMX FAIL”. Press the “ENTER” button and use the “UP” and “DOWN” buttons to select between “SAVE” and “BLACK”. Press the “ENTER” button to confirm the setting.

**SAVE** - The fixture will remember the last DMX signal.

**BLACK** - The fixture will blackout when the DMX signal is lost.

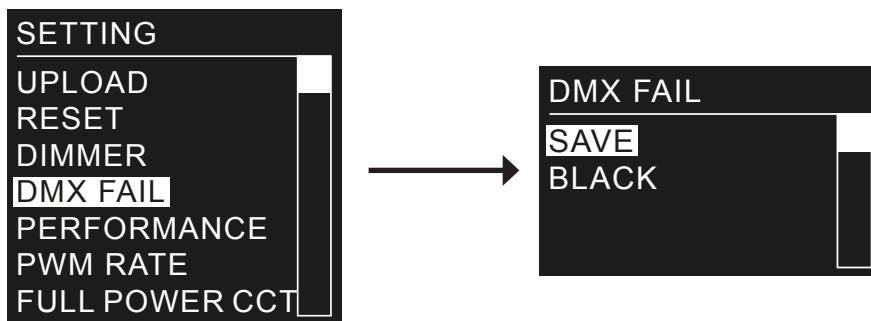

### Fan control setting:

This setting allows the performance of the cooling fan to be adjusted.

To access the fan control setting, use the “UP” and “DOWN” buttons to select “PERFORMANCE”. Press the “ENTER” button and use the “UP” and “DOWN” buttons to select between “LIVE”, “STUDIO” and “POWER”. Press the “ENTER” button to confirm the setting.

**LIVE** - This is the default performance mode. This provides a compromise between both output quality and noise level.

**STUDIO** - This is a noise level performance mode designed to operate at the lowest noise possible but with a moderate output.

**POWER** - This is an output performance mode designed to operate at full power with no consideration for the noise level.

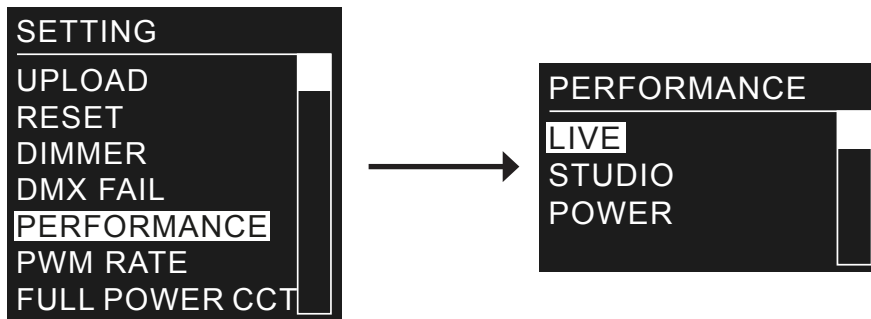

### PWM rate setting (refresh rate):

This setting allows the refresh rate to be adjusted.

To access the PWM rate setting, use the “UP” and “DOWN” buttons to select “PWM RATE”. Press the “ENTER” button and use the “UP” and “DOWN” buttons to select between “600Hz”, “1200Hz”, “2000Hz”, “2400Hz”, “6000Hz”, and “25000Hz”. Press the “ENTER” button to confirm the setting.

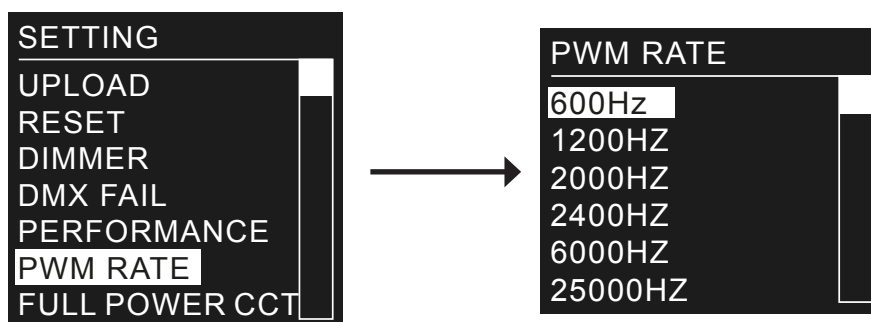

### Power CCT setting (correlated colour temperature):

This setting allows the colour temperature to be adjusted.

To access the CCT setting, use the “UP” and “DOWN” buttons to select “FULL POWER CCT”. Press the “ENTER” button and use the “UP” and “DOWN” buttons to select between “3200K”, “4200K”, “5600K”, “10000K”, and “NORMAL”. Press the “ENTER” button to confirm the setting.

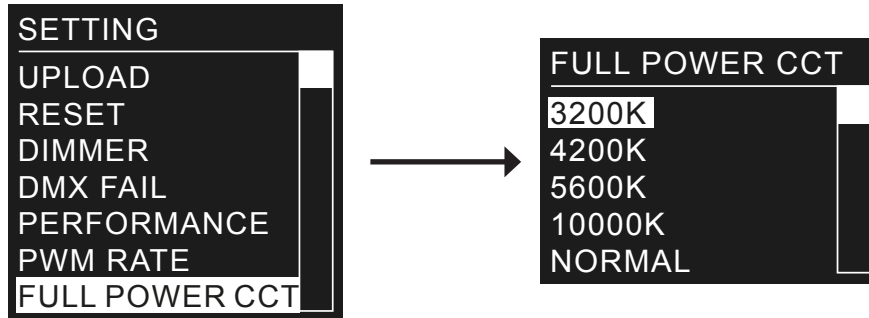

### XY Offset:

There is also an “XY OFFSET”, sub menu within the settings menu this can be set between “HIDE” (default) and “SHOW”. When set to show this will display the XY OFFSET calibrations in some menus.

These calibrations have been set when the fixture was being manufactured to ensure the colour consistency throughout fixtures from different batches. These settings should NOT be changed.

If these settings are accidentally changed then the “RESET” function can be used to reset them to the defaults (see page 13).

### Safety lock setting:

To access safety lock setting, press the “ENTER” button and use the “UP” and “DOWN” buttons until “KEY” is highlighted on the LCD display. Press the “ENTER” button and use the “UP” and “DOWN” buttons to between “ON” and “OFF”. Press the “ENTER” button to confirm the setting.

When this is set to ON, the passcode will need to be entered each time the display goes off.

The passcode sequence is; “UP”, “DOWN”, “UP”, “DOWN”, “ENTER”.

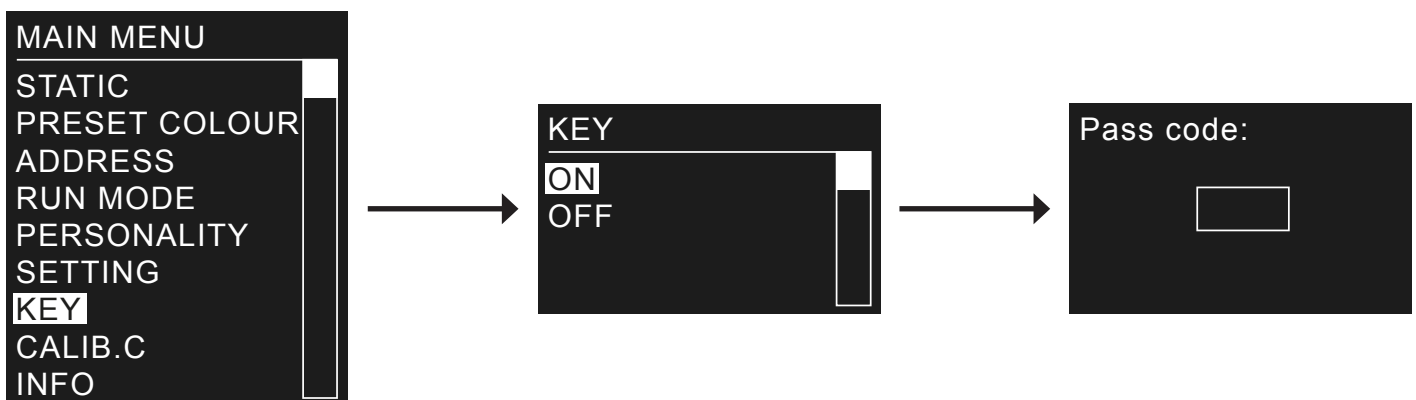



### Colour calibration setting:

To access the colour calibration setting, press the “ENTER” button and use the “UP” and “DOWN” buttons until “CALIB.CCT” is highlighted on the LCD display. Press the “ENTER” button.

“Pass code” will now be displayed and a button press combination will need to be entered.

To do this press the buttons in the following order; “UP”, “DOWN”, “UP”, “DOWN”, “ENTER”.

“CCT” will be displayed, press the “ENTER” button and the “UP” and “DOWN” buttons to select between “2700K”, “3000K”, “3200K”, “3500K”, “4000K”, “4200K”, “4500K”, “5600K”, “6000K”, “6500K”, “7200K”, “8000K” and “10000K”.

Press the “ENTER” button to enter the selected menu. Now use the “UP” and “DOWN” buttons to select between “X FINE”, and “Y FINE” (these settings will adjust the tint of the CCT). Press the “ENTER” button and use the “UP” and “DOWN” buttons to adjust between “-200”, and “+200”.

Press the “ENTER” button to confirm the setting.

Please note: XY Offset must be set to show to adjust colour calibration (see page 16).

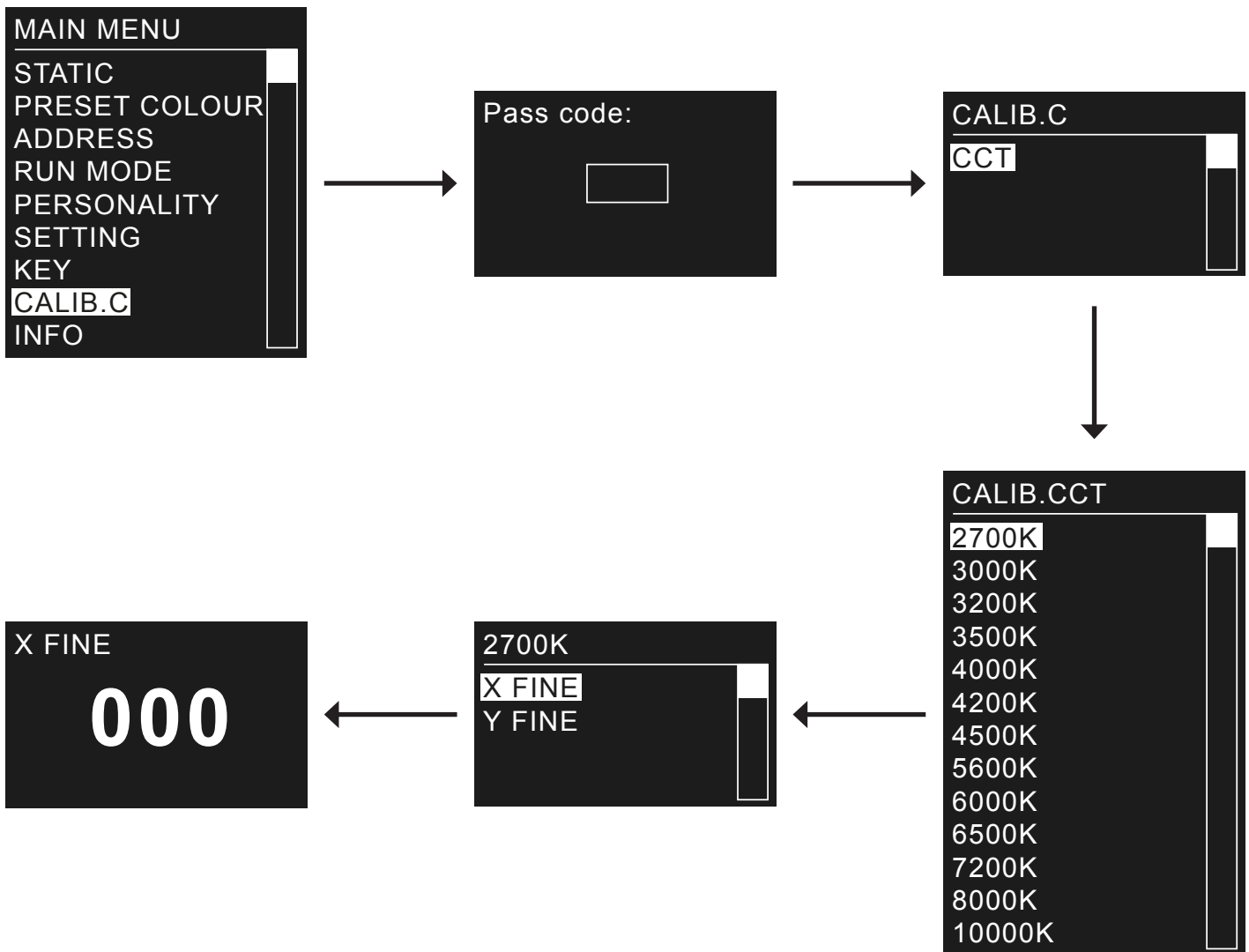

### Fixture information:

To access the fixture information press the “ENTER” button and use the “UP” and “DOWN” buttons until “INFO” is highlighted on the LCD display. Press the “ENTER” button and use the “UP” and “DOWN” buttons to select between “VERSION” and “RDM”. If VERSION is highlighted press the “ENTER” button and the version number and manufacture date will be displayed. If RDM is highlighted, press the “ENTER” button and use the “UP” and “DOWN” buttons to select between “UID” and “LABEL”. If UID is highlighted press the “ENTER” button and the fixtures RDM UID will be displayed. If LABEL is highlighted press the “ENTER” button and the model number will be displayed.

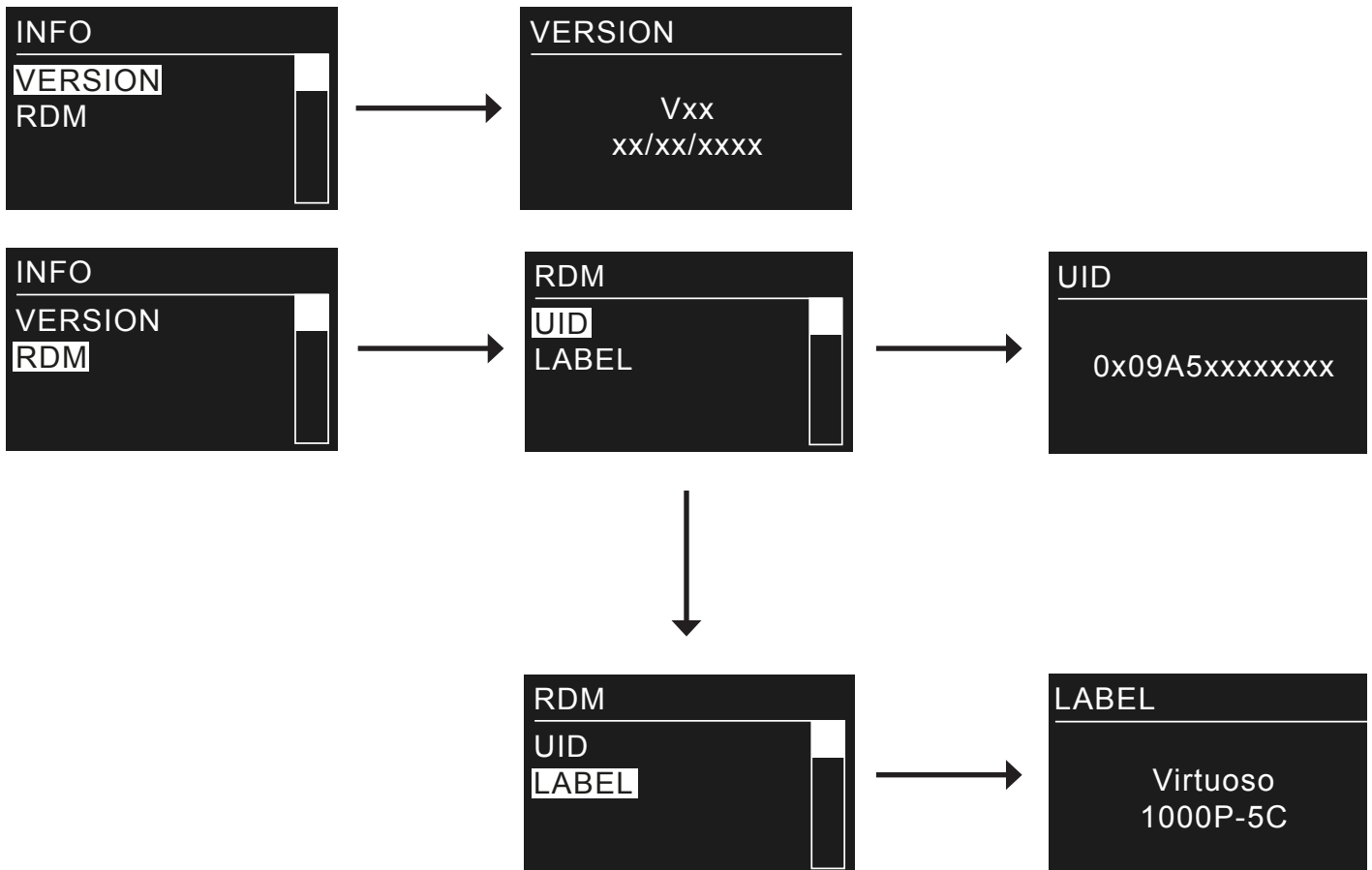

## 8 channel mode (HSIC):

Channel	Value	Function
CH1	000-255	Intensity (0-100%)
CH2	000-255	Hue
CH3	000-255	Hue fine
CH4	000-255	Saturation
CH5	000-010	No function
	011-030	2700K
	031-050	3000K
	051-070	3200K
	071-090	3500K
	091-110	4000K
	111-130	4200K
	131-150	4500K
	151-170	5600K
	171-190	6000K
	191-210	6500K
	211-230	7200K
	231-255	8000K
CH6	000-009	No function
	010-099	Strobe (slow-fast)
	100-109	No function
	110-179	Lightning strobe
	180-189	No function
	190-255	Random strobe
CH7	000-009	Dimming mode (set in menu)
	010-029	No function
	030-069	Dimming speed 1
	070-129	Dimming speed 2
	130-189	Dimming speed 3
	190-255	Dimming speed 4
CH8	000-009	No function
	010-080	Live performance mode
	081-160	Studio performance mode
	161-240	Power performance mode
	241-255	No function

## 8 channel mode (SIMPLE):

Channel	Value	Function
CH1	000-255	Master dimmer (0-100%)
CH2	000-255	Red (0-100%)
CH3	000-255	Green (0-100%)
CH4	000-255	Blue (0-100%)
CH5	000-255	Amber (0-100%)
CH6	000-255	Lime (0-100%)
CH7	000-009	No function
	010-099	Strobe (slow-fast)
	100-109	No function
	110-179	Lightning strobe
	180-189	No function
CH8	190-255	Random strobe
	000-009	No function
	010-080	Live performance mode
	081-160	Studio performance mode
	161-240	Power performance mode
241-255	No function	

### 6 channel mode (SDO):

Channel	Value	Function	
CH1	000-255	Master dimmer (0-100%)	
CH2	000-010	No function	
	011-020	L106 - Primary Red	
	021-030	R05 - Rose Tint	
	031-040	L194 - Surprise Pink	
	041-050	R54 - Special Lavender	
	051-060	L019 - Fire	
	061-070	R08 - Pale Gold	
	071-080	R89 - Moss Green	
	081-090	R86 - Pea Green	
	091-100	L213 - White Flame Green	
	101-110	R377 - Iris Purple	
	111-120	R80 - Primary Blue	
	121-130	L202 - Half C.T. Blue	
	131-140	L328 - Follies Pink	
	141-150	R3314 - Tough 1/4 Minusgreen	
	151-160	L101 - Yellow	
	161-170	L768 - Egg Yolk Yellow	
	171-255	No function	
	CH3	000-010	No function
		011-030	2700K
031-050		3000K	
051-070		3200K	
071-090		3500K	
091-110		4000K	
111-130		4200K	
131-150		4500K	
151-170		5600K	
171-190		6000K	
191-210		6500K	
211-230		7200K	
231-255		8000K	
CH4	000-009	No function	
	010-099	Strobe (slow-fast)	
	100-109	No function	
	110-179	Lightning strobe	
	180-189	No function	
	190-255	Random strobe	

Channel	Value	Function
CH5	000-009	Dimming mode (set in menu)
	010-029	No function
	030-069	Dimming speed 1
	070-129	Dimming speed 2
	130-189	Dimming speed 3
	190-255	Dimming speed 4
CH6	000-009	No function
	010-080	Live performance mode
	081-160	Studio performance mode
	161-240	Power performance mode
	241-255	No function

### 11 channel mode (COLOUR 8BIT):

Channel	Value	Function
CH1	000-255	Master dimmer (0-100%)
CH2	000-255	Red (0-100%)
CH3	000-255	Green (0-100%)
CH4	000-255	Blue (0-100%)
CH5	000-255	Amber (0-100%)
CH6	000-255	Lime (0-100%)
CH7	000-010	No function
	011-020	L106 - Primary Red
	021-030	R05 - Rose Tint
	031-040	L194 - Surprise Pink
	041-050	R54 - Special Lavender
	051-060	L019 - Fire
	061-070	R08 - Pale Gold
	071-080	R89 - Moss Green
	081-090	R86 - Pea Green
	091-100	L213 - White Flame Green
	101-110	R377 - Iris Purple
	111-120	R80 - Primary Blue
	121-130	L202 - Half C.T. Blue
	131-140	L328 - Follies Pink
	141-150	R3314 - Tough 1/4 Minusgreen
	151-160	L101 - Yellow
161-170	L768 - Egg Yolk Yellow	
171-255	No function	
CH8	000-010	No function
	011-030	2700K
	031-050	3000K
	051-070	3200K
	071-090	3500K
	091-110	4000K
	111-130	4200K
	131-150	4500K
	151-170	5600K
	171-190	6000K
	191-210	6500K
	211-230	7200K
	231-255	8000K

Channel	Value	Function
CH9	000-009	No function
	010-099	Strobe (slow-fast)
	100-109	No function
	110-179	Lightning strobe
	180-189	No function
	190-255	Random strobe
CH10	000-009	Dimming mode (set in menu)
	010-029	No function
	030-069	Dimming speed 1
	070-129	Dimming speed 2
	130-189	Dimming speed 3
	190-255	Dimming speed 4
CH11	000-009	No function
	010-080	Live performance mode
	081-160	Studio performance mode
	161-240	Power performance mode
	241-255	No function

### 17 channel mode (COLOUR 16BIT):

Channel	Value	Function
CH1	000-255	Master dimmer (0-100%)
CH2	000-255	Dimmer fine (0-100%)
CH3	000-255	Red (0-100%)
CH4	000-255	Red fine (0-100%)
CH5	000-255	Green (0-100%)
CH6	000-255	Green fine (0-100%)
CH7	000-255	Blue (0-100%)
CH8	000-255	Blue fine (0-100%)
CH9	000-255	Amber (0-100%)
CH10	000-255	Amber fine (0-100%)
CH11	000-255	Lime (0-100%)
CH12	000-255	Lime fine (0-100%)
CH13	000-010	No function
	011-020	L106 - Primary Red
	021-030	R05 - Rose Tint
	031-040	L194 - Surprise Pink
	041-050	R54 - Special Lavender
	051-060	L019 - Fire
	061-070	R08 - Pale Gold
	071-080	R89 - Moss Green
	081-090	R86 - Pea Green
	091-100	L213 - White Flame Green
	101-110	R377 - Iris Purple
	111-120	R80 - Primary Blue
	121-130	L202 - Half C.T. Blue
	131-140	L328 - Follies Pink
	141-150	R3314 - Tough 1/4 Minusgreen
	151-160	L101 - Yellow
161-170	L768 - Egg Yolk Yellow	
171-255	No function	

Channel	Value	Function
CH14	000-010	No function
	011-030	2700K
	031-050	3000K
	051-070	3200K
	071-090	3500K
	091-110	4000K
	111-130	4200K
	131-150	4500K
	151-170	5600K
	171-190	6000K
	191-210	6500K
CH15	211-230	7200K
	231-255	8000K
	000-009	No function
	010-099	Strobe (slow-fast)
	100-109	No function
	110-179	Lightning strobe
	180-189	No function
190-255	Random strobe	
CH16	000-009	Dimming mode (set in menu)
	010-029	No function
	030-069	Dimming speed 1
	070-129	Dimming speed 2
	130-189	Dimming speed 3
190-255	Dimming speed 4	
CH17	000-009	No function
	010-080	Live performance mode
	081-160	Studio performance mode
	161-240	Power performance mode
	241-255	No function

### 19° Fixed Lens

19° - Lux

FULL ON	92124	23031	10236	5757	3684
R	6716	1679	746	419	268
G	17976	4494	1997	1123	719
B	3112	778	345	194	124
A	23108	5777	2567	1444	924
L	83404	20851	9267	5212	3336

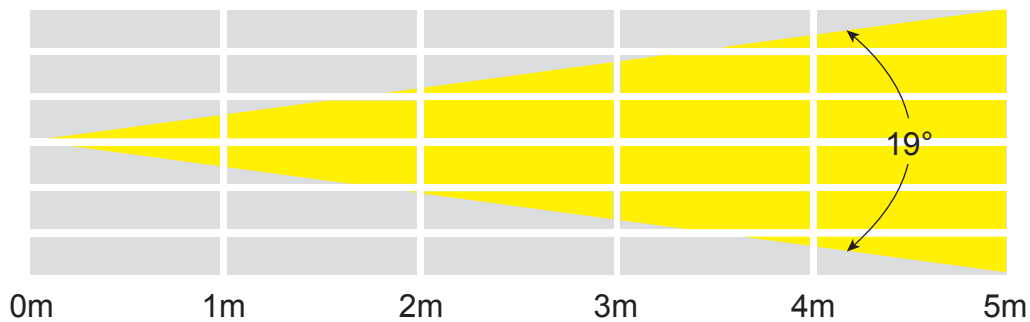

### 26° Fixed Lens

26° - Lux

FULL ON	60800	15200	6755	3800	2432
R	5508	1377	612	344	220
G	11996	2999	1332	749	479
B	2100	525	233	131	84
A	13432	3358	1492	839	537
L	39640	9910	4404	2477	1585

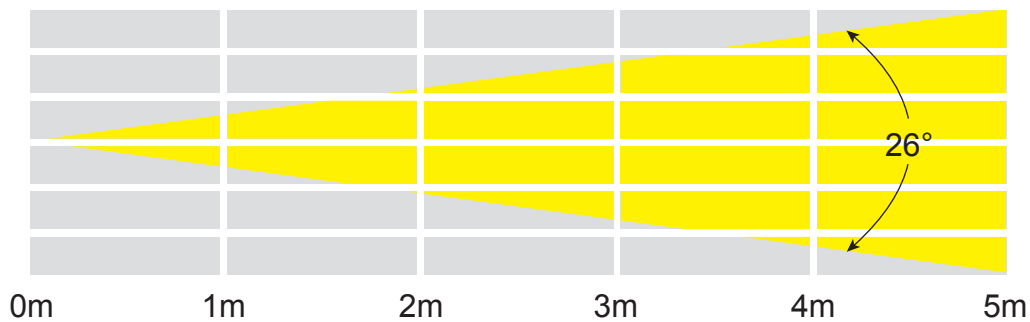

### 36° Fixed Lens

36° - Lux

FULL ON	40000	10000	4444	2500	1600
R	3720	930	413	232	148
G	8544	2136	949	534	341
B	1432	358	159	89.5	57.2
A	8832	2208	981	552	353
L	27368	6842	3040	1710	1094

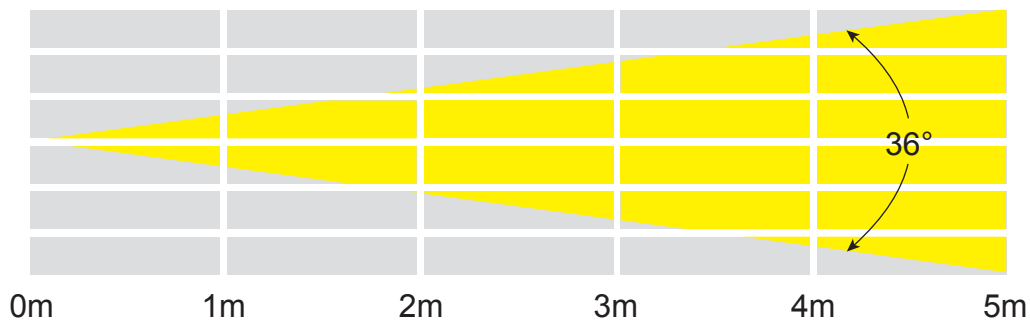

### 50° Fixed Lens

50° - Lux

FULL ON	10356	2589	1150	647	414
R	1456	364	161	91	58.2
G	3396	849	377	212	135
B	572	143	63.5	35.7	22.8
A	3652	913	405	228	146
L	10944	2736	1216	684	437

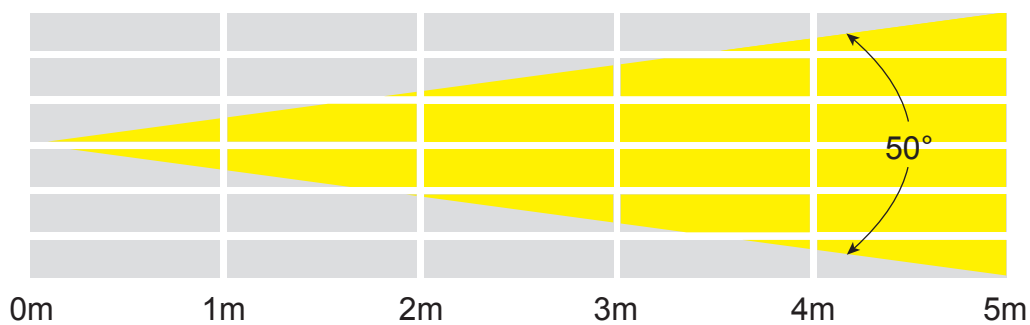



### 15-30° Fixed Lens

15° - Lux

FULL ON	107944	26986	11993	6746	4317
R	9572	2393	1063	598	382
G	25612	6403	2845	1600	1024
B	4124	1031	458	257	164
A	35740	8935	3971	2233	1429
L	83404	20851	9267	5212	3336

30° - Lux

FULL ON	51432	12858	5714	3214	2057
R	3684	921	409	230	147
G	9084	2271	1009	567	363
B	1548	387	172	96	91.9
A	10576	2644	1175	661	423
L	31068	7767	3452	1941	1242

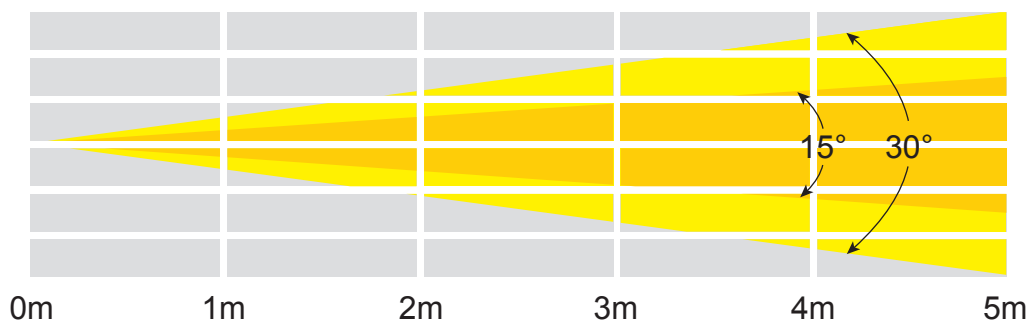

### 25-50° Fixed Lens

25° - Lux

FULL ON	58480	14620	6497	3655	2339
R	5192	1298	576	324	207
G	12232	3058	1359	764	489
B	2064	516	229	129	82.5
A	12788	3197	1420	799	511
L	39924	9981	4436	2495	1596

50° - Lux

FULL ON	21000	5250	2333	1312	840
R	1948	487	216	121	77.9
G	4452	1113	494	278	178
B	736	184	81.7	46	29.4
A	4772	1193	530	298	190
L	14104	3526	1567	881	564

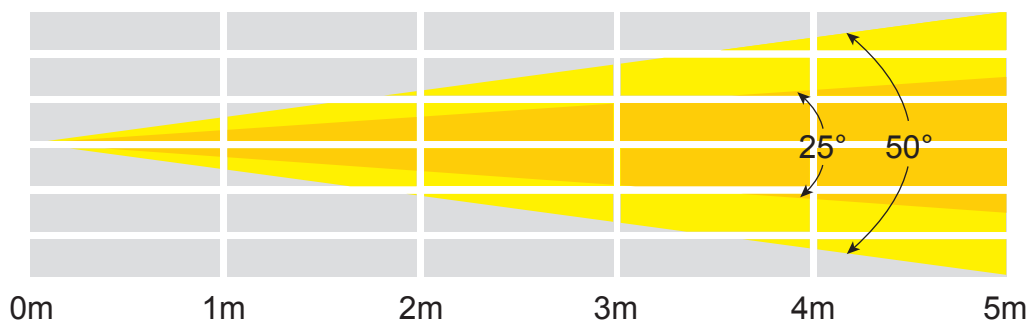

### Setting the DMX address:

The DMX mode enables the use of a universal DMX controller. Each fixture requires a “start address” from 1- 512. A fixture requiring one or more channels for control begins to read the data on the channel indicated by the start address. For example, a fixture that occupies or uses 7 channels of DMX and was addressed to start on DMX channel 100, would read data from channels: 100, 101, 102, 103, 104, 105 and 106. Choose a start address so that the channels used do not overlap. E.g. the next unit in the chain starts at 107.

### DMX 512:

DMX (Digital Multiplex) is a universal protocol used as a form of communication between intelligent fixtures and controllers. A DMX controller sends DMX data instructions from the controller to the fixture. DMX data is sent as serial data that travels from fixture to fixture via the DATA “IN” and DATA “OUT” XLR terminals located on all DMX fixtures (most controllers only have a data “out” terminal).

### DMX linking:

DMX is a language allowing all makes and models of different manufactures to be linked together and operate from a single controller, as long as all fixtures and the controller are DMX compliant. To ensure proper DMX data transmission, when using several DMX fixtures try to use the shortest cable path possible. The order in which fixtures are connected in a DMX line does not influence the DMX addressing. For example; a fixture assigned to a DMX address of 1 may be placed anywhere in a DMX line, at the beginning, at the end, or anywhere in the middle. When a fixture is assigned a DMX address of 1, the DMX controller knows to send DATA assigned to address 1 to that unit, no matter where it is located in the DMX chain.

### DATA cable (DMX cable) requirements (for DMX operation):

This fixture can be controlled via DMX-512 protocol. The DMX address is set on the back of the unit. Your unit requires either a standard 3-pin or 5-pin XLR connector for data input/output, see images below.



Further DMX cables can be purchased from all good sound and lighting suppliers or Prolight Concepts dealers.

Please quote:	3-Pin:	<b>CABL10 - 2m</b>	<b>CABL11 - 5m</b>	<b>CABL12 - 10m</b>
	5-Pin:	<b>CABL185 - 2m</b>	<b>CABL187 - 5m</b>	<b>CABL188 - 10m</b>

Also remember that DMX cable must be daisy chained and cannot be split.

**Notice:**

Be sure to follow the diagrams below when making your own cables. Do not connect the cables shield conductor to the ground lug or allow the shield conductor to come in contact with the XLRs outer casing. Grounding the shield could cause a short circuit and erratic behaviour.

Pin Configuration	
3-Pin	5-Pin
	Pin 1 - Ground
	Pin 2 - Negative
	Pin 3 - Positive
-	Pin 4 - N/C
-	Pin 5 - N/C

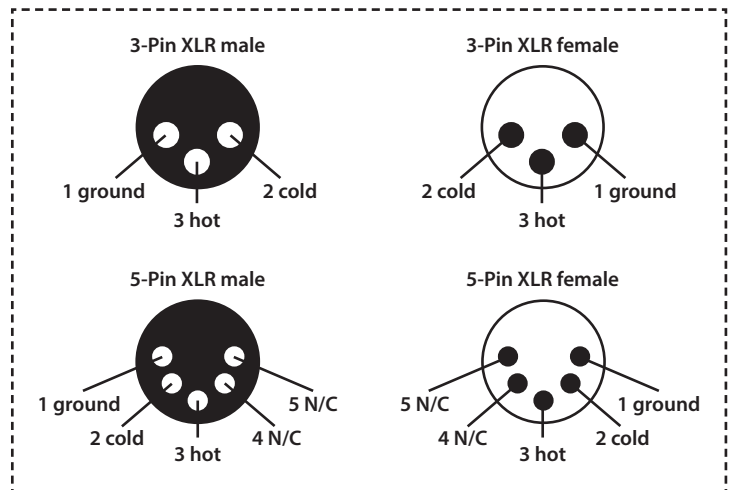
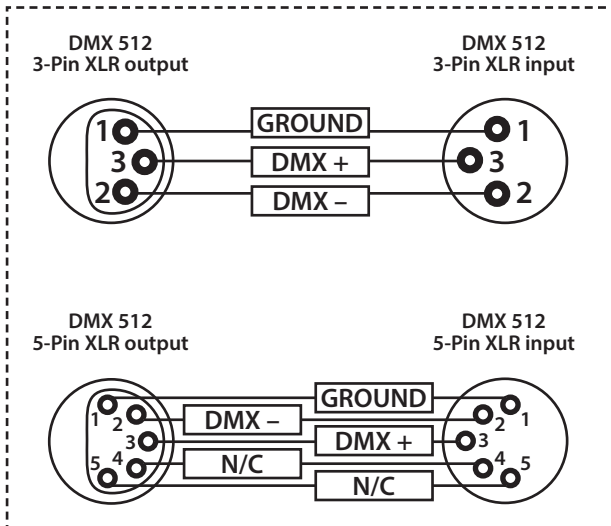

**Line termination:**

When longer runs of cable are used, you may need to use a terminator on the last unit to avoid erratic behaviour.

**Using a cable terminator will decrease the possibilities of erratic behaviour.**

(3-pin - Order ref: CABL90,  
5-pin - Order ref: CABL89)

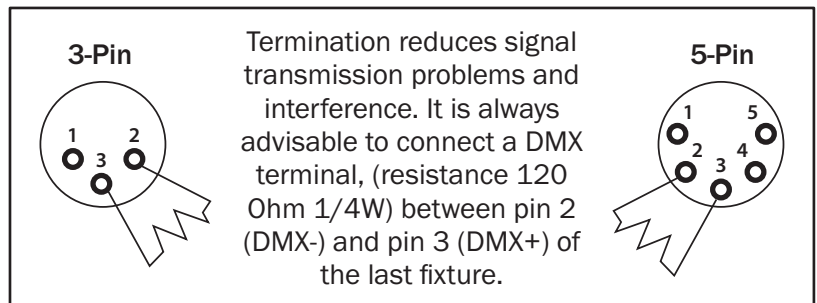

**5-pin XLR DMX connectors:**

Some manufactures use 5-pin XLR connectors for data transmission in place of 3-pin. 5-pin XLR fixtures may be implemented in a 3-pin XLR DMX line. When inserting standard 5-pin XLR connectors in to a 3-pin line a cable adaptor must be used. The diagram below details the correct cable conversion.

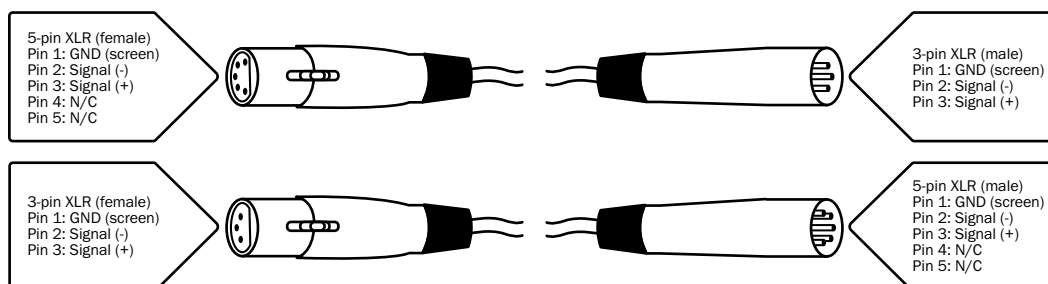

### Power linking:

This fixture provides power linking via the power output on the rear allowing multiple units to be connected together. The maximum number of fixtures that can be connected is 6 fixtures @ 240V or 3 fixtures @ 120V (including the first fixture). After the maximum number of fixtures are connected a new power run will need to be started.

Please note: Caution should be used when power linking other fixtures to the Virtuoso 1000 Profile as the power consumption of other fixtures will vary. Fixtures fitted with lamps often require 2/3 times more current on startup, these may require their own power source.

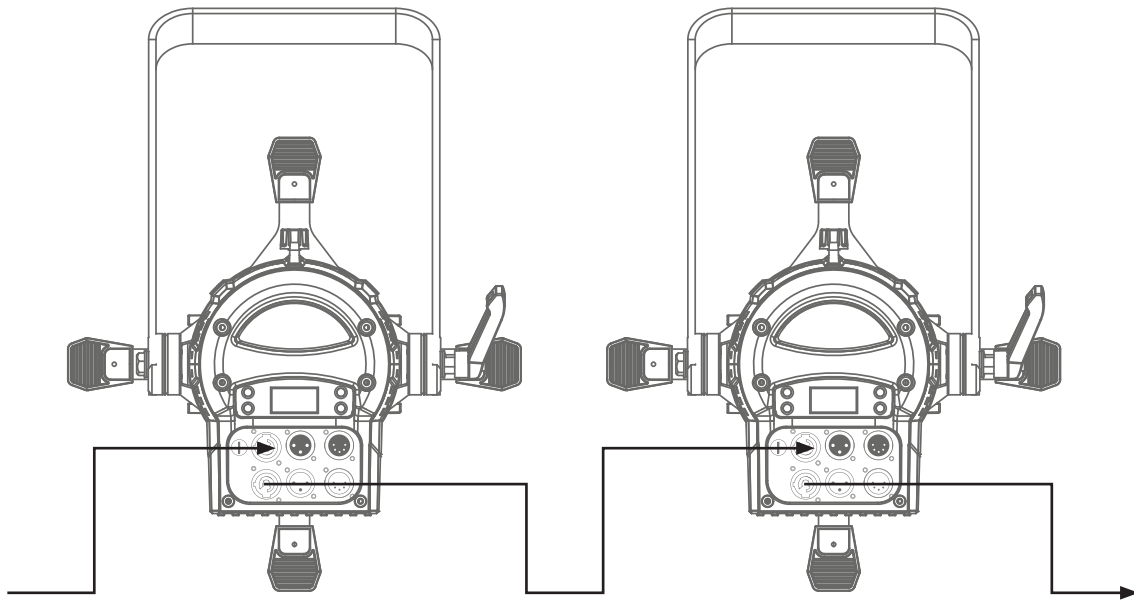



***Correct Disposal of this Product  
(Waste Electrical & Electronic Equipment)***

(Applicable in the European Union and other European countries with separate collection systems)

This marking shown on the product or its literature, indicates that it should not be disposed with other household wastes at the end of its working life. To prevent possible harm to the environment or human health from uncontrolled waste disposal, please separate this from other types of wastes and recycle it responsibly to promote the sustainable reuse of material resources.

Household users should contact either the retailer where they purchased this product, or their local government office, for details of where and how they can take this item for environmentally safe recycling.

Business users should contact their supplier and check the terms and conditions of the purchase contract. This product should not be mixed with other commercial wastes for disposal.





# elumen8