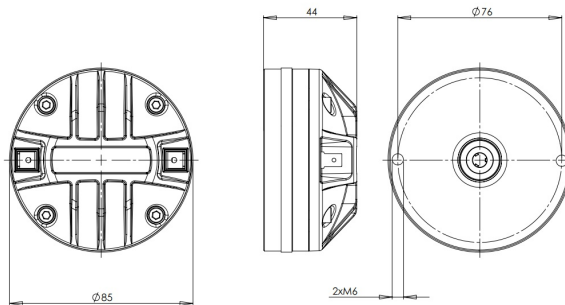

# DE400

**16Ω****HF Drivers - 1.0 Inches**

- 100 W continuous program power capacity
- 1" horn throat diameter
- 44 mm (1.7 in) aluminium voice coil
- Polyimide diaphragm
- 1200 - 18000 Hz response
- 109 dB sensitivity
- Compact Neodymium magnet assembly

# DE400

HF Drivers- 1.0 Inches

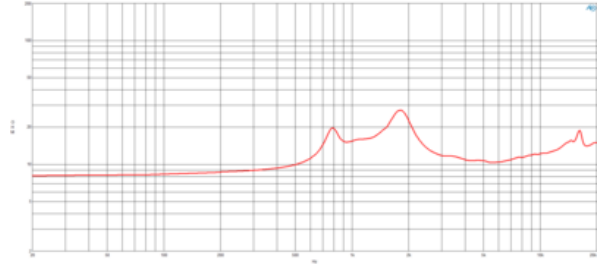
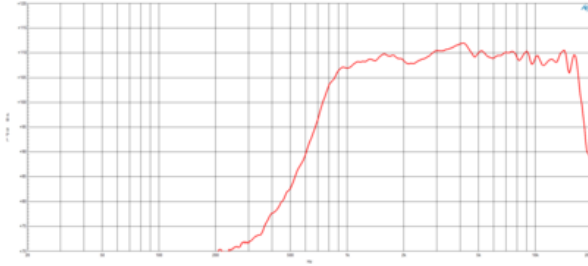

## SPECIFICATIONS<sup>1</sup>

Throat Diameter	25 mm (1.0 in)
Nominal Impedance	16 Ω
Minimum Impedance	10.4 Ω
Nominal Power Handling <sup>2</sup>	50 W
Continuous Power Handling <sup>3</sup>	100 W
Sensitivity <sup>4</sup>	109.0 dB
Frequency Range	1.0 - 18.0 kHz
Recommended Crossover <sup>5</sup>	1.6 kHz
Voice Coil Diameter	44 mm (1.7 in)
Winding Material	Aluminium
Inductance	0.11 mH
Diaphragm Material	Polyimide
Flux Density	1.8 T
Magnet Material	Neodymium Ring

## MOUNTING AND SHIPPING INFO

Two M6 holes 180° on 76 mm (3 in) diameter	
Overall Diameter	85 mm (3.3 in)
Depth	44 mm (1.7 in)
Net Weight	0.8 kg (1.8 lb)
Shipping Units	8
Shipping Weight	7.05 kg (15.54 lb)
Shipping Box	235x235x165 mm (9.25x9.25x6.50 in)

## REPLACEMENT DIAPHRAGM

MMD40016

1. Driver mounted on B&C ME 45 horn.
2. 2 hour test made with continuous pink noise signal within the range from the recommended crossover frequency to 20 kHz. Power calculated on rated minimum impedance.
3. Power on Continuous Program is defined as 3 dB greater than the Nominal rating.
4. Applied RMS Voltage is set to 4 V for 16 ohms Nominal Impedance.
5. 12 dB/oct. or higher slope high-pass filter.