



S-600 Yeti Snow Machine User Manual



© 2022 Antari Lighting and Effects Ltd.

English

1. Introduction	2
2. Safety Information.....	2
3. Package Items.....	5
4. Product Overview.....	6
5. Technical Label Information	7
6. Snow Fluid	7
7. Setting Up.....	7
8. Operation.....	8
9. Machine Status Message	10
10. DMX Connection.....	11
11. RDM	12
12. Wireless Control Operation	13
13. Wireless DMX Operation (Optional)	14
14. SC-4 Wired Remote Operation (Optional)	16
15. S-600-BH / 5-liter bottle holder (Optional)	17
16. Service and Maintenance	18
17. Technical Specifications	18
18. Machine Dimension.....	19
19. Exploded diagram	20



User Manual

1. Introduction

Please read this user manual carefully before operating the machine.

Please put this manual in a place where you can refer to it at any time.

If you encountered any problems, please contact your local Antari dealer for advice and assistance.

2. Safety Information

CAUTION!



Please read the following safety information carefully before operating the machine. This information includes important safeguards about installation, usage and maintenance. Pay attention to all warning labels and instructions in this manual and printed on the machine.

DANGER!



Electrical shock

Always connect the machine to correct voltage. It will lead to electrical shock or burned and may cause serious consequences if connecting to incorrect or improper voltage.

WARNING!



Risk of electrocution

Always connect the machine to a protected circuit and ensure it is properly grounded to avoid risk of electrocution.

※ **Damage caused by the disregard of this user manual are not subject to warranty. Antari and its dealer will not accept liability for any resulting defects or problems.**

2.1 Installation

- Keep this device dry. This machine is not waterproof. Do not expose the machine to water splashes.
- Place the machine on a flat surface. Installed in a well ventilated area. Provide at least 50 cm space around the machine.
- Make sure there are no flammable materials close to the machine while operating. Never add flammable liquid of any kind to the machine.
- Before connecting the machine to power, always check the voltage indicate on the machine matches to your local AC voltage. Do not use the machine if AC power voltage does not match.
- If the supply cord is damaged, it must be replaced by a special cord or assembly available from your local Antari dealer for replacement.
- No user serviceable and modifiable parts inside. Never try to repair this product, an unauthorized technician may lead the machine to damage or malfunction.
- This product is for indoor use only! Do not expose to rain or moisture. If fluid is spilled, disconnect AC power and clean with a damp cloth. If fluid is spilled onto electronic parts, immediately unplug the machine and contact your local Antari dealer for advice.
- Pay attention to all warning labels and instructions on the machine before operation.

2.2 Operation

- Do not operate the machine with bundled power cables. It could be a fire hazard.
- Do not operate the machine in an area with unstable voltage. This may burn out internal components and cause machine fail to work.
- Do not use the machine against human, animal or flame. Make sure there are no flammable materials close to the machine.
- For adult use only. The machine is not to be used by persons (including children) with reduced physical, sensory or mental capabilities, or lack of experience and knowledge. Never leave the machine running unattended.
- Children being supervised not to play with the machine.
- If you hear a strange sound or experience machine fails to work, stop use it immediately. Turn off and unplug the machine, and contact your local Antari dealer for service.
- Turn off and unplug the machine while it's not in use.
- Make sure the machine is turned off before unplug it.
- Do not use the machine upside down or tilt it. It may damage the machine and make it malfunction.
- Before transporting the machine, make sure the fluid tank is completely drained.
- Snow fluid may present health risks if swallowed. Do not drink snow fluid. Store it securely. In case of eye contact or if fluid is swallowed immediately look for medical advice.

- Be sure to unplug the machine before filling snow fluid.
- If the machine fails to work, unplug the machine and stop operation immediately. Contact your local Antari dealer for help.

2.3 Grounding Instruction

This appliance must be grounded in the event of malfunction or breakdown, grounding provides a path of least resistance for electric current to reduce the risk of electric shock. This appliance is equipped with a cord having an equipment-grounding conductor and a grounding plug. The plug must be plugged into an appropriate outlet that is properly installed and grounded in accordance with all local codes and ordinances.

DANGER – Improper connection of the equipment-grounding conductor can result in a risk of electric shock. The conductor with insulation having an outer surface that is green with or without yellow stripes is the equipment-grounding conductor. If repair or replacement of the cord or plug is necessary, do not connect the equipment-grounding conductor to a live terminal. Check with a qualified electrician or servicemen if the grounding instructions are not completely understood, or if in doubt as to whether the appliance is properly grounded. Do not modify the plug provided with the appliance. If it will not fit the outlet, have a proper outlet installed by a qualified electrician.

This appliance is for use on a nominal 120V circuit and has a grounding plug that looks like the plug illustrated in sketch A in Figure 73.1. A temporary adaptor, which looks like the adaptor illustrated in sketches B and C, may be used to connect this plug to a 2 pole receptacle as shown in sketch B if a properly grounded outlet is not available. The temporary adaptor should be used only until a properly grounded outlet can be installed by a qualified electrician. The green colored rigid ear, lug, and the like, extending from the adaptor must be connected to a permanent ground such as a properly grounded outlet box cover. Whenever the adaptor is used, it must be held in place by the metal screw.

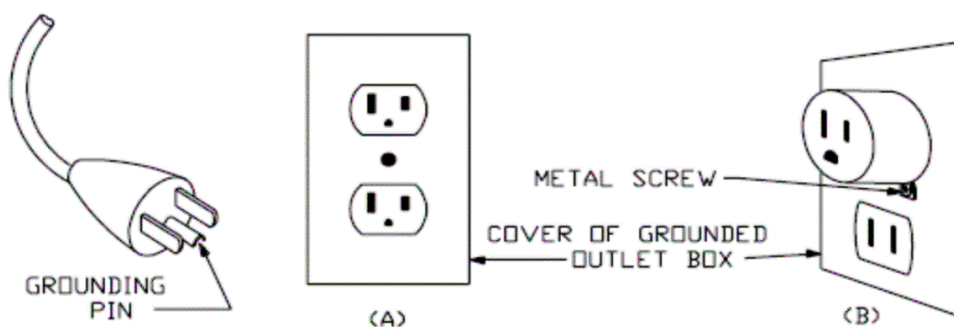

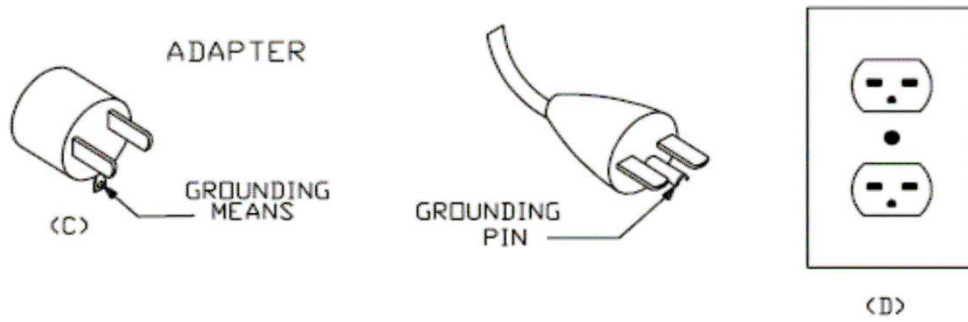

3. Package Items

Immediately upon receiving the machine, carefully unpack the carton, check the content to ensure that all parts are present and have been received in good condition. If any parts appear damaged or mishandled from shipping, notify the shipper immediately and retain the packing material for inspection.

3.1 Standard Package

- 1 x S-600 Snow Machine
- 1 x PowerCon True 1 Power Cord
- 1 x User Manual or scan QR code on technical label
- 1 x 5M Fluid Tank Feed Tube with Filter
- 1 x W-2 Wireless Transmitter (Receiver has been installed onto the machine)
- 1 x Hanging Bracket

3.2 Optional Accessories

Item Code	Description
WTR-90	W-2 & W-DMX Receiver & W-DMX-PCB
SC-4	Cable Remote
S-600-BH	5-Liter Bottle Holder

4. Product Overview



01. Control Panel	02. Fluid Tube Connection
03. Main Power Switch	04. True 1 PowerCon Connector
05. XLR 5-Pin DMX Connector	06. Wireless Receiver Antenna
07. SC-4 Remote Connector	08. Output Nozzle
09. Hanging Bracket	10. Technical Label

5. Technical Label Information

Read the information on the technical label before operation.

Technical label is attached on one side of control panel.



- | | |
|----------------------------|------------------|
| 1. Model Name | 2. Input Voltage |
| 3. Frequency | 4. Rated Power |
| 5. QR CODE for User Manual | 6. Serial No. |

6. Snow Fluid



CAUTION!

Always disconnect from the mains before filling the machine. Never add flammable liquids. If fluid gets inside the machine, please contact your local Antari dealer for service.

Only use Antari SL-N, SL-AN, SL-H, SL-C, SL-UV fluid for the S-600 Snow Machine. The machine is tested and calibrated with this liquid to get the best output performance. Warranty will be void if any other type of liquid is used, improper use of liquid may lead to machine failure and malfunction.

7. Setting Up



CAUTION!

Risk of injury caused by falling objects.

Make sure installation location, fastening connecting and rigging hardware can hold at least 10 times the weight of the machine.

Make sure that the machine is installed securely and cannot fall down.

It will cause severe injuries if the machine falling down.

- Step 1.** Place the machine on a flat surface and in a suitably large area with at least 50 cm open space around the machine.
- Step 2.** Connect the 5M fluid tube to S-600 and put the filter into the tank. Please do not bend the fluid tube and fill the fluid tank with Antari snow fluid.



5M Fluid Tube with Filter



- Step 3.** Connect the machine to a suitably rated power supply. To determine the power requirement for the machine, refer to the label on the back of the machine.
- Step 4.** Turn on the machine, press the [VOLUME]/[DOWN] button on the control panel to start making snow. To stop making snow, press the [STOP] / [■] button
- Step 5.** To turn off the machine, press the [STOP] / [■] button and put the power switch to the OFF position.

※ Notice :

The motor of S-600 continues running for about 5 seconds after [STOP] / [■] button is pressed. Please turn off the main power after motor stops running.

8. Operation

S-600 Yeti snow machine can be operated in the following modes. The machine can accept 1 kind of signal at 1 time. When using different control modes at the same time, the machine will work according to built-in control priority.

- Manual: operation via control panel
- Timer: operation via control panel
- DMX 512
- SC-4 Wired Remote (Optional)
- Wireless DMX (Optional)
- W-2 Wireless Transmitter

Priority: Wireless DMX (Optional) > DMX512 > W-2 Wireless Transmitter > SC-4 Wired Remote (Optional) > Manual

Please see the following pages for instructions on your choice of operation.

8.1 Control Panel Operation

The machine can be operated in manual or timer modes with the onboard digital control interface

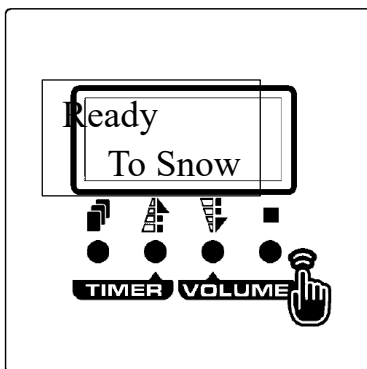

Button	Function
[MENU]	Scroll through setting menu
▲ [UP]/[TIMER]	Increase setting value/Activate Timer function
▼ [DOWN]/[VOLUME]	Decrease setting value/Activate Volume function
■ [STOP]	Deactivate Timer/Volume function Confirm/Leave Setting Menu

8.2 Control Menu

Menu	Item	Description
DMX	DMX512 Add: XXX	DMX-512 Address: 1-510 (S-600 occupies 3 control channels.)
	LinkMode	Link Mode : Wired / Wireless

	Wired		
	W-DMX Unlink?	W-DMX Linking : Linking cancelled	
Manual	Interval XXX min	Set interval time at timer mode from 5 to 240 minutes	
	Duration XXX min	Set duration time at timer mode from 5 to 240 minutes	
	Volume Out XXX%	Set output volume at volume mode from 0 to 100%	
	Blower XXX%	Set blower output from 0 to 100% to adjust snowflake size. The smaller output, the bigger snowflake.	
	Fan Speed XXX%	Set fan speed from 0 to 100%	
Info	W-DMX ---	W-DMX ok	W-DMX Transmitter assigned, DMX signal received.
		No DMX	W-DMX transmitter assigned, No DMX signal
		TX Lost	W-DMX link lost or linking to transmitter
		Unassign	W-DMX Transmitter not assigned
	UID 1ED8 06020001	Product UID Code	
	Run Time 0000000H	Accumulated Snowing time : 0 - 9999999 hour	
Setting	W.Remote Pair	Wireless Transmitter : Pair / Unpair	
	Run Last Set Off	Run the last setting : On / Off	
	KeySound Set On	Keypad Sound : On / Off	
	Backlite AlwaysOn	Screen Backlite: On /Off / AlwaysOn	
	Default Proceed?	Reset to factory settings	

9. Machine Status Message

Screen	Description
S-600	Software Version

v1.0	
AC Input AC-XXX	Input Voltage
Ready To Snow	Machine is ready to make snow.
Remote Out XXX%	SC-4 wired remote operating (only shows when SC-4 is connected)
Volume Out XXX%	Running at volume mode
Interval XXX min	Running at timer mode, Interval time
Duration XXX min	Running at timer mode, Duration time
DMX-512 Add: XXX	Current DMX 512 channel
Priming 100%	Activate pump at maximum output
Wrong Voltage!	Wrong input voltage

10. DMX Connection

10.1 DMX Connector Pin Assignment

The machine provides a 5-pin XLR connector for DMX connection. The diagram below indicates pin assignment information.



5 Pin XLR

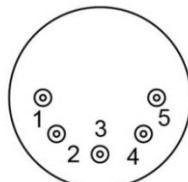

Pin	Function
1	Ground
2	Data-
3	Data+
4	N/A
5	N/A

10.2 DMX Channel Function

Channel	Mode	DMX Value	Function
Channel 1	Snow Output Volume	0-5	Snow off
		6-255	Snow Output 0-100%
Channel 2	Blower Output	0-5	Blower off
		6-255	Blower Output 0-100%
Channel 3	Fan Output	0-5	Fan Off
		6-255	Fan Output 0-100%

11. RDM

The S-600 snow machine Yeti is RDM enabled, allowing control system to configure, monitor and manage. See below table for supported RDM parameters.

GET Allowed	SET Allowed	Category	RDM Parameter ID's (Slot 21-22)	Value	Required
		Network Management	DISC_UNIQUE_BRANCH	0x0001	O
			DISC_MUTE	0x0002	O
			DISC_UN_MUTE	0x0003	O
O		RDM Information	QUEUED_MESSAGE	0x0020	
O			SUPPORTED_PARAMETERS	0x0050	O
O			PARAMETER_DESCRIPTION	0x0051	O
O		Product Information	DEVICE_INFO	0x0060	O
O			PRODUCT_DETAIL_ID_LIST	0x0070	
O			DEVICE_MODEL_DESCRIPTION	0x0080	
O			MANUFACTURER_LABEL	0x0081	
O	O		DEVICE_LABEL	0x0082	
O			SOFTWARE_VERSION_LABEL	0x00C0	O
O	O	DMX512 Setup	DMX_PERSONALITY	0x00E0	
O			DMX_PERSONALITY_DESCRIPTION	0x00E1	
O	O		DMX_START_ADDRESS	0x00F0	O

O			SLOT_INFO	(0x0120)	
O			SLOT_DESCRIPTION	(0x0121)	
O			DEFAULT_SLOT_VALUE	(0x0122)	
O		Sensors	SENSOR_DEFINITION	0x0200	
O	O		SENSOR_VALUE	0x0201	
O			DEVICE_HOURS	0x0400	O
O	O	Control	IDENTIFY_DEVICE	0x1000	O

12. Wireless Control Operation

S-600 is equipped with W-2 wireless control function as a standard. Receiver attached onto S-600 before shipped from factory.

12.1 W-2 Wireless Transmitter

- Battery : 27A 12V
- Effective distance : In a free open space, the effective distance is about 50 meters, actual usage depends on obstacle level; the effective distance varies.
- W-2 Wireless remote control system equipped with 4 buttons to activate, deactivate, adjust snow, motor and fan output level.

Button	Function
[A]	Press Once : activate output Keep pressing for 2 seconds : turn off S-600
[B]	Adjust snow output level



W-2 Wireless Transmitter



W-2 Wireless Receiver

	Range: 0/20/40/60/80/100%
[C]	Adjust motor output level Range: 0/20/40/60/80/100%
[D]	Adjust fan output level Range: 0/20/40/60/80/100%

(attached onto machine as a standard)

12.2 W-2 Wireless Receiver

S-600 is equipped with W-2 wireless control function as a standard. Transmitter is included in package. Receiver attached onto S-600 before shipped from factory.

12.3 Registering a Transmitter

- Transmitter can be paired or deleted from the receiver.
- Each receiver can pair up to 5 transmitters.
- Follow below steps to pair or delete transmitter.

Step 1. Press [MENU] button and select [Setting]. Scroll the menu until [W.Remote] shows on display.

UP: Pair
DOWN:Unpair

Step 2A. Press [UP / ▲] button to select [Pair] to pair a new transmitter. Press [STOP / ■] button, and press any button on the W-2 transmitter to finish pairing.

Step 2B. Press [DOWN / ▼] button to select [Unpair] to delete an existing transmitter.

13. Wireless DMX Operation (Optional)

13.1 WTR-90 (Optional)

WTR-90 includes a 2 in 1 (W-DMX & W-2) receiver and a W-DMX-PCB.



2 in 1 receiver (W-DMXW2R) & W-DMX-PCB

13.2 Installation Steps

Step 1. Release unscrew the receiver, and replace it by the 2 in 1 receiver (W-DMXW2R). Connect it to the cable shown as below photo and then screw it the panel.



Step 2. Connect the receiver's cable with W-DMX-PCB and then install the W-DMX-PCB onto the main PCB circled in red below.

※ Please make sure the W-DMX-PCB pins are firmly installed attached with S-600 main PCB.

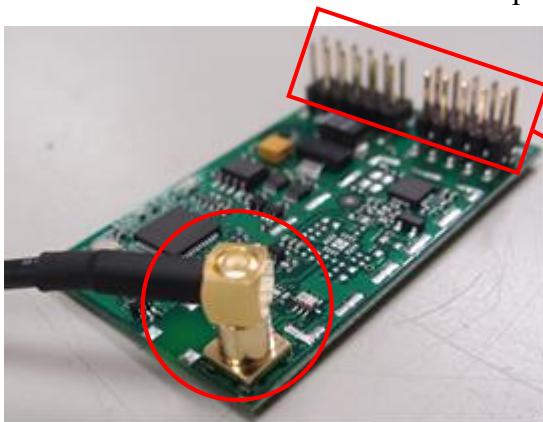

14. SC-4 Wired Remote Operation (Optional)

Wired remote control SC-4 enables to control the machine from a remote location. With three push buttons and 3 rotary knobs to activate/deactivate, priming and snow, motor and fan output level adjustment.

Button/Knob	Function
[SNOW VOLUME] Knob	Adjust snow output level 0-100%
[BLOWER SPEED] Knob	Adjust motor output level 0-100% to adjust snowflake size.
[FAN SPEED] Knob	Adjust fan output level 0-100%
[TIMER] Button	Activate Timer Setting Interval and duration time is set on control panel. Output level is controlled by rotary knob on SC-4.
[POWER] Button	Turn On/Off SC-4 remote
[MANUAL] Button	Max snow, motor and fan output level.

※IMPORTANT NOTE:

1. Press [POWER] button to activate SC-4 remote.
2. With first time operation, a new tank of fluid or refill the fluid may not pump properly due to airlock in the pipeline, use [MANUAL] button to activate pump, motor and fan at maximum output to push the air out of the pipeline.



SC-4 Connector



SC-4 Wired Remote

15. S-600-BH / 5-liter bottle holder (Optional)

Optional S-600-BH / 5-liter bottle holder is available to meet the needs of different occasions. Follow below steps to install the bottle holder.



Step 1. Release the T shaped handle on S-600.

Step 2. Install S-600-BH to the machine.

Step 3. Screw the T shaped handle back to S-600 tightly to complete the installation.

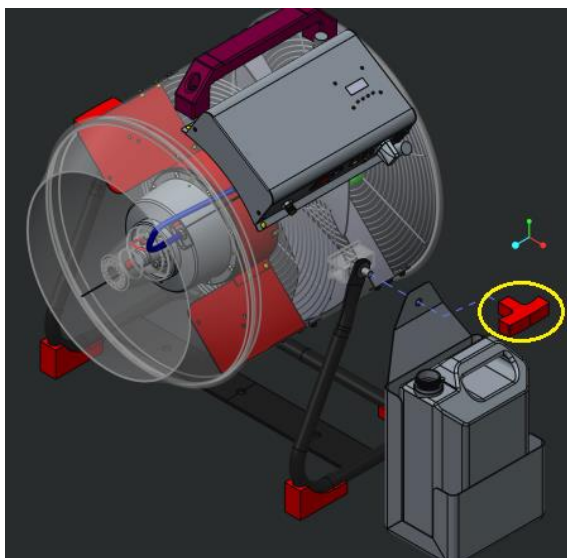

16. Service and Maintenance



DANGER!

Disconnect from mains before starting maintenance operation!

- Do not allow the machine to become contaminated.
- Remove dust from air vents with air compressor, vacuum or a soft brush.
- Only use a damp cloth to clean the casing.
- It is recommended to run the machine on a monthly basis in order to achieve best performance and output condition.
- Excessive dust, liquid and dirt built up will degrade performance and cause overheating.
- Before storing away after operation, pump pure water through the system for at least 1 to 2 minutes. This will help clean out the remaining snow fluid and prevent pump from malfunction on next usage.

17. Technical Specifications

S-600	
Input voltage	US model : AC 100-120V, 50/60Hz 10A EU model : AC 220-240V, 50/60Hz 5A
Rated power	1200W
Fluid consumption	400 ml/min
Compatible fluid	Antari SL-N Snow Foam Fluid Antari SL-AN Premium Snow Foam Fluid Antari SL-H Super Dry Snow Foam Fluid Antari SL-C Anti-Freezing Snow Foam Fluid Antari SL-UV UV Snow Foam Fluid
Ambient temp/ range	5°C – 40°C (41°F – 104°F)
Control	Manual, Timer, DMX 512, Wireless Wireless DMX (Optional)
DMX channels	3 channels
Connection	Neutrik Powercon (Power) XLR 5-pin (DMX)
Included accessories	W-2 Wireless Radio Transmitter 5-Meter Fluid Tube with Filter Hanging Bracket

Optional accessories	WTR-90 Wireless DMX SC-4 Cable Remote S-600-BH Bottle Holder (For 5-Liter Bottle. Bottle is not included)
Dimension	L 461.2 W 596 H 629.6 mm (L 18.16 W 23.47 H 24.79 inch)
Weight	24 kg (52.9 lbs)

18. Machine Dimension



19. Exploded diagram

19.1 AC-120V

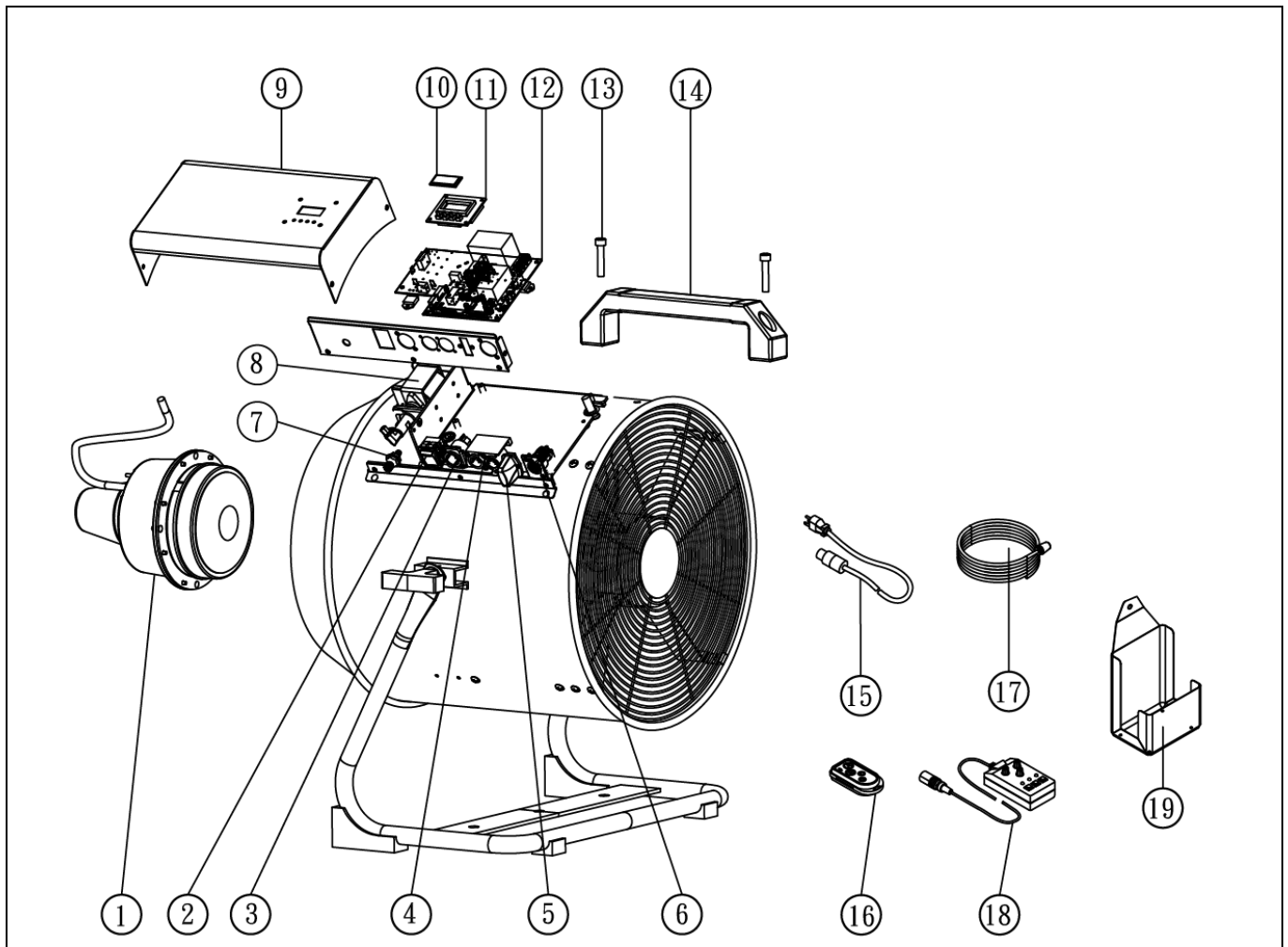

SPARE PARTS OF S-600

1	S-600-M	Air blower	11	S-600-PCBC	Control P.C board
2	C040039B0	Rocker switch / Power	12	S-600-PCB	Main P.C board
3	C04312621	Power socket (Inlet)	13	C01007010	Socket head cap screw
4	S-600-PCBD5	P.C board DMX 5Pin	14	C02025000	Handle
5	W-2A	Wireless transmitter	15	S-600-PC	Power cord & Plug
6	C045E2900	Control inlet socket	16	W-2RA	Wireless Receiver
7	C00013610	Fluid tube connector	17	FT-P-6-4A-5M	Fluid tube with filter / 5M
8	S-600-P	Pump (Group)	18	SC-4	Wired remote controller (Optional)
9	S60000100	Steel	19	S-600-BH	Bottle holder (Optional)
10	C02000700	Acrylic			

19.2 AC-230V

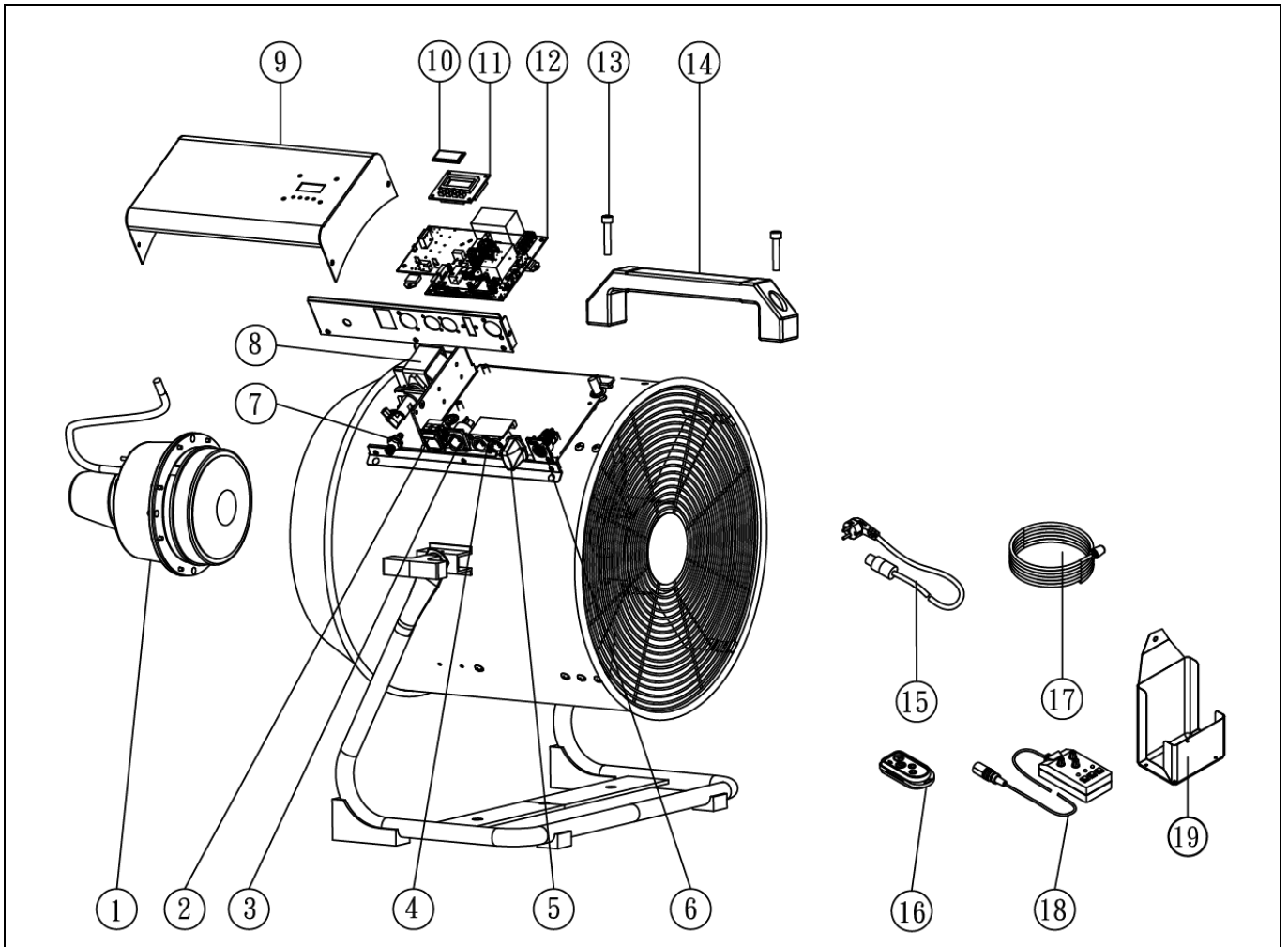

SPARE PARTS OF S-600

1	S-600E-M	Air blower	11	S-600-PCBC	Control P.C board
2	C040039A0	Rocker switch / Power	12	S-600-PCB	Main P.C board
3	C04312621	Power socket (Inlet)	13	C01007010	Socket head cap screw
4	S-600-PCBD5	P.C board DMX 5Pin	14	C02025000	Handle
5	W-2E	Wireless transmitter	15	S-600-PC	Power cord & Plug
6	C045E2900	Control inlet socket	16	W-2RE	Wireless Receiver
7	C00013610	Fluid tube connector	17	FT-P-6-4A-5M	Fluid tube with filter / 5M
8	S-600-P	Pump (Group)	18	SC-4	Wired remote controller (Optional)
9	S60000100	Steel	19	S-600-BH	Bottle holder (Optional)
10	C02000700	Acrylic			



SNOW MACHINE
S-600 Yeti



C08S6000