



M-11

Stage Fog Machine

User Manual

- ENGLISH



M-11

STAGE FOGGER



© 2020 Antari Lighting and Effects Ltd.

M-11

STAGE FOGGER

Safety Information



Please read the following safety information carefully before operating the machine. This information includes important safeguards about installation, usage, and maintenance. Pay attention to all warning labels and instructions in this manual and printed on the machine.

If you have questions about how to operate the machine safely, please contact your local Antari dealer for help.

- Keep this device dry.
- Always connect to a grounded circuit to avoid risk of electrocution.
- Before connecting the machine to power, always check the voltage indicated on the machine matches to your local AC voltage. Do not use the machine if AC power voltage does not match.
- Disconnect the machine from AC power before servicing and when not in use.
- If the supply cord is damaged, contact your local Antari dealer for replacement.
- This product is for indoor use only! Do not expose to rain or moisture. If fluid is spilled, disconnect AC power and clean with a damp cloth. If fluid is spilled onto electronic parts, immediately unplug the machine and contact your local Antari dealer for advice.
- No user serviceable and modifiable parts inside. Never try to repair this product, an unauthorized technician may lead the machine to damage or malfunction.
- For adult use only. Children being supervised not to play with the machine. Never leave the machine running unattended.
- The machine is not to be used by persons (including children) with reduced physical, sensory or mental capabilities, or lack of experience and knowledge.
- Installed in a well ventilated area. Provide at least 50 cm space around the machine.
- Never add flammable liquid of any kind to the machine.
- Make sure there are no flammable materials close to the machine while operating.
- Only use Antari fluid. Other fluid may lead to heater clog and malfunction.
- If the machine fails to work, unplug the machine and stop operation immediately. Contact your local Antari dealer for .
- Before transporting the machine, make sure the fluid tank is completely drained.

- Smoke fluid may present health risks if swallowed. Do not drink smoke fluid. Store it securely. In case of eye contact or if fluid is swallowed immediately look for medical advice.

Unpacking and Inspection

Immediately upon receiving the machine, carefully unpack the carton, check the content to ensure that all parts are present and have been received in good condition. If any parts appear damaged or mishandled from shipping, notify the shipper immediately and retain the packing material for inspection.

What is included:

- 1 x M-11 Stage Fogger
- 1 x Power Cord
- 1 x User Manual

Product Dimensions



Product Overview

Wireless Receiver (W-2 Wireless Remote)

XLR 3-Pin DMX Connector

XLR 5-Pin DMX Connector

Neutrik TRUE 1 Power

Two rotary knobs (Timer / Volume)



Setting Up

Step 1: Place the machine on a flat surface and in a suitably large area with at least 50 cm of open space around the machine.

Step 2: Fill the fluid tank with Antari approved fluid.

Step 3: Connect the machine to a suitably rated power supply. To determine the power requirement for the machine refer to the label on the back of the machine.



Always connect the machine to a protected circuit and ensure it is properly grounded to avoid risk of electrocution.

Step 4: Turn on the machine and allow it to heat up. Heat up takes approximately 13 minutes. Once the machine has reached operating temperature, the LCD display will show “Ready To Fog”. Now the machine is ready for operation.

Step 5: To start making fog, locate the rotary knob on the right side of control panel, and press the rotary knob to start making fog.

Step 6: To turn off the machine, press rotary knob again button and turn Powercon to the **OFF** position.

Operation

Control Panel Operation

The machine can be operated with the onboard digital control interface.

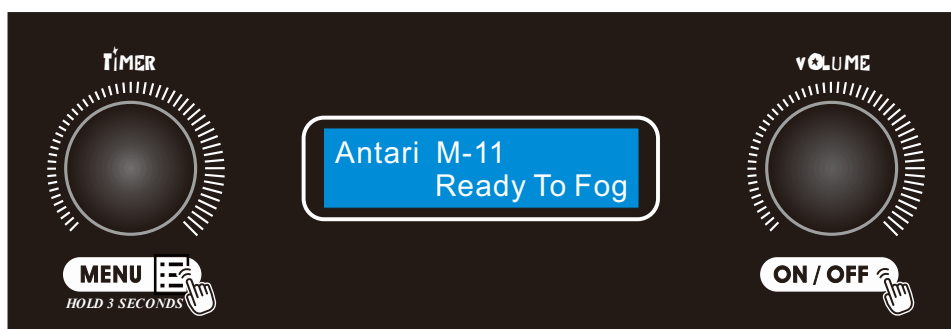

Operation - Timer Mode

Rotary knob	Action	Description
Left	Press once	Activate timer mode
Right	Press second time	Deactivate timer mode
Right	Rotate	Adjust output volume

Operation – Volume Mode

Rotary knob	Action	Description
Right	Press once	Activate volume mode
Right	Press second time	Deactivate volume mode
Right	Rotate	Adjust output volume

Setting

Rotary knob	Action	Description
Left	Press and hold for 3 seconds	Enter setting menu
Left	Rotate	Scroll through menus
Left	Press	Press once to enter
Left	Rotate	Adjust for preferred value
Right	Press	Escape from menu

Control Menu

Main Menu	Level 1	Level 2
DMX	Address	001-512
	Channel Mode	1/3
	Link Mode	Wired/Wireless
	W-DMX	Unlink
Timer	Interval	5 – 200 sec
	Duration	1 – 200 sec
	Output Level	0 – 100%
Manual	Output Level	0 – 100%
	Priming	Start/Stop
	Heater	On/Off
Information	Software Version	VX.X
	Wireless Signal	●: W-DMX present

		◎: No DMX present ◐: Link to TX lost ○: Not assigned
	Fluid Level	Fine/Empty
	Device Hour	XX Hour
Setting	Continuous Output	On/Off
	Pump Mode	Single/Dual
	Wireless Remote	Pair/Unpair
	Fluid Sensor	On/Off
	LCD Backlight	Auto Off/Low/Normal
	Keypad Sound	On/Off
	Auto Start	On/Off
	Factory Reset	Proceed
	Language	EN/ZH
	Fluid Option	FLG/FLY/FLZ/FLR

DMX Connector Pin Assignment

The machine provides both 3 and 5-pin XLR connector for DMX connection. The diagram below indicates pin assignment information.

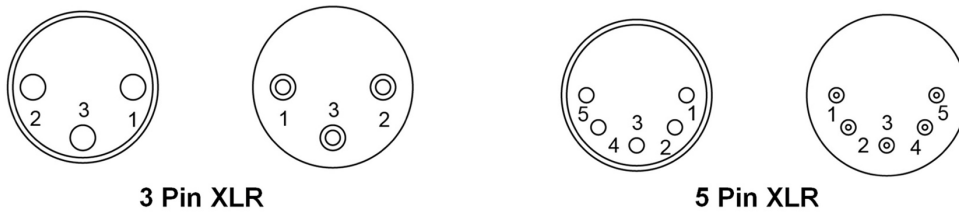

Pin	Function
1	Ground
2	Data-
3	Data+
4	N/A
5	N/A

DMX Operation

Making the DMX Connection – Connect the machine to a DMX controller or to one of the machines in the DMX chain. The machine uses both 3-pin and 5-pin XLR connector for DMX connection, the connector is located on the rear of the machine.

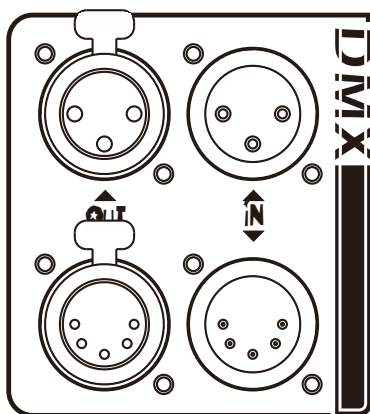

DMX Channel Function

1 Channel Mode	DMX Value Range	Function
Output Level	0 – 4	Off
	5 – 255	1 – 100%
3 Channel Mode	DMX Value Range	Function
Output Level	0 – 4	Off
	5-255	1 – 100%
Heater	0-126	Off
	127-255	On
Pump	0 – 126	Single
	127-255	Dual

RDM Control

The M-11 Stage Fogger is RDM enabled, allowing control system to configure, mointonr and manage. See below table for supported RDM parameters

Value	RDM Parameter ID's	GET Allowed	SET Allowed
0x0001	DISC_UNIQUE_BRANCH		
0x0002	DISC_MUTE		
0x0003	DISC_UN_MUTE		
0x0030	STATUS_MESSAGE	0	
0x0050	SUPPORTED_PARAMETERS	0	
0x0051	PARAMETER_DESCRIPTION	0	
0x0060	DEVICE_INFO	0	
0x0070	PRODUCT_DETAIL_ID_LIST	0	

0x0080	DEVICE_MODEL_DESCRIPTION	O	
0x0081	MANUFACTURER_LABEL	O	
0x0082	DEVICE_LABEL	O	O
0x00A0	LANGUAGE_CAPABILITIES	O	
0x00B0	LANGUAGE	O	O
0x00C0	SOFTWARE_VERSION_LABEL	O	
0x00E0	DMX_PERSONALITY	O	O
0x00E1	DMX_PERSONALITY_DESCRIPTION	O	
0x00F0	DMX_START_ADDRESS	O	O
0x0200	SENSOR_DEFINITION	O	
0x0201	SENSOR_VALUE	O	
0x0400	DEVICE_HOURS	O	
0x1000	IDENTIFY_DEVICE	O	O

Wireless Operation

Wireless remote control system W-2 consists of a transmitter equipped with four buttons to activate, deactivate, increase and decrease fog output and an onboard receiver attached to the rear panel of M-11 fog machine.



W-2 Wireless Transmitter

Press [A] button to emit fog. Press [B] button to stop. Press [C] button to increase output volume. Press [D] button to decrease output volume.

In an unobstructed open space the effective distance is 50 meters, usage depending on obstacle level the effective distance is 10-25 meters.



Wireless Receiver

Registering a transmitter

Transmitters can be paired or deleted from the receiver. Each receiver can pair up to 5 transmitters. Follow the steps below to pair or delete a transmitter from a receiver.

Step 1: Press and hold the left rotary knob for 3 seconds to enter setting menu.

Step 2: Rotate the rotary knob to find the “Wireless Detect” menu.

Step 3: Follow the menu instruction to pair or delete a transmitter.

Transmitter battery replacement

If the effective distance seems to decrease, it is possible the battery level is low and requires replacement. In order to replace the battery, undo the three screws on the back of transmitter to release the cover. Replace with the same type and specification of battery which is 27A 12V

Status of W-DMX Connection (Optional)

Symbol on the Liquid Crystal Display	Status of W-DMX connection
○	Transmitter not assigned
⊙	Transmitter assigned, No DMX signal
◉	Transmitter link lost or linking to transmitter
●	Transmitter assigned, DMX signal received

Fluid



Only use Antari FLR/FLG water-based liquid for the M-11 Stage Fogger. The machine is tested and calibrated with this liquid to get the best output performance. Warranty will be voided if any other type of liquid is used, improper use of liquid may lead to machine failure and malfunction.

Service and Maintenance

- Do not allow the machine to become contaminated.
- Remove dust from air vents with air compressor, vacuum or a soft brush.
- Only use a damp cloth to clean the casing.
- Before storing run distilled water through the system to help prevent condensing the pump or heater.

- It is recommended to run the machine on a monthly basis in order to achieve best performance and output condition.
- Excessive dust, liquid and dirt built up will degrade performance and cause overheating.

Breaker Reset



Disconnect AC power before resetting the breaker. Only replace fuse with same type and rating.

Step 1: Disconnect AC power.

Step 2: Flip breaker to ON position.

Step 3: Turn on machine for testing.

Breaker

100-120V = 15A 250V

220-240V = 7A 250V

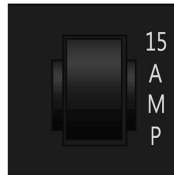

Technical Specifications

- Input voltage	US model : AC 100-120V, 50 / 60Hz 13.3A EU model : AC 220-240V, 50 / 60Hz 6.67A
- Rated power	1600 W
- Warm-up time	13 minutes (approx)
- Fluid consumption	400 ml / min (100% output)
- Fluid tank capacity	10 Liters
- Compatible fluid	Antari FLG 10 Heavy Fog Fluid Antari FLR 10 Light Fog Fluid
- Ambient temp/ range	0°C - 40°C (32°F-104°F)
- Control	DMX 512, Timer, Manual, Wireless (Optional) Wireless DMX (Optional)
- DMX channels	1 or 3 channels
- Connection	Neutrik TRUE1 Connector (Power) XLR 3-pin and XLR 5-pin (DMX), W-DMX-PCBR Wireless DMX
- Optional accessories	WTR-20 Wireless WTR-70 Wireless DMX and Remote
- Dimension	L 674.5 W 319.8 H 284.3 mm
- Weight	25 kg (55.1 lbs)

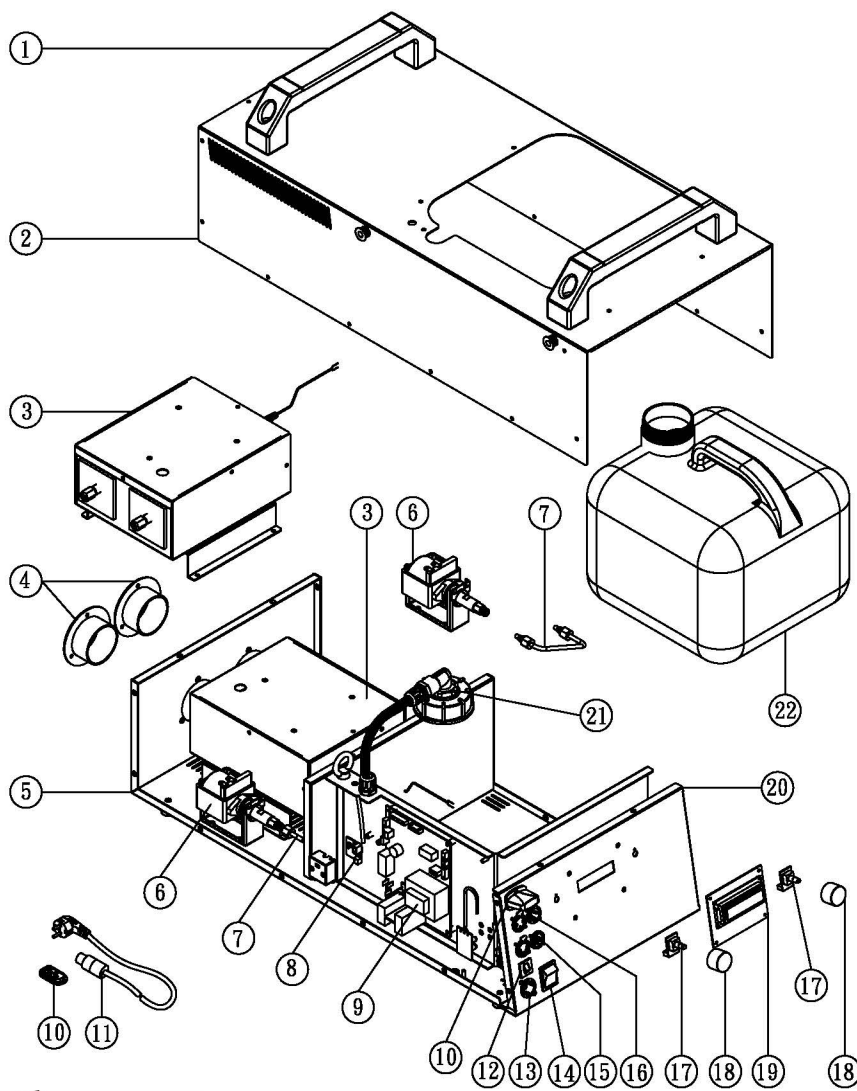

M-11

STAGE FOGGER

- | | | | | | |
|-------------|------------------------|-------------|---------------------|--------------|--------------------|
| ① M-11-HL | Handle | ⑩ WTR-20E | Wireless (Optional) | ①⑥ DMX3P00AB | P.C Board DMX 3Pin |
| ② M01100H00 | Steel Case | ⑪ PCE015204 | Power Cord & Plug | ①⑦ B06721A00 | Variable Resistor |
| ③ M-11E-H | Heater (Group) | ⑫ C04102100 | Breaker | ①⑧ C04006500 | Control Knob |
| ④ C02006000 | Plastic Nozzle | ⑬ C04312610 | Power Inlet | ①⑨ M-11-PCBC | LCD |
| ⑤ M0110LL00 | Steel Case | ⑭ C04000100 | Rocker Switch/Power | ②① M01100L00 | Steel Case |
| ⑥ PE0EX5A30 | Pump (Group) | ⑮ DMX5P00A5 | P.C Board DMX 5Pin | ②② TK0210000 | Tank Cap (Group) |
| ⑦ M-11-CP | Brass Tube | | | | Tank |
| ⑧ M-11-PCBS | Optical liquid Sensing | | | | |
| ⑨ M-11E-PCB | Main P.C Board | | | | |

Antari[®]
FOG MACHINE

M-11
STAGE FOGGER



C08M11001